



QUALITY  
THE QUALITY FACTOR  
BPW · THE QUALITY FACTOR  
THE QUALITY FACTOR  
FACTORY

## New Components for ECO Drum

BPW has made detail changes to the cover plate of the ECO Drum drum braked axles.

Henceforth, only the new style brake drums and the new cover plates will be supplied in exchange.

All the new components are however fully interchangeable with the previous ones and the brake drums can also be used on the previous drum brake axles without exchanging the cover plates.

However, when switching to the new brake drums, BPW also recommends that the new cover plates be used to ensure optimum sealing.

**ECO Drum - Previous version**

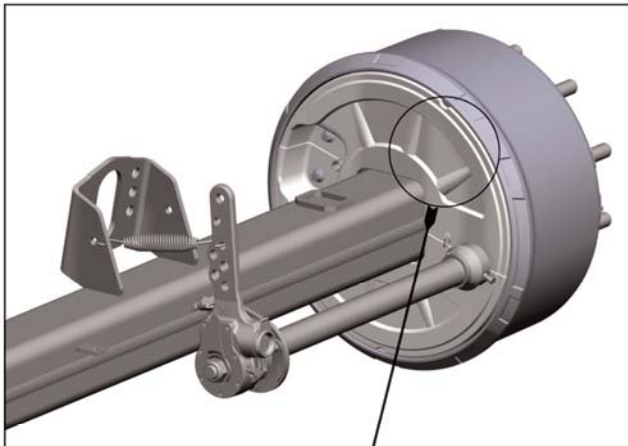

**ECO Drum - New version**

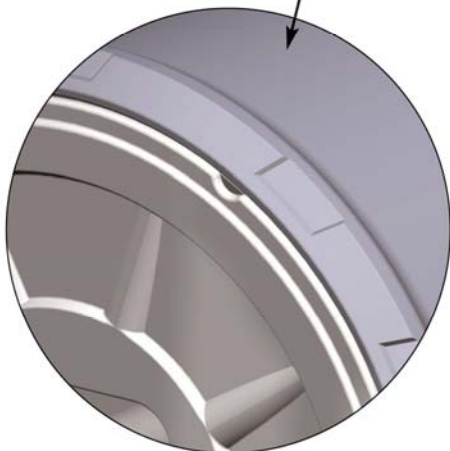
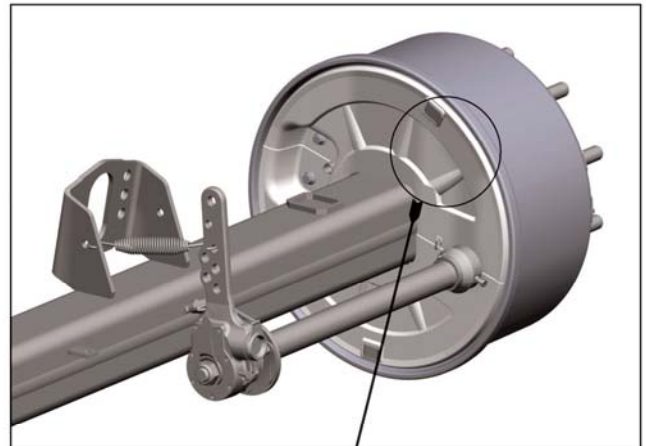



# BPW · THE QUALITY FACTOR



Below is a summary of the old and new part numbers

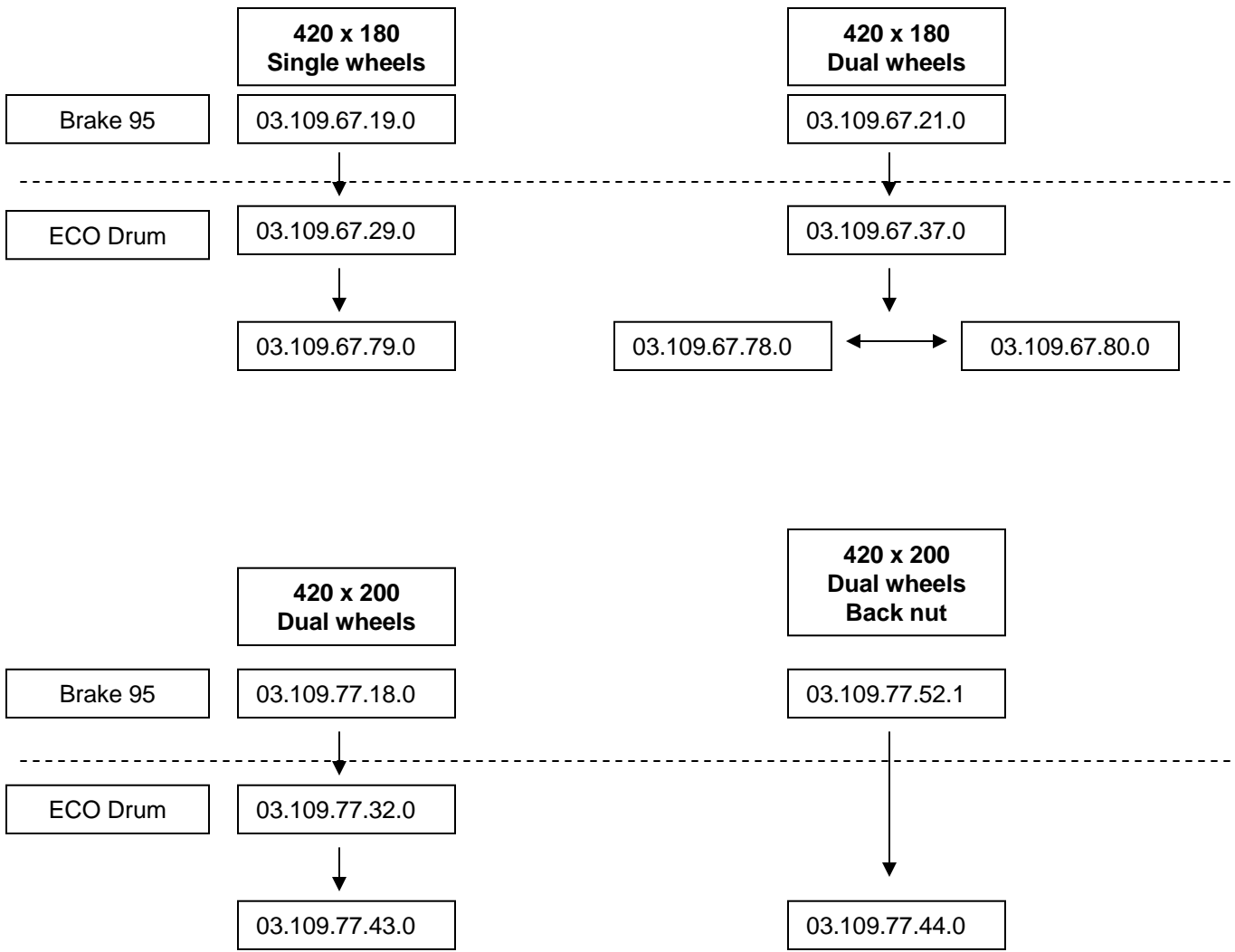



# BPW · THE QUALITY FACTOR



Below is a summary of the old and new part numbers

## Cover plate assemblies

	420 x 180	420 x 200
Brake 95	99.00.000.0.93	99.00.000.0.98

The cover plate assemblies are still available for Brake 95 axles – (ECO AND ECO<sup>Plus</sup>)

---

ECO Drum	99.00.000.1.12	99.00.000.1.15
	↓	↓
	99.00.000.1.23	99.00.000.1.26

The cover plate assemblies .12 and .15 are still available for spare parts and will be replaced with .23 and .26 once stock has run out.