

BPW Air bag Quality

The basic construction of a BPW Air bag is shown in Figure 1. There are four distinct BPW Air bag sizes used in South Africa, namely the:

- BPW 30K
- BPW 30
- BPW 36K
- BPW 36

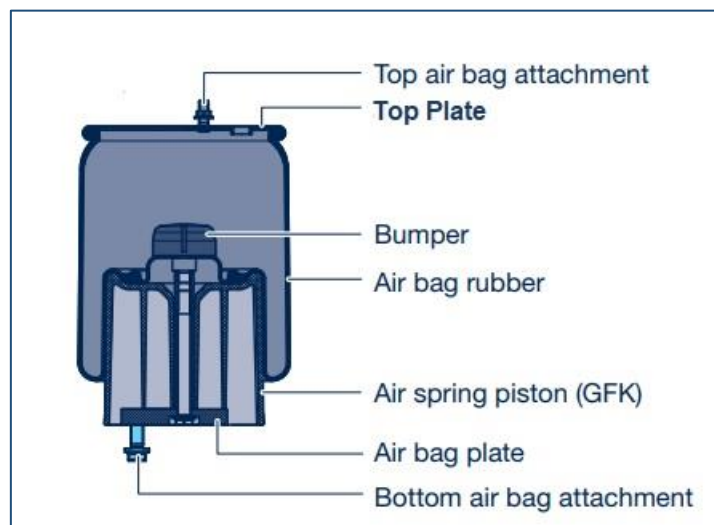

Figure 1: Airbag Layout

The number indicates the Air bag diameter, i.e. 30 is a $\text{Ø}300\text{mm}$ while 36 is $\text{Ø}360\text{mm}$. The K indicates a shorter stroke of 180mm. Without a “K”, the stroke is 200mm.

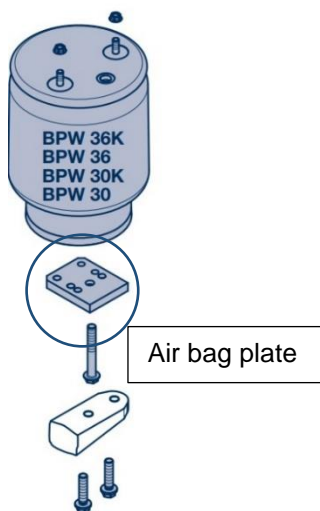

Figure 2 – Air bag mounting

Figure 2 shows that the Air bag gets fastened to the trailing arm with two bolts and by means of a universal steel plate which is inserted into the base of the Air bag piston with possible offsets of $V = 0 / 20 / 60\text{mm}$ for the BPW 30 & 30K Air bags and $V = 45 / 80\text{mm}$ for the BPW 36 & 36K Air bags.

The Air bag

The wall thickness of an Air bag is typically 4.3 mm to 4.5 mm thick and is designed to achieve an optimum coverage of performance aspects – mechanical endurance of rubber material and rubber / fabric adhesion, temperature resistance, bellow rolling flexibility in low pressure conditions, air tightness, etc.

The rubber used in an Air bag bellow is made up of four different layers:

1. An inner liner – which performs the sealing function.
2. Fabric layers (plies) – to keep the shape constant and carry the load forces.
3. A rubber matrix – to join the reinforcement material and separate the layers of fabric plies.
4. An outer liner – to protect the airbag from friction (mechanical) and chemical (environment) factors.

Due to the natural gas permeability of the rubber components, air is known to diffuse through the walls of an Air bag bellow – even when new, see Figure 3. The higher the internal pressure the higher the rate of diffusion. Air diffusion is not related to production or material faults; it is product typical and does not indicate a technical leakage.

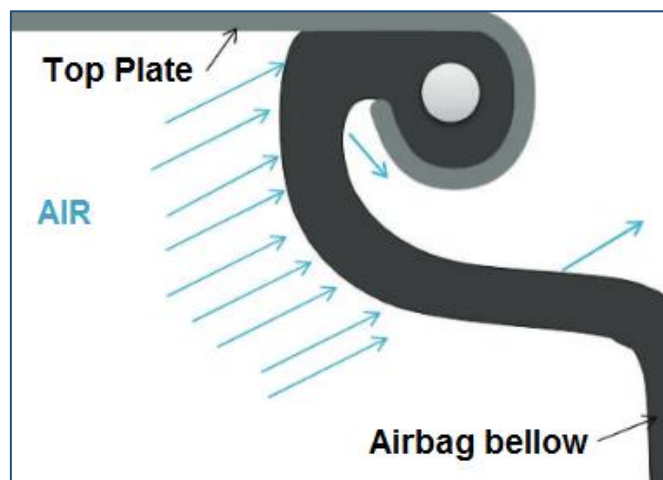

Figure 3

The Air bag plate

The Airbag plate for both the BPW 30 and 36 sized Air bags has been designed so that the Airbag can be mounted at an offset. Mounting the Air bag at an offset allows one to achieve a greater clearance between tyre and Air bag, especially when using dual wheel fitment. Having the Air bag mounted at an offset induces a bending moment in the plate and when not correctly designed this plate will bend, especially when loads are greater than the operational loads, i.e. dynamic loading such as driving over bumps.



When installing the Air bag care must be taken to install onto the correct offset. The Air bag centre at the top (on the vehicle frame) must not deviate by more than 10mm from the Air bag centre at the bottom (on the axle side), see Figure 4. The Air bag must not be installed with a twist between the top and bottom airbag attachment.

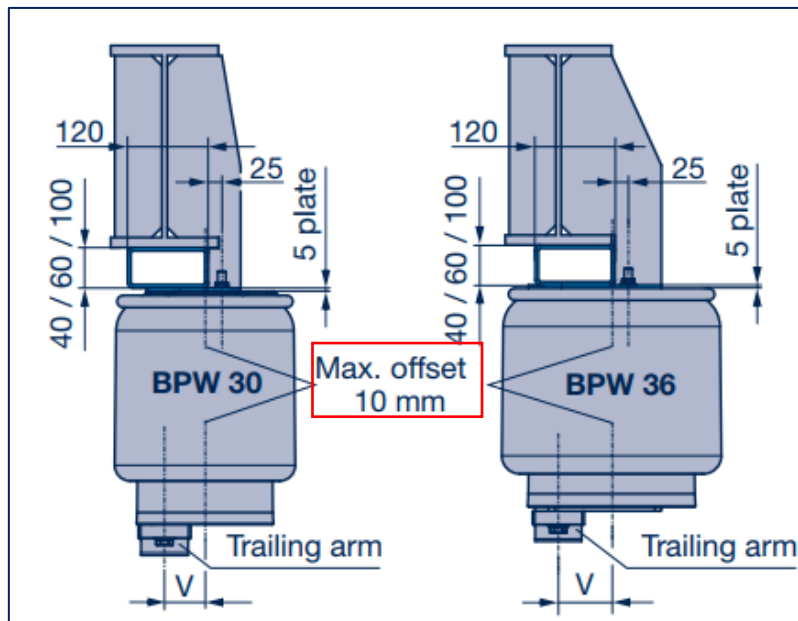

Figure 4

The top plate

When installing the air bag it is important that the two all the bolts and nuts are torqued correctly before pressurising the air bag to the operating pressure.

1. The top air bag connection consists of two M12 studs, which are welded onto the top plate, and nuts. They need to be torqued to 66 Nm.
2. The bottom air bag connection consists of two M16 bolts which need to be torqued to 230 Nm.

If the connections are not torqued correctly and are only fitted loosely failures that will occur are:

Top plate bulging, see

- 1.



Photo 1

Prolonged operation of a loose air bag will result in the area around top plate studs to crack, see Photo 1



Photo 1

The correct test procedure of BPW Airbags

1. Secure the air bag, ensuring that the top and bottom air bag connections are properly tightened.
2. Inflate the Air bag to 3.5 bar and allow to stand for 12 hours.
3. The pressure should not drop below 3 bar in that time.
4. If the Air bag pressure drops below the low point (3 bar) the Air bag needs to be replaced.

The foam leakage test (see Photo 2) is applicable for rubber products like air springs (Air bags). Small non-critical foam formation on the bellows might occur sporadically and do not indicate diffusion.

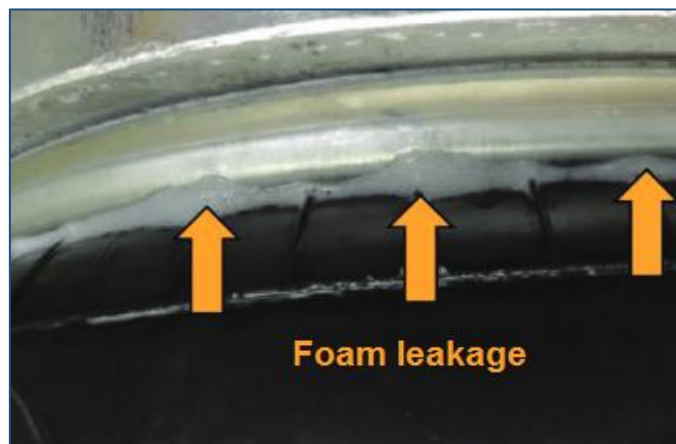

Photo 2