

SH
SKH

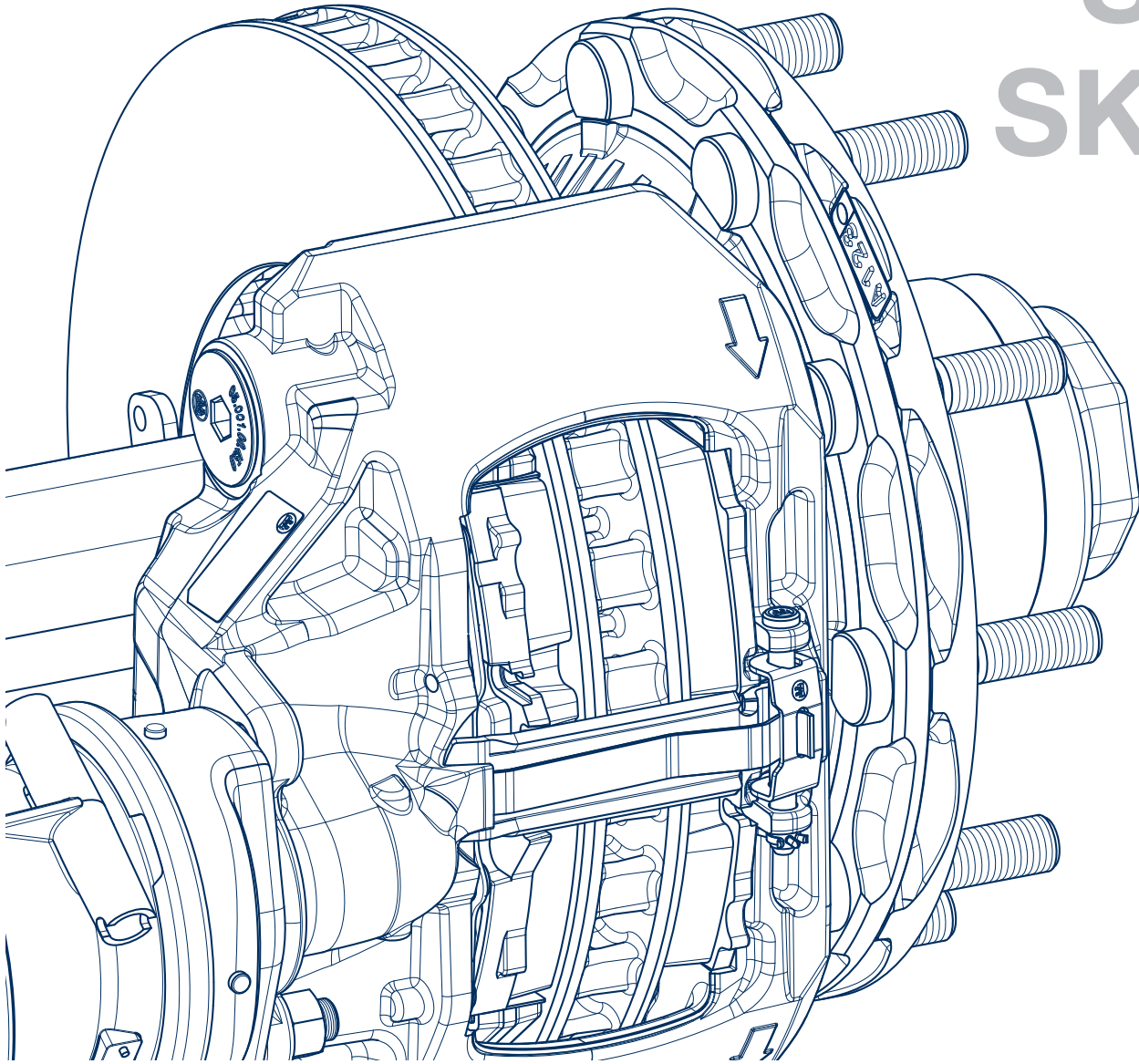

Workshop manual

BPW trailer axles
with ECO Disc TS2 trailer disc brakes



Contents

BPW trailer axles with ECO Disc TS2 trailer disc brakes TS2 3709, TS2 4309

Valid: 01/01/2023

Subject to change without notice.

Current versions and additional information can be found online at www.bpw.de.

Contents

◎ 1. Product identification	Page 4
1.1 BPW type plate - axle	Page 4
1.2 BPW axle type explanation	Page 4
1.3 BPW item number explanation	Page 5
1.4 BPW type plate - brake	Page 5
◎ 2. Safety regulations, safety information	Page 6
2.1 Safety regulations	Page 6
2.2 Safety information	Page 7
◎ 3. Exploded view / name	Page 10
◎ 4. Tightening torques	Page 13
◎ 5. Special tools	Page 14
◎ 6. Lubrication and maintenance	Page 21
◎ 7. Structure and function	Page 32
7.1 Applying the brake	Page 32
7.2 Releasing the brake	Page 32
7.3 Adjustment	Page 32
7.4 Resetting	Page 33
7.5 Brake cylinder	Page 33
◎ 8. Changing the brake linings	Page 34
8.1 Resetting the threaded sleeve	Page 34
8.2 Adjusting the clearance	Page 38
◎ 9. Brake pad wear sensing, brake lining - dust cover	Page 41
9.1 Disassembly of the brake pad wear sensing	Page 41
9.2 Assembly of the brake pad wear sensing	Page 41
9.3 Brake lining - dust cover	Page 43
◎ 10. Disassembly / assembly of the brake caliper	Page 44
10.1 Removing the brake caliper	Page 44
10.2 Installing the brake caliper	Page 45
◎ 11. Changing the bellow with pressure plate	Page 49
◎ 12. Overhauling the brake caliper guide	Page 52
12.1 Replacing the bellow (fixed and floating bearing)	Page 52
12.2 Replacing the guide bush (brass bush)	Page 53

◎ 13. Disassembly / assembly of the brake cylinders	Page 58
13.1 Diaphragm cylinder disassembly	Page 58
13.2 Diaphragm cylinder assembly	Page 58
13.3 Spring brake cylinder disassembly	Page 60
13.4 Spring brake cylinder assembly	Page 61
◎ 14. Changing the brake disc	Page 64
14.1 Changing the brake disc for axles with ECO Plus 3 Unit: TS2 3709 with ET 120 and TS2 4309 ECO Plus Unit: TS2 4309 (10 t)	Page 64
14.2 Changing the brake disc for axles with ECO Plus 3 Unit: TS2 3709 with ET 0 ECO Plus Unit: TS2 3709 (10 t)	Page 74
◎ 15. Dismantling and assembling the hub unit.....	Page 86
15.1 ECO Plus 3 Unit	Page 86
15.2 ECO ^{Plus} Unit	Page 95
◎ 16. Troubleshooting	Page 102

1 Product identification

1.1 BPW type plate - axle

The suspension components and the air spring components can be identified from the production number, the QR code or the barcode.

1.2 BPW axle type explanation (extract)

Example:										
SH	S	F	A	LL	9010	-15	ECO Plus 3			
								Series	Brake	Tyre
SH								SH..	TS2 4309	22.5"
SKH								SKH..	TS2 3709	19.5" (22.5")
SM								SM..	TS2 4309	22.5"
SKM								SKM..	TS2 3709	19.5" (22.5")
	B							For single wheels, wheels with offset		
	S							For single wheels, wheels without offset		
	Z							For twin wheels		
		F						Wheel studs M 22 x 1.5 without wheel nuts, wheel nuts for bolt or spigot alignment separate		
		M						For spigot alignment		
			A					With alloy hub		
				LL				Self-steering axle, series LL		
					8008 to 12010			Axle load in kg + quantity of wheel studs per hub		
						-15		Axle beam - wall thickness, e.g. 15 mm		
						8° to 27°		Steering angle of steering axles		
							ECO Plus 3	Trailer axle with ECO Plus 3 Unit		
							ECO ^{Plus}	Trailer axle with ECO ^{Plus} Unit		

1.3 BPW item number explanation (extract)

Example:						
20.	68.	43.	0152			
				Axle type		
20. / 27.				Trailer axle without suspension parts		
26. / 29.				Steering axle without suspension parts		
				Axle load	Roller bearings	Bearing generation
50.				10000 - 12000 kg	33118 / 33213	ECO ^{Plus} Unit
				Wheel brake	Dimension	Year of manufacture
	626.			TS2 3709	Ø 370	01/2019 ->
	627.			TS2 4309	Ø 430	01/2019 ->
				000	Consecutive number 0000 - 9999	
				Axle load	Roller bearings	Bearing generation
68.				8000 - 9000 kg	33118 / 33213	ECO Plus 3 Unit
70.				10000 - 12000 kg	33118 / 33213	ECO Plus 3 Unit
				Wheel brake	Dimension	Year of manufacture
	42.			TS2 3709	Ø 370	01/2019 ->
	43.			TS2 4309	Ø 430	01/2019 ->
				0152	Consecutive number 0000 - 9999	

1.4 BPW type plate - brake

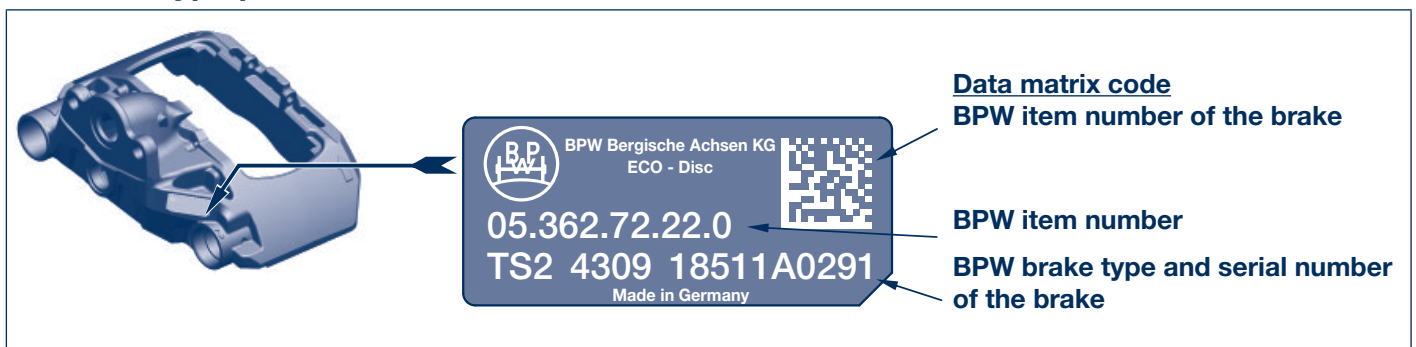

To facilitate the use of this workshop manual, we recommend that you note the key characteristics of your axle before starting repair work. See the table below for help.

Wheel hub bearing	e.g. ECO Plus 3 Unit	Identified via the 3rd and 4th digits of the axle item number on the axle type plate 50. -> ECO ^{Plus} Unit 68. / 70. -> ECO Plus 3 Unit
Brake	e.g. TS2 4309	Identified by the 5th and 6th digits in ECO Plus 3; in all other versions by the 5th to 7th digit of the axle item number on the type plate of the axle 42. / 626. -> TS2 3709 43. / 627. -> TS2 4309 or directly on the brake type plate

2 Safety regulations, safety information

2.1 Safety regulations

- All work must be performed by trained mechanics at qualified service centres and authorised specialist companies who have access to all relevant tools and have acquired the know-how required for this work. Anyone who performs maintenance and repair work must be trained in automotive mechanics and already have experience in repairing drawbar trailers and semi-trailers. Anyone who performs brake work must be trained in brake systems.
 - Comply with local safety regulations.
 - The relevant operation and service regulations as well as safety regulations of the vehicle manufacturer and of the manufacturers of other vehicle parts must be adhered to.
 - The grinding of brake linings creates very fine-grained dust that can cause lung damage. A safety mask must therefore be worn to prevent brake dust from being inhaled.
 - Use prescribed dust washing devices or vacuum cleaners for cleaning; never use compressed air or other high-pressure devices.
 - Ensure adequate ventilation at the workplace.
 - The vehicle must be prevented from moving during repair work. Please observe the relevant safety regulations for repair work on commercial vehicles, in particular the safety regulations for jacking up and securing the vehicle.
 - During repair work, make sure that the brake is not inadvertently operated. The brakes must be released.
 - Do not perform repair work unless wearing protective clothing (gloves, safety boots, safety goggles, etc.) and using the recommended tools.
 - Work on the brake outside of the vehicle must be carried out with the brake clamped in a device, such as a vice.
 - Only use recommended tools.
 - When removing the brake caliper, only touch it on the sides with your hands to avoid crushing your fingers.
 - A second mechanic must provide assistance when working with heavy components (brake discs or brake disassembly/assembly).
 - All air lines and components must be depressurised before opening.
 - Following each repair, perform a function check or a test drive in order to make sure that the brakes are functioning correctly. The braking effect of new discs and linings is only optimum after a few braking actions. Avoid hard braking.
 - All exchanged components must be reused or disposed of in accordance with the applicable environmental regulations, laws and directives.
 - The brake caliper with the clamping unit must not be opened. The fixing screws of the cover plate must not be unscrewed or released.
 - Carry out a visual inspection of the remaining brake lining thickness (see page 25) and the condition of the brake disc (see page 26) at regular intervals depending on how frequently and for what applications the vehicle is used.
 - Tighten screws and nuts with the prescribed tightening torque.
 - Only use wheels that have valves outside the wheel brace.
-

2.2 Safety information

This workshop manual contains different types of safety instructions, each of which is marked by an icon and a signal word. The signal word describes the severity of the potential danger.



Danger!
Warning!
Caution!

Immediate potential danger of serious or fatal injury (severe injury or death).
Possible potential danger of serious or fatal injury (severe injury or death).
Possible dangerous situation (slight injury or damage to property).



Repair note!

Warning of damage to property or consequential damage if this information is not observed.



Note!

Application hints and especially useful information.



Mandatory!

Do not use an impact wrench. Doing so would cause considerable damage!

It is essential that maintenance is carried out in accordance with the prescribed intervals in order to maintain the safe operation and road safety of the vehicle.

Rectification of any defects which are discovered or replacement of worn parts should be carried out by a BPW Service Centre or BPW Direct Service Partner unless the vehicle owner has the required specialist personnel, the required technical facilities and workshop manuals or possesses an official certificate to perform interim inspections or special brake inspections.

When installing spare parts, it is strongly recommended to only use original BPW components. Parts authorised by BPW for trailer axles and axle units are regularly subjected to special inspections. BPW accepts product responsibility for them.

BPW is unable to determine whether all third party products can be used with BPW trailer axles and axle units without any safety risk; this also applies even if an authorised testing organisation has accepted the product.

The warranty becomes null and void if spare parts other than original BPW parts are used in the context of warranty work.





3 Exploded view

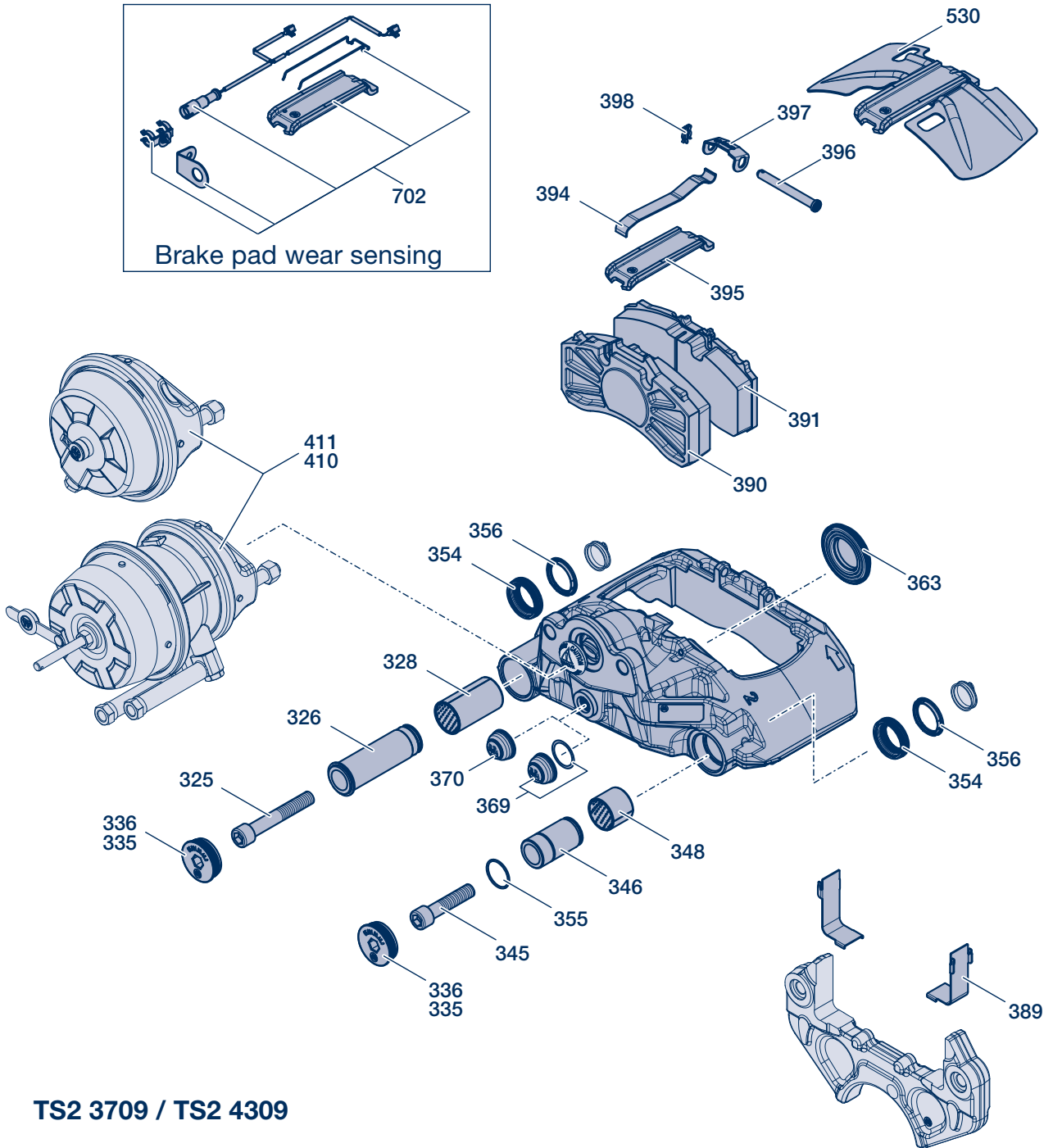
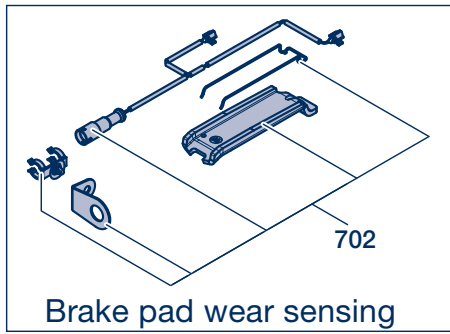

TS2 3709 / TS2 4309

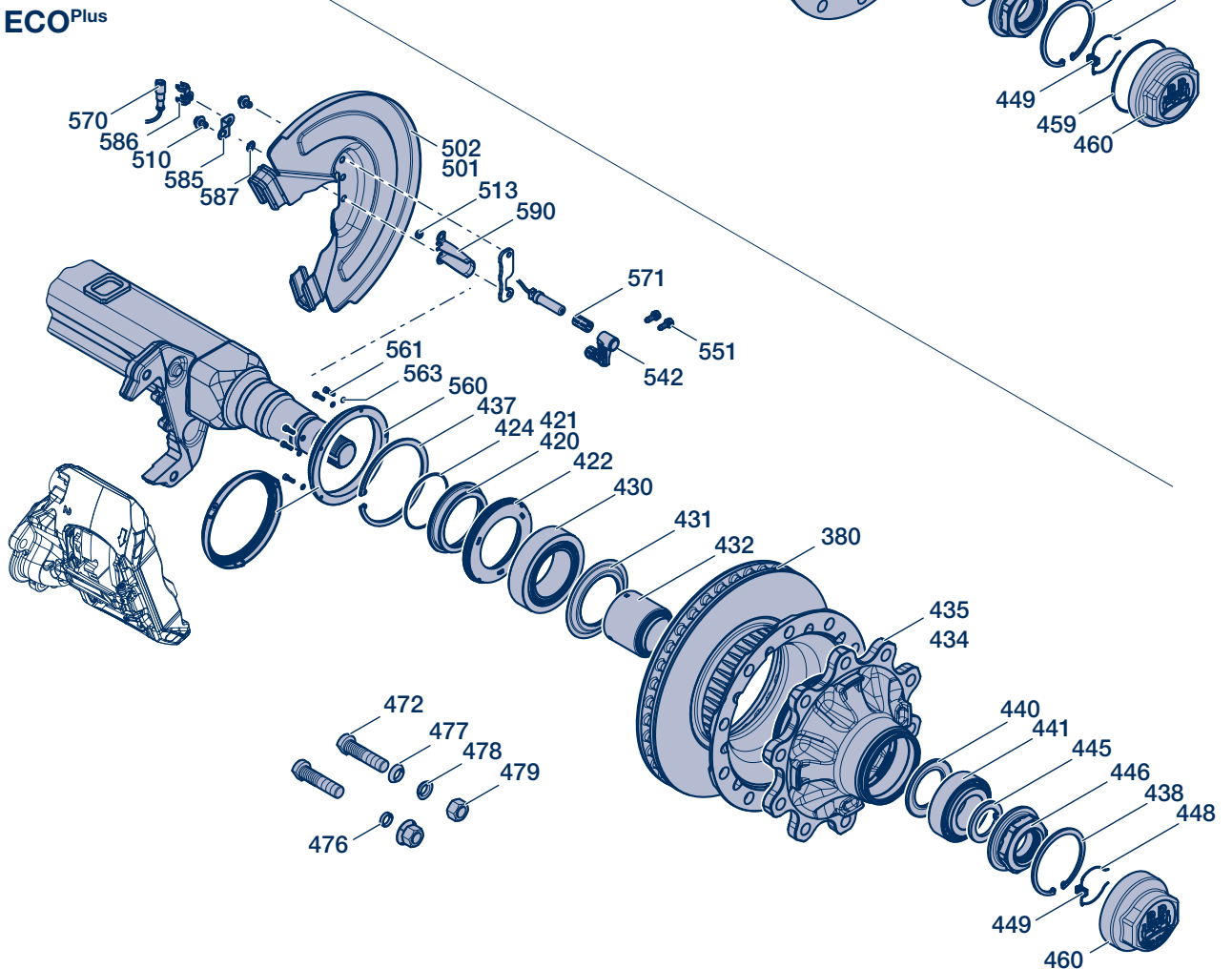
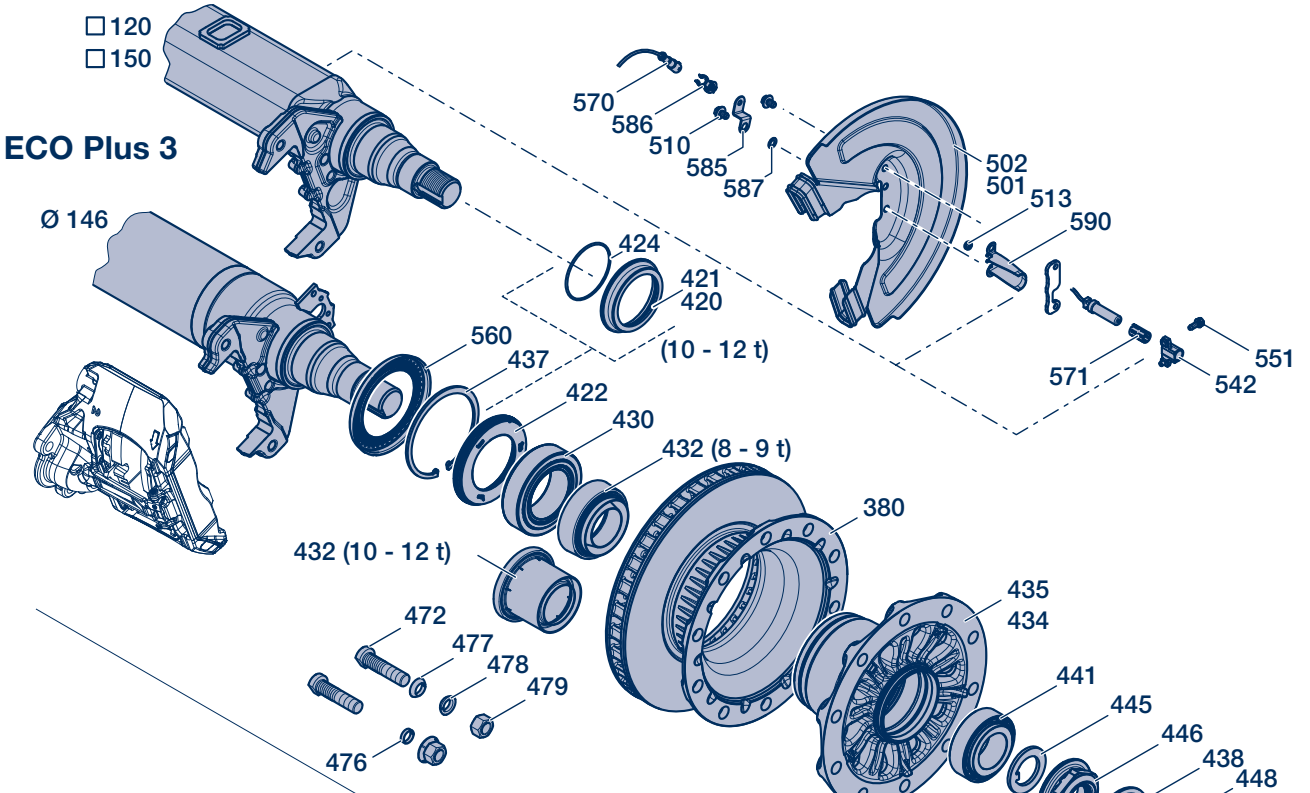

3 Name

Brake

Item	Name
325	Cylinder head screw
326	Guide pin, long (fixed bearing)
328	Guide bush (fixed bearing)
335	Sealing cap
336	O-ring
345	Cylinder head screw
346	Guide pin, short (floating bearing)
348	Guide bush (floating bearing)
354	Bellow
355	O-ring
356	Ring
363	Bellow with pressure plate
369	Sealing cap (370) with O-ring
370	Sealing cap
380	Brake disc
389	Wearing plate
390	Brake lining active (lining back plate with friction lining)
391	Brake lining passive (lining back plate with friction lining)
394	Clamping spring
395	Brake pad retaining clip
396	Bolt
397	Holding clamp
398	Split pin
410	Brake cylinder
411	Brake cylinder
530	Brake lining - dust cover

Axle

Item	Name
420	Thrust washer complete (item 421, 424)
421	Thrust washer
422	Lip seal
424	O-ring
430	Roller bearing
431	Dust cover
432	Grease cartridge
434	ECO unit (cpl. hub)
435	Hub
437	Locking ring
438	Locking ring
440	Thrust washer
441	Roller bearing
445	Washer
446	Axle nut
448	Hooked spring ring
449	Locking piece
459	O-ring (ECO Plus 3)
460	Hub cap
472	Wheel stud
476	Bush
477	Centering ring
478	Spring washer
479	Wheel nut
501	Dust cover
502	Dust cover
510	Locking screw
513	Cable protection
540	Attachment plate
542	Sensor bracket
551	Locking screw
560	Exciter ring
561	Cylinder head screw
563	Spring washer
570	Sensor
571	Bush for ABS
585	Support
586	Support for sensor connector
587	Serrated lock washer
590	Heat protection cover
702	Wear sensor set

Tightening torques 4

Item	Description	Thread / spanner size	Tightening torques
325, 345	Brake caliper fixing screws △ Use new fixing screws for every assembly! Threads and screw head contact surface are greased △	M 16 x 1.5 / AF 14	M = 260 Nm (250 - 270 Nm) or otherwise M = 150 Nm +180° rotation angle
335	Sealing caps of the caliper guide △ Use new sealing caps for every assembly! △	AF 14	M = 15 Nm (15 - 20 Nm)
410, 411	Attachment nuts for brake cylinder	M 16 x 1.5 / AF 24	M = 180 Nm (180 - 210 Nm)
410, 411	Spring brake bolt on spring brake cylinder		M = 40 Nm (30 - 50 Nm)
460	Hub caps ECO Pus 3 ECO ^{Plus}	AF 110 AF 110	M = 350 Nm M = 800 Nm
479	Wheel nuts	M 22 x 1.5 / AF 32 Stud alignment Spigot alignment Alloy wheels	M = 510 Nm (485 - 535 Nm) M = 630 Nm (600 - 660 Nm) M = 630 Nm (600 - 660 Nm)
510	Locking screws for dust cover	M 10 x 15 / AF 13	M = 25 Nm (23 - 28 Nm)
511	Locking screws for sensor bracket	M 8 x 20 / AF 13	M = 25 Nm (23 - 28 Nm)
561	Cylinder head screw for fastening the exciter ring	M 6 / AF 5	M = 8 Nm

5 Special tools

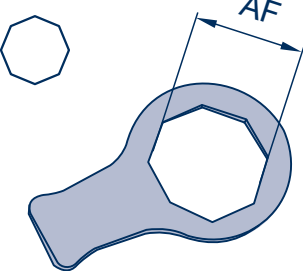
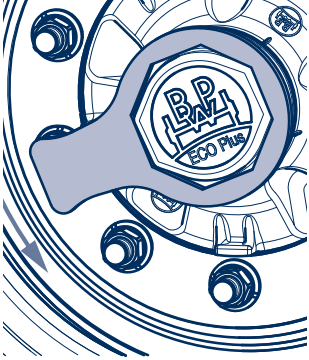
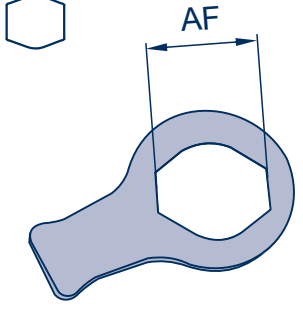
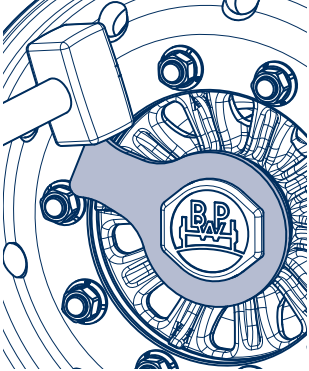
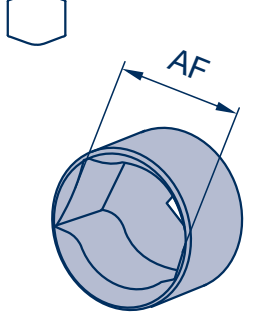
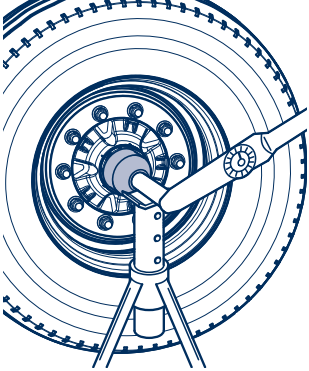
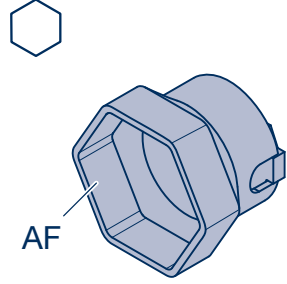
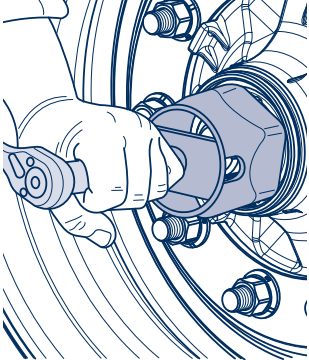
Consec. no.	Description	Illustration of tool	Tool in operation
1	Spanner for hub caps (flat shape) BPW item number: 03.339.05.08.0* AF 110 ECO Plus 3 * bent at right angle		
2	Spanner for hub caps (flat shape) BPW item number: 03.339.05.04.0 AF 110 ECO Plus 3/ ECO ^{Plus}		
3	Box spanner for hub caps (BPW shape) BPW item number: 03.364.29.03.0 AF 110 ECO Plus 3/ ECO ^{Plus}		
4	Box spanner for axle nuts BPW item number: 05.364.26.05.0 AF 95 ECO Plus 3/ ECO ^{Plus}		

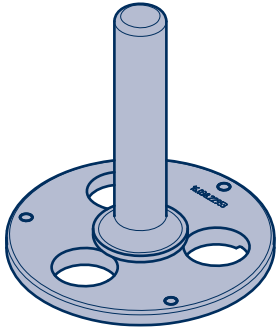
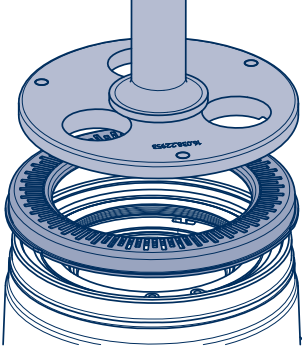
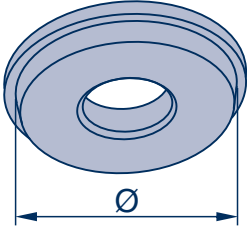
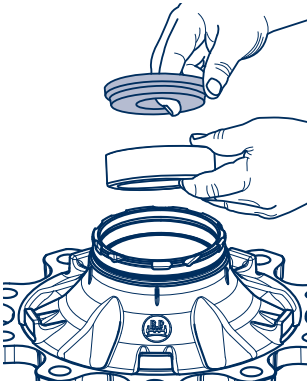
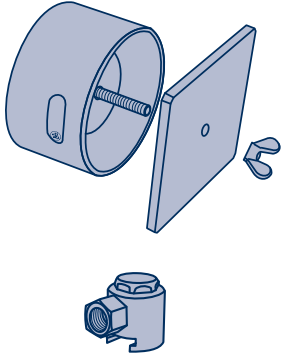
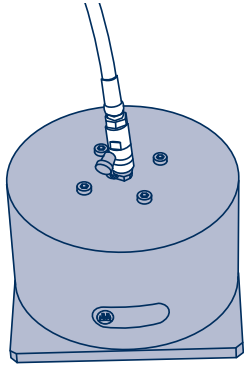
Consec. no.	Description	Illustration of tool	Tool in operation
5	Assembly aid for exciter ring BPW item number: 16.038.22953 ECO Plus 3		
6	Pressing tools, for pressing in the outer rings of roller bearings BPW item number: Roller bearing: 15.011.20052 Ø 142 33217 15.013.20052 Ø 113 33213		
7	Grease sprays for filling roller bearings with grease BPW item number: Roller bearing: 99.00.000.9.55 33118 / 33213 Complete set incl. adapter for flat-type grease nipple		

5 Special tools

↓ Brake tools ↓

ECO Disc tool case for TS2 / TSB

BPW item number:

99.00.000.9.72

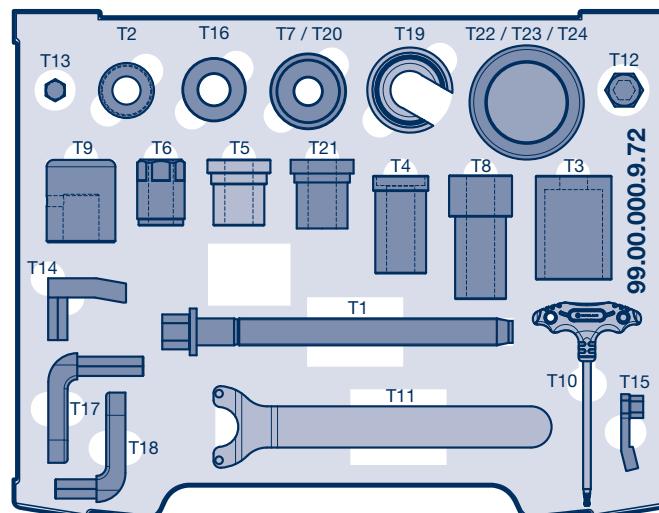

Consec. no.	Description	Illustration of tool	BPW item number:
T1	Threaded spindle		02.0130.39.10
T2	Ball bearing		02.0130.40.10
T3	Sleeve		02.1410.26.00
T4	Extractor tool for floating and fixed bearings		02.0130.41.10
T6	Nut		02.5270.37.00
T7 / T20	Retractable plate		02.1421.25.00
T8	Pressing tool for fixed bearing		02.0130.43.10
T21	Pressing tool for floating bearing		02.0130.72.20

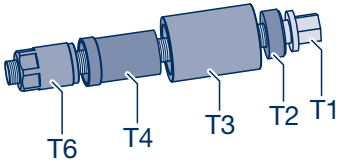
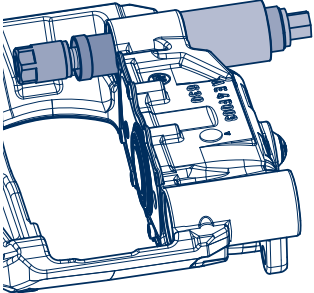
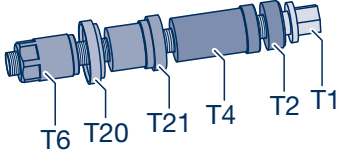
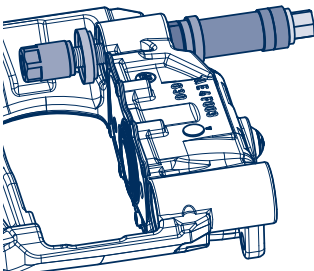
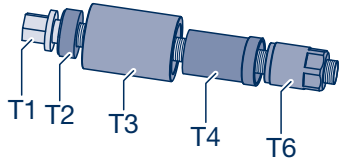
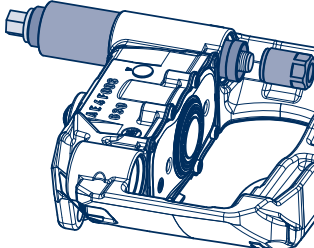
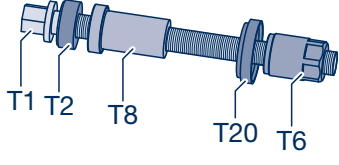
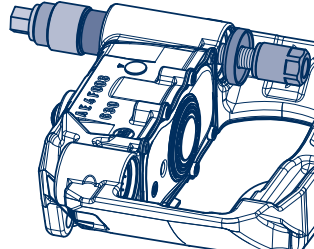
Consec. no.	Description	Illustration of tool	Tool in operation
	Extractor tool for floating bearing Tool component parts: T1, T2, T3, T4, T6		
	Pressing tool for floating bearing Tool component parts: T1, T2, T4, T6, T20, T21		
	Extractor tool for fixed bearing Tool component parts: T1, T2, T3, T4, T6		
	Pressing tool for fixed bearing Tool component parts: T1, T2, T6, T8, T20		

5 Special tools

ECO Disc tool case for TS2 / TSB

BPW item number:

99.00.000.9.72

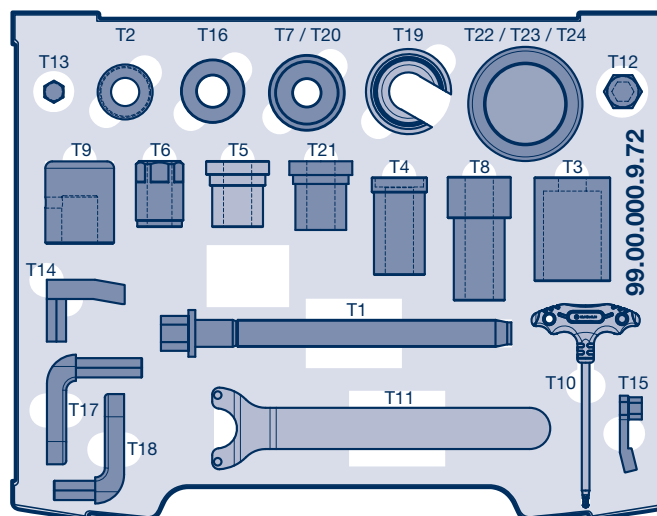

Consec. no.	Description	Illustration of tool	Tool in operation
T12	Adapter for moveable bearing bolt BPW item number: 02.0130.46.10 AF 14 / AF 24		
T13	Adapter for sealing cap BPW item number: 02.0130.47.10 AF 14 / AF 12		
T14	Adapter for torque wrench (floating bearing) BPW item number: 02.0130.48.10 AF 14		
T15	Adapter for torque wrench (sealing cap) BPW item number: 02.0130.49.10 AF 14		

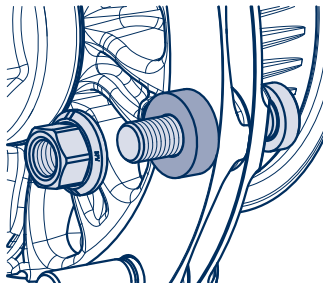
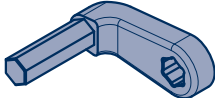
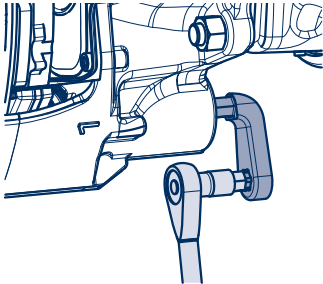
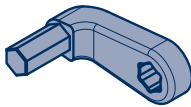
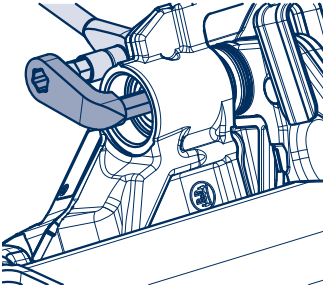
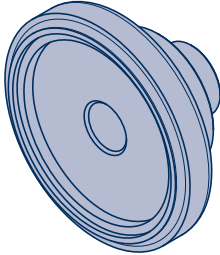
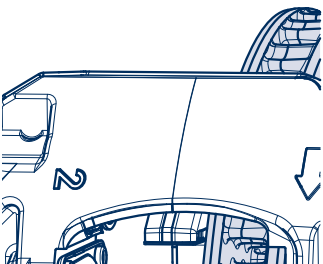
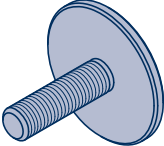
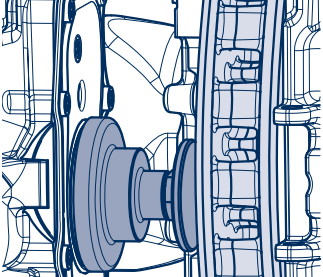
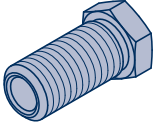
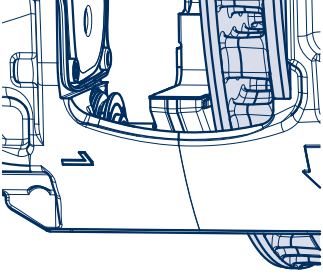
Consec. no.	Description	Illustration of tool	Tool in operation
T16	Ring for tightening the wheel studs BPW item number: 02.5683.92.00		
T17	Tool for fixed bearing bolt BPW item number: 02.0130.64.10 AF 14 / AF 14		
T18	Tool for moveable bearing bolt BPW item number: 02.0130.65.10 AF 14 / AF 14		
T22	Piston for bellow pressing tool BPW item number: 02.0130.74.20 Ø 83 / M 20 x 2		
T23	Screw for bellow pressing tool BPW item number: 02.0130.73.20 M 14 x 2		
T24	Spacer for bellow pressing tool BPW item number: 02.4319.42.00 AF 24 / M 20 x 2 / M 14 x 2		

5 Special tools

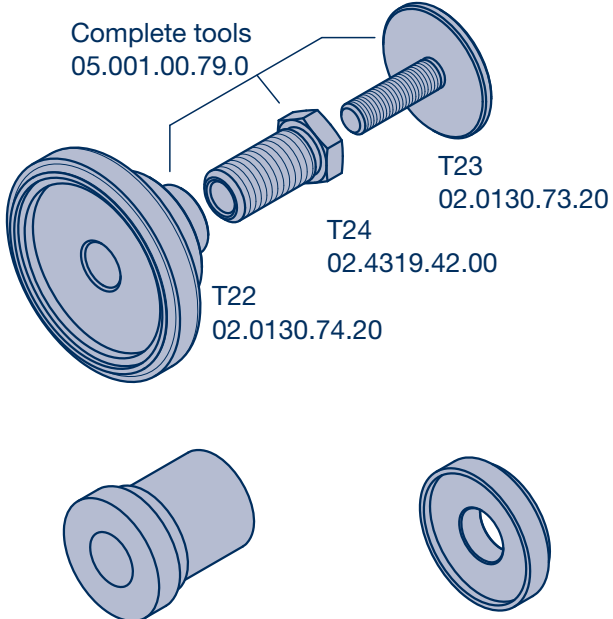
Description	Illustration of tool
<p>TS2 supplemental set for TSB tool case BPW item number: 09.801.08.82.0</p>	 <p>Complete tools 05.001.00.79.0</p> <p>T23 02.0130.73.20</p> <p>T24 02.4319.42.00</p> <p>T22 02.0130.74.20</p> <p>T21 02.0130.72.20</p> <p>T20 02.1421.25.00</p>

Lubrication and maintenance

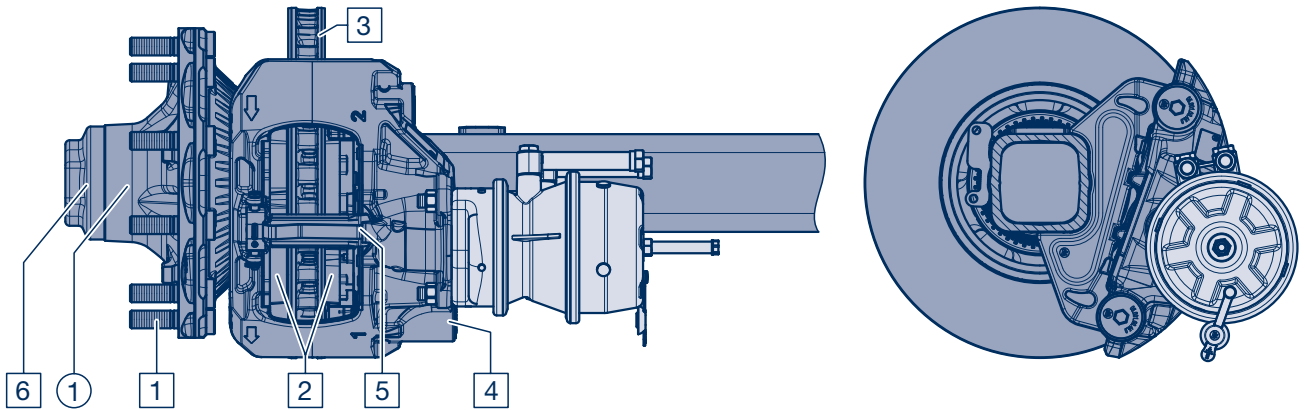

Lubrication and maintenance

Overview

For detailed description see pages 22 - 31

	initially	every 12 weeks ¹⁾	every 26 weeks ¹⁾	annually and at every brake lining replacement	every year	every 2 years	every 3 years	after 5 years, then every 3 years
Lubrication work (lubrication with BPW special longlife grease ECO-Li^{Plus})								
① Change wheel hub bearing grease, check roller bearings and oil seal for wear. ECO Plus Unit								①
On-road conditions								①
Off-road conditions							①	①
On-road conditions ³⁾					①	①		
Off-road conditions ³⁾					①			

Maintenance								
① Check wheel nuts for tight seat.	① ²⁾							
② Check brake lining thickness.		②						
- Visual inspection, check all components for damage, wear and corrosion.			-					
③ Check the brake disc for cracking and undersize.		③ ³⁾	③					
④ Check brake caliper guide system.		④ ³⁾	④					
⑤ Check bellow with pressure plate.			⑤ ³⁾	⑤				
⑥ Check the play of the bearing of the ECO Unit; adjust if necessary.				⑥				

¹⁾ For heavy-duty applications, check or lubricate more frequently (e.g. off-road, heavy-duty braking work).

²⁾ After the first run under load conditions as well as after each wheel change.

³⁾ For use outside Europe:

Note: Components that have been damaged due to an improper attachment are to be replaced if necessary after a review by a BPW Service Centre.

ECO^{Plus} Unit

- in Europe, for the first time after 5 years in on-road usage or every 3 years in off-road usage, then at least every 3 years depending on the operating conditions -
- outside of Europe, every 2 years in on-road usage or every year in off-road usage -

TS2 4309 (10 t):

Dismantling and assembling the ECO^{Plus} Unit and brake, see chapter 14.1 Changing the brake disc, work steps [1] - [10] and [29] - [46].

Dismantling and assembling the ECO^{Plus} Unit (with grease or bearing change), see chapter 15.2.

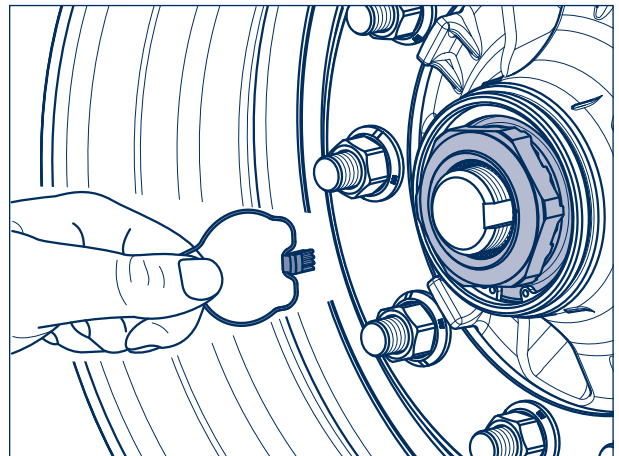

TS2 3709 (10 t):

Dismantling and assembling the ECO^{Plus} Unit and brake, see chapter 14.2 Changing the brake disc, work steps [1] - [18] and [35] - [55].

Dismantling and assembling the ECO^{Plus} Unit, see chapter 15.2.

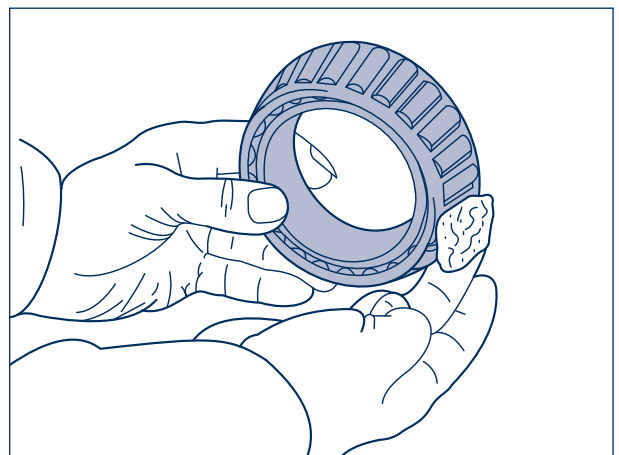

Recommendation:
 Replace the roller bearings after 5 years in on-road usage and after 3 years in off-road usage.

ECO^{Plus} Unit

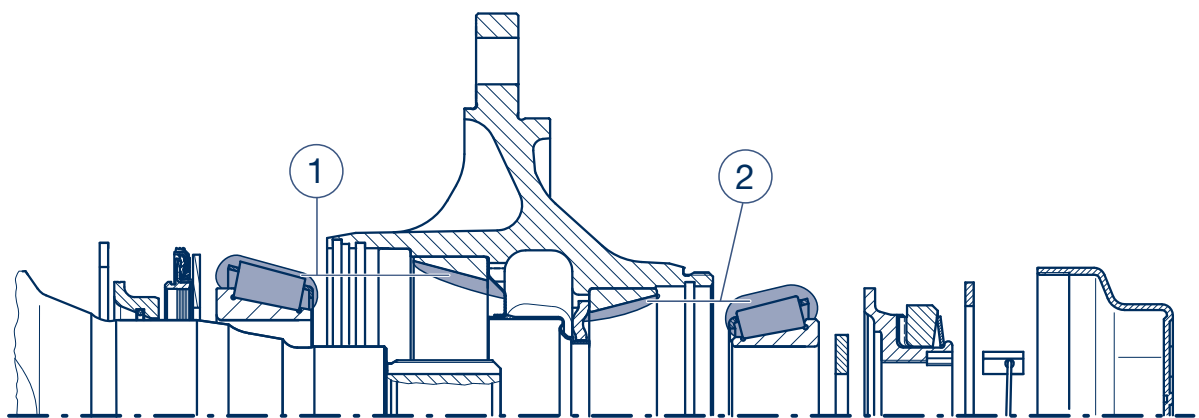

BPW special longlife grease ECO-Li^{Plus}

Quantity of grease per roller bearing

	① inner	② outer
Manual lubrication	170 g	120 g
Lubrication with a grease spray	130 g	90 g

6 Lubrication and maintenance

Maintenance

- 1 Check wheel nuts for tight seat**
 - The tightening torque of the wheel nuts must be checked after the first run under load as well as after each wheel change and retightened to the prescribed value if necessary -

Tighten the wheel nuts crosswise with a torque wrench to the tightening torque given in the table.

Attention: Do not exceed the specified settings!

The wheel contact surfaces should not have additional coats of paint (risk of the disc wheels becoming detached)!

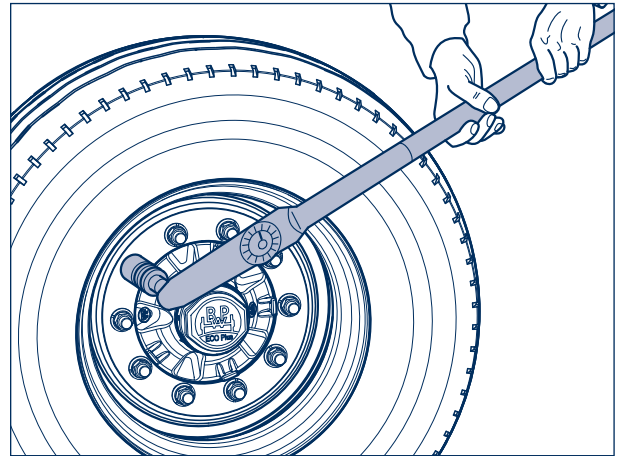

Tightening torques for wheel nuts

The prescribed tightening torques must be observed in order to ensure that the wheels are securely fastened! The wheel studs must be clean and free of damage, and the nuts must be easily tightened and loosened. If necessary, lightly oil the contact surface between the wheel nut and the pressure plate. Do not oil or grease the thread of the wheel studs and wheel nuts.

The use of aggressive and acidic rim cleaners is not permitted. Such agents can seriously impair the anti-corrosion coating of wheel bolts and wheel nuts.

Stud alignment	Tightening torque	
M 22 x 1.5	510 Nm (485 - 535 Nm)	

Spigot alignment	Tightening torque	Wheel nut with pressure plate
M 22 x 1.5	630 Nm (600 - 660 Nm)	
M 22 x 1.5 alloy wheels	630 Nm (600 - 660 Nm)	

2 Check brake lining thickness
 – quarterly –

Check the brake lining thickness regularly, e.g. when checking the tyre pressure, or after 3 months at the latest.

Warning!
Worn brake linings reduce the braking performance and can ultimately cause the brakes to fail completely!

Inspection can be done as follows:

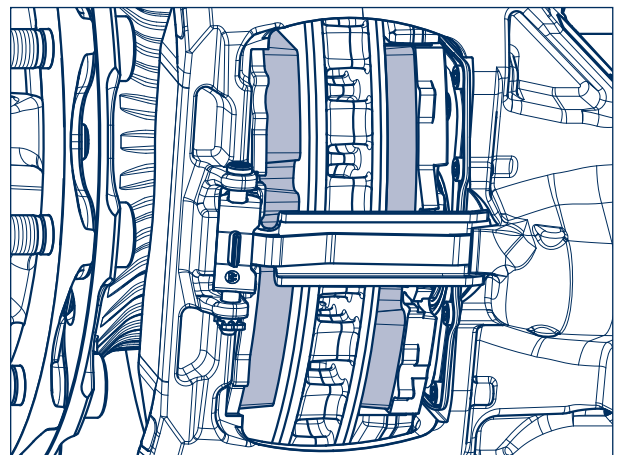

The brake lining thickness can be checked by the position of the brake caliper in relation to the welded-on brake anchor with the wheels mounted (approximate wear indicator).

Dimension x (distance between brake caliper and brake anchor):

12 mm => new condition

TS2 3709 / 4309

31 mm => max. permissible brake lining wear
 19 mm

35 mm => max. permissible wear for brake lining and brake disc

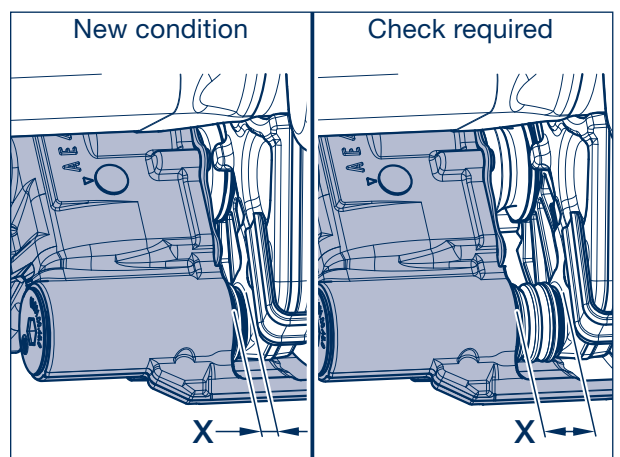

The brake linings must be removed to inspect them more closely; see chapter 8.

Scorched, glazed over, or oily brake linings must be replaced immediately.

The remaining brake lining thickness must **not** be less than 2 mm (check with a caliper gauge).

Small ruptures at the edges are allowed; large ruptures on the surface of the friction linings are not permitted.

Repair note!
Only replace brake linings on the same axle at the same time!

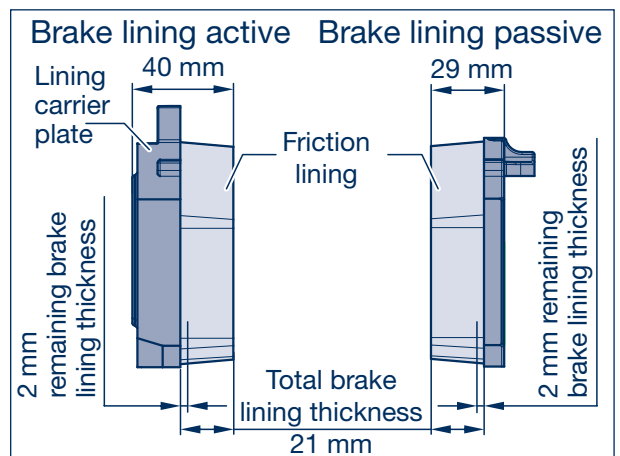

- Visual inspection
 – every six months –

Check all components for damage, wear and corrosion.

6 Lubrication and maintenance

3 Brake disc

(Checking the condition of the brake disc)

- Every six months when used within Europe and every three months when used outside Europe –

Sections **A - D** (fig.) show the possible conditions of the disc surface:

- A** → Network-type cracks = permissible
- B** → Radial cracks up to max. 1.5 mm width and depth = permissible
- C** → Uneven disc surface less than 1.5 mm = permissible
- D** → Continuous cracks = **not permissible**

Technical data:

Disc thickness, new = 45 mm
 Minimum permissible disc thickness = 37 mm
 Maximum wear per side = 4 mm
 (check with a caliper gauge where the brake linings make contact).

In the case of surface conditions as described for sections **A - C**, the brake disc can be used until the minimum permissible disc thickness has been reached.

Changing brake discs (see chapter 14).



Repair note!

To prevent the brake disc from being damaged, the brake linings must be replaced at the latest when the brake lining thickness has been measured at 2 mm over the carrier plate.



Repair note!

Brake discs should always be replaced on the same axle at the same time. The brake linings should also be replaced when new brake discs are installed.



Warning!

If these instructions are not followed, the brake disc can be damaged and the braking effect can decrease or completely fail when the brake linings are worn down.

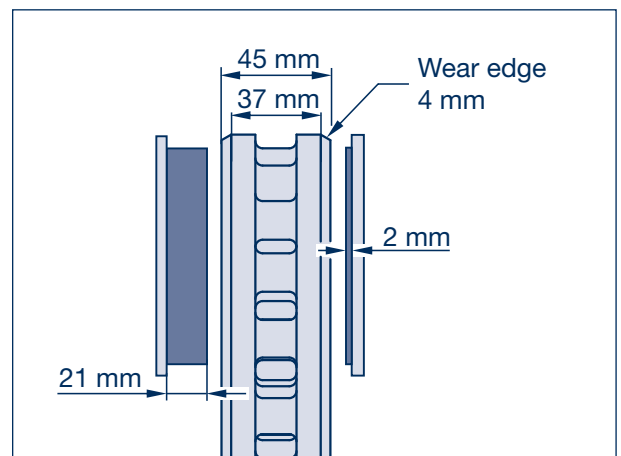
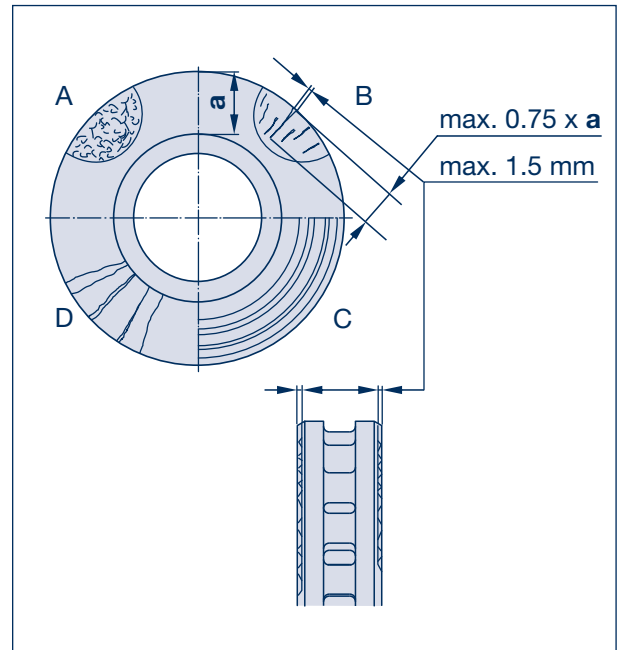

4 Check the brake caliper guide system

(check clearance and adjustment)

- Every six months when used within Europe,
every three months when used outside Europe –
(e.g. within the scope of the statutory checks)

**Secure the vehicle from rolling away.
Release the service and parking brake.**

The brake cylinder and attachment parts for the brake linings can remain fitted.

Forcefully pushing the sliding caliper in the direction of the axle must cause the caliper to move approximately 0.7 to 1.6 mm (clearance).

If the clearance is not within the tolerance, the brake caliper guide and the adjustment should be checked (see page 28).

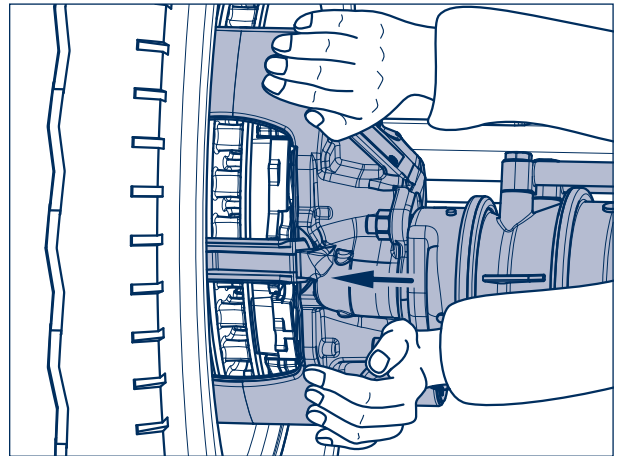

Close examination of the clearance with
the wheels mounted:

Use a dial gauge to determine the clearance.
For this purpose, attach a dial gauge holder to the axle beam and position the probe on the outside of the fixed bearing sealing cap (335) or on the brake cylinder.

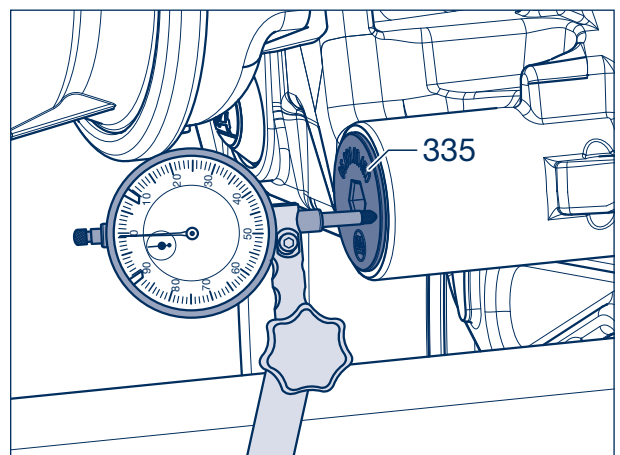

Close examination of the clearance with
the wheels removed:

Use a feeler gauge to check the clearance.

Forcefully push the sliding caliper in the direction of the axle centre. Insert the feeler gauge between the bellow with pressure plate (363) and the brake lining back plate (390).

If the clearance is not within the tolerance, the adjustment and the brake caliper guide should be checked.

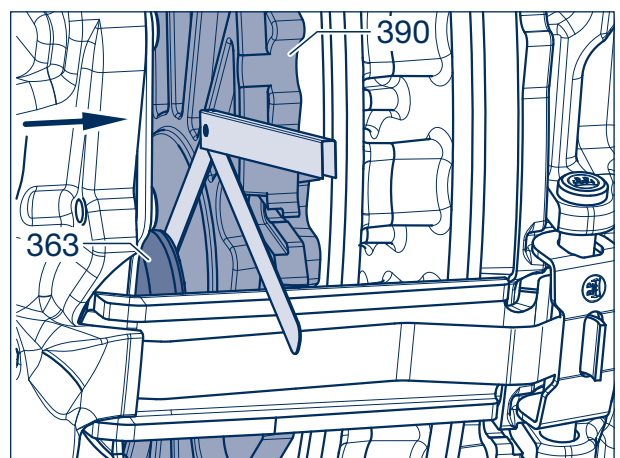

6 Lubrication and maintenance

Only if clearance NOK:

Adjusting the clearance and checking the adjustment

1. Remove the sealing cap (370).
 2. Turn the resetter with a spanner (AF 13) 90° **counterclockwise**.
- Max. reset moment: 15 Nm**
3. Actuate the brake 5 to 10 times with approx. 2 bar.
 4. When the sliding caliper is forcefully pushed in the direction of the axle, it must now be possible to move the sliding caliper by the clearance of 0.7 - 1.6 mm.

If the clearance is correctly set, the adjustment is OK.

5. A new seal cap (vented) must be used. Squeeze it and press it into the brake caliper (follow the instructions in chapter 8.2, Changing brake linings, on page 38 of the installation instructions).



Warning!

If the instructions are not followed properly and the cap is not fitted correctly, there is a risk of moisture getting into the brake and corroding the adjuster. This can reduce the braking effect or even cause it to fail completely.

Checking the brake caliper guide:

The brake caliper guide must be checked if the clearance has not been adjusted correctly.

Disassemble the brake linings, see chapter 8. It must be possible to move the brake caliper slightly from end stop to end stop.

The guide bushes (328, 348) are sealed by the bellows (354) and the sealing caps (335).

Inspect the bellows and sealing caps for cracks, damage, and proper seating and replace them if necessary.

Sealing caps that have been removed must be replaced by new ones.

Overhauling the brake caliper guide, see chapter 12.

Check the brake caliper bearing play:

The bearing play of the brake caliper can be determined using a dial gauge. Attach the dial gauge holder to the axle beam and position the gauge on the brake caliper housing on the brake cylinder holder.

Press the brake caliper on the brake cylinder downwards vertically to its installation position and set the dial gauge to "zero".

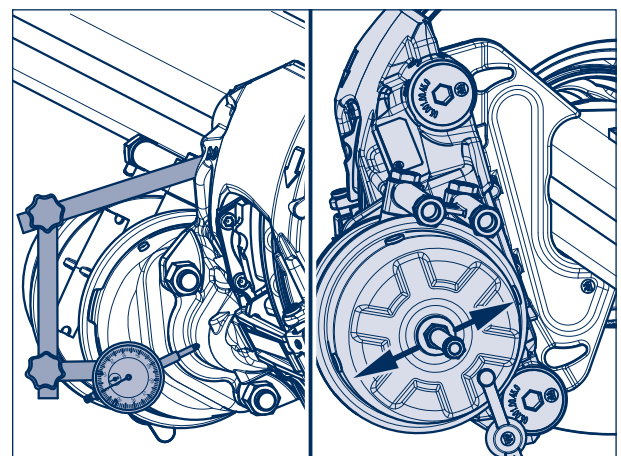
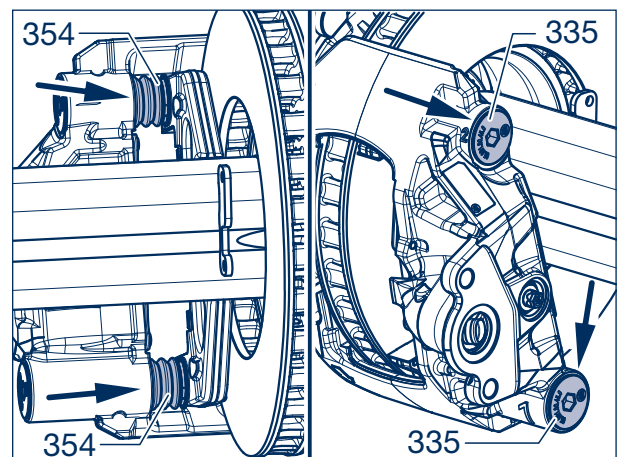
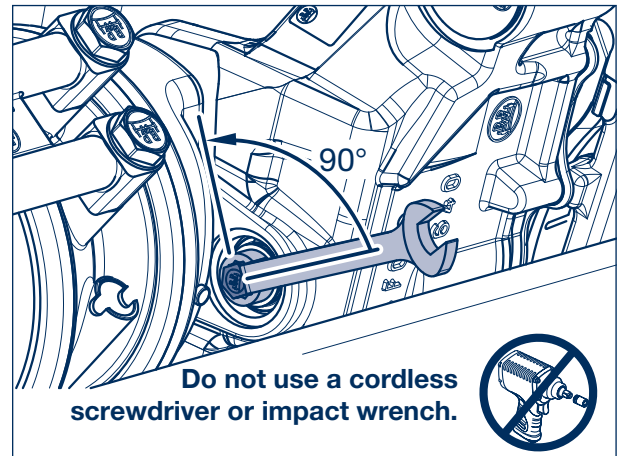

Press the brake caliper upwards and determine the play of the bearing on the dial gauge.

If the play of the bearing of a brake caliper exceeds 1.0 mm, the brake caliper bearing must be replaced.

- 5 Check the bellow with pressure plate**
 – at every brake lining replacement and at the latest annually,
 every six months when used outside Europe –

Secure the vehicle from rolling away.
 Release the service and parking brake.

Disassembling brake linings (390, 391), see chapter 8.

The service brake and spring brake must be in the released condition.

Pull the pressure plate with heat protection cover and bellow (363) out of the dust cover slightly.
 Check the complete unit for proper seating and damage; replace it if necessary.

Check the dust cover (arrow) for deformation. If a deformation is detected, the brake caliper must be replaced!

If a thermal overloading of the brake has been detected, the bellow with pressure plate (363) must be replaced.

Before the new bellow with pressure plate is installed, the adjusting unit must be checked for corrosion and ease of movement .

After the check or replacement, the bellow must be folded correctly and returned to its initial position. The pressure plate rests against the threaded sleeve (see figure 1 on page 32).



Repair note!
The bellow with pressure plate must be replaced each time that the brake disc is changed.

Changing the bellow with pressure plate, see chapter 11.



Repair note!
The penetration of dirt and moisture causes corrosion and affects the operation of the clamping mechanism and adjustment.

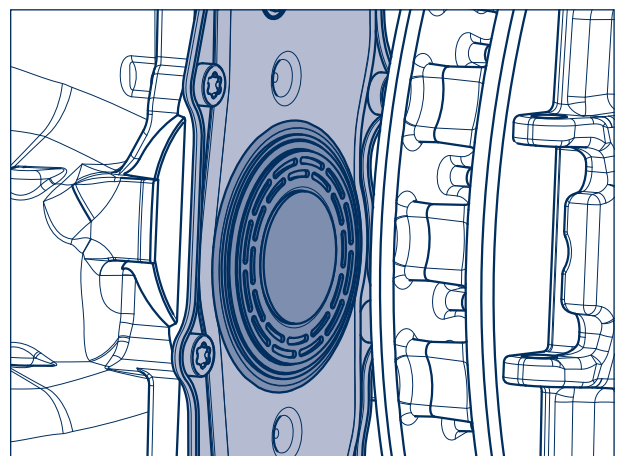
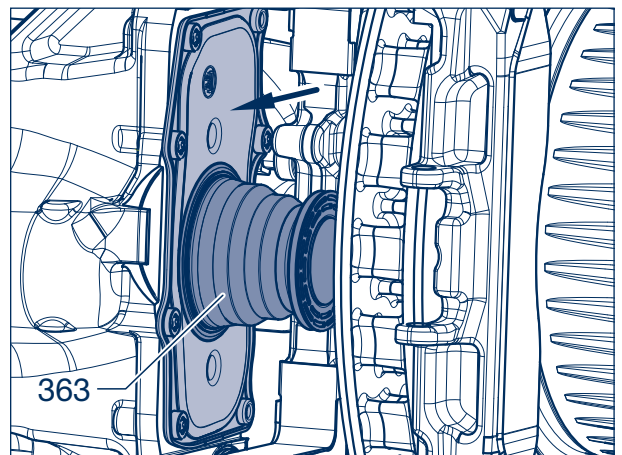

6 Lubrication and maintenance

- 6 **Check the play of the bearing of the wheel hub**
– at every brake lining replacement, at the latest annually –

**Secure the vehicle from rolling away.
Release the service and parking brake.**

In order to check the play of the bearing of the wheel hub, lift the axle until the tyres are off the ground. Release the brake. Apply a lever between the tyre and the ground and check the clearance.

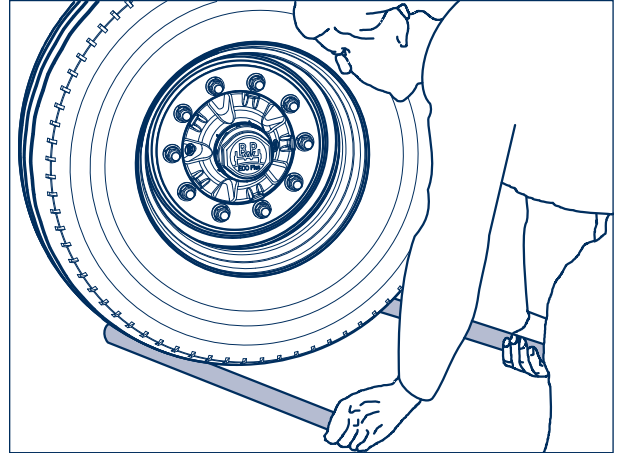

If a play of the bearing is detected on the **ECO Plus 3 Unit**:

Adjust the play of the bearing:

1. Unscrew the hub caps.
2. Remove the hooked spring ring with a wedge from the axle nut.
3. Tighten the axle nut whilst continuously rotating the ECO Plus 3 Unit with a hexagon socket spanner. The ECO Plus 3 Unit must rotate several times before the tothing slips over the axle nut.

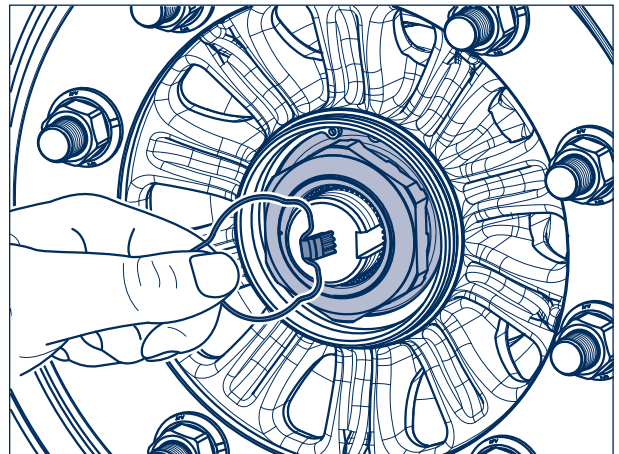

Attention!
Do not use an impact wrench.

4. Fit the locking piece in the groove between the axle stub and the nut (do not turn back the axle nut).
5. Hook the hooked spring ring behind the formed edge of the axle nut.
6. Insert a new O-ring into the groove (arrow) of the wheel hub. Apply a thin coat of BPW special longlife grease ECO-Li^{Plus} to the hub cap in the area of the O-ring contact surface and thread.
7. Screw on the hub cap and tighten it to **350 Nm**.

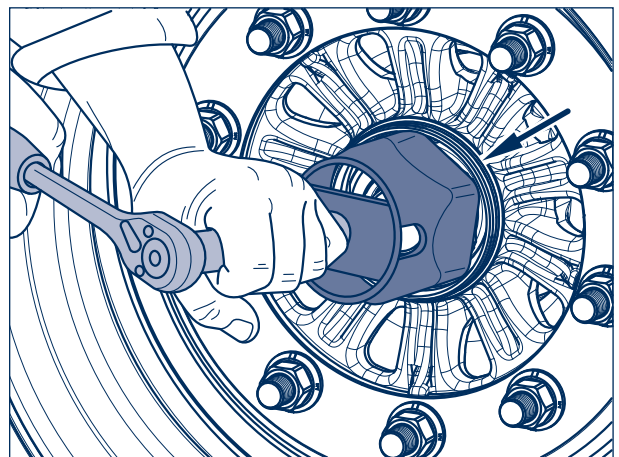

If a play of the bearing is detected on the **ECO^{Plus} Unit**:

Adjusting the play of the bearing:

1. Unscrew the hub caps.
2. Remove the hooked spring ring with a wedge from the axle nut.
3. Tighten the axle nut using a hexagon socket spanner (BPW no. 05.364.26.05.0) whilst continuously rotating the ECO^{Plus} Unit. The ECO^{Plus} Unit must rotate several times before the tothing slips over the axle nut.



Attention!
Do not use an impact wrench.

4. Fit the locking piece in the groove between the axle stub and the nut (do not turn back the axle nut).
5. Hook the hooked spring ring behind the formed edge of the axle nut.
6. Screw on the hub caps and tighten them to 800 Nm.

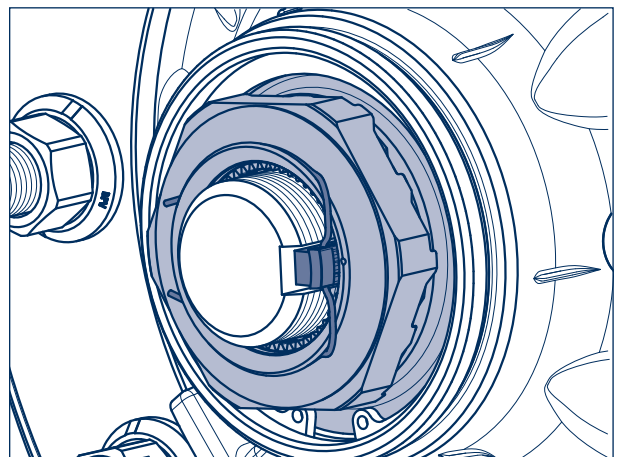
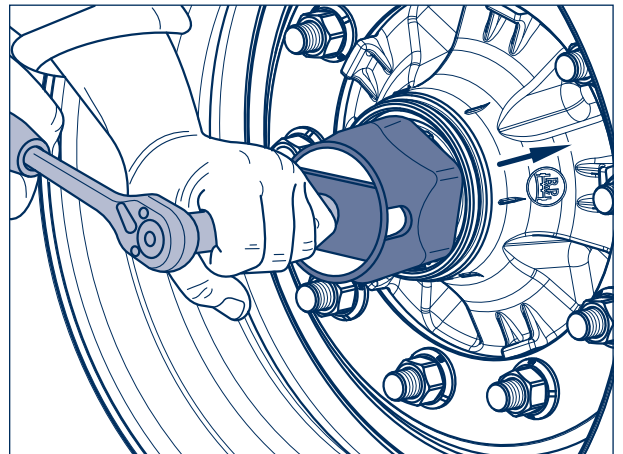
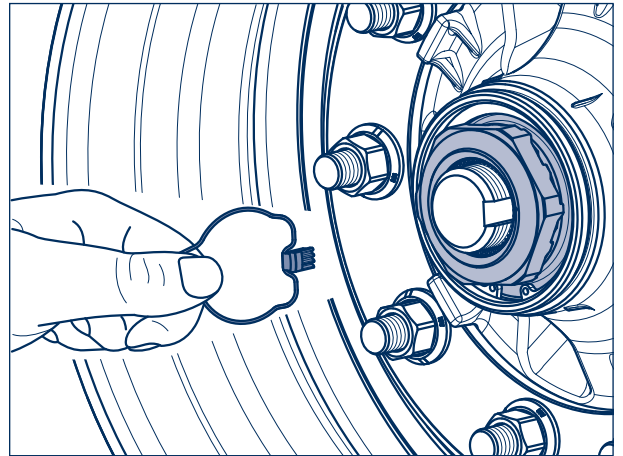

7 Structure and function

FUNCTION

PRINCIPLE: SLIDING CALIPER BRAKE

7.1 Applying the brake

During braking, the push rod of the spring brake or diaphragm cylinder presses onto the brake lever (1).

The offset position of the brake lever amplifies the force created by the brake cylinder and allows it to be transferred to the traverse (3) via a needle bearing (2).

This clamping force acts on the inner brake lining (5a) via the traverse and the threaded sleeve (4).

Once the clearance between the inner brake lining and the brake disc (6) has been overcome, the reaction force is transferred to the outer brake lining (5b) via the brake caliper.

The braking moment for the wheel results from the contact pressure of the brake linings on the brake disc.

The radial stabilizer force created by the responding brake lining at this time is transferred directly to the axle via the brake caliper.

7.2 Releasing the brake

When the braking pressure decreases, the pressure springs (7) move the brake actuating unit back to its initial position.

7.3 Adjustment

The brake is fitted with an automatic non-wearing adjusting device to maintain a constant clearance between the brake linings and the brake disc.

Each brake application also simultaneously actuates the adjustment hub (9), which is coupled with the brake actuating unit via a shift sleeve (10), via an adjustment pin (8) in the brake lever. A reset shaft (11) with toothed washer (12) connected to the shift sleeve defines the clearance of the disc brake via the tooth pitch.

When the clearance increases due to brake lining and brake disc wear, the threaded sleeve (4) is turned by the degree of wear through adjustment via a wrap spring (13).

When the clearance is correctly set, the wrap spring slides through without turning the threaded sleeve.

The overall clearance (total clearance on both sides of the brake disc) measures 0.7 to 1.6 mm.

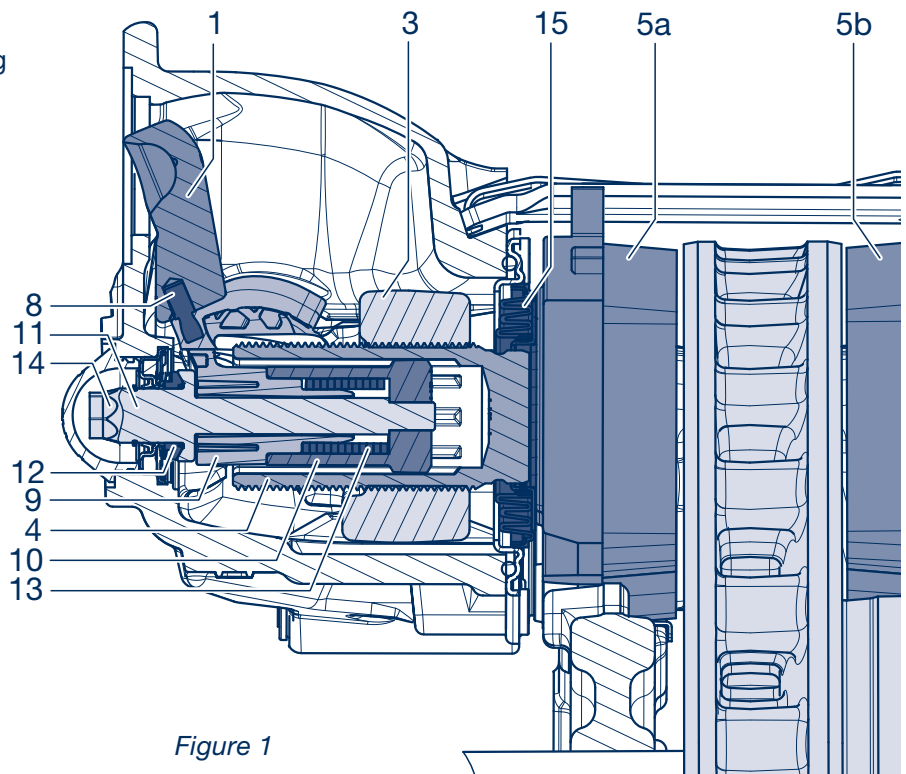

Figure 1

7.4 Reset mechanism

The disc brake features a reset mechanism at the back for replacing the brake linings and brake disc.

To reset the threaded sleeve to its initial position, the reset shaft equipped with a hexagon connection (14) is moved back using a slight torque, or the clearance of the brake is preset.

7.5 Brake cylinder

When compressed air is applied to the brake cylinder, an air cushion forms behind the diaphragm.

This forces the push rod out of the cylinder via the diaphragm plate.

The brakes may only be fitted with brake cylinders which - apart from the sealing of the flange surface - are fitted with a so-called "inner sealing".

This means that the push rod acting on the lever (1) must be hermetically sealed from the secondary chamber of the brake cylinder, as otherwise the clamping mechanism will be completely open to its surroundings.

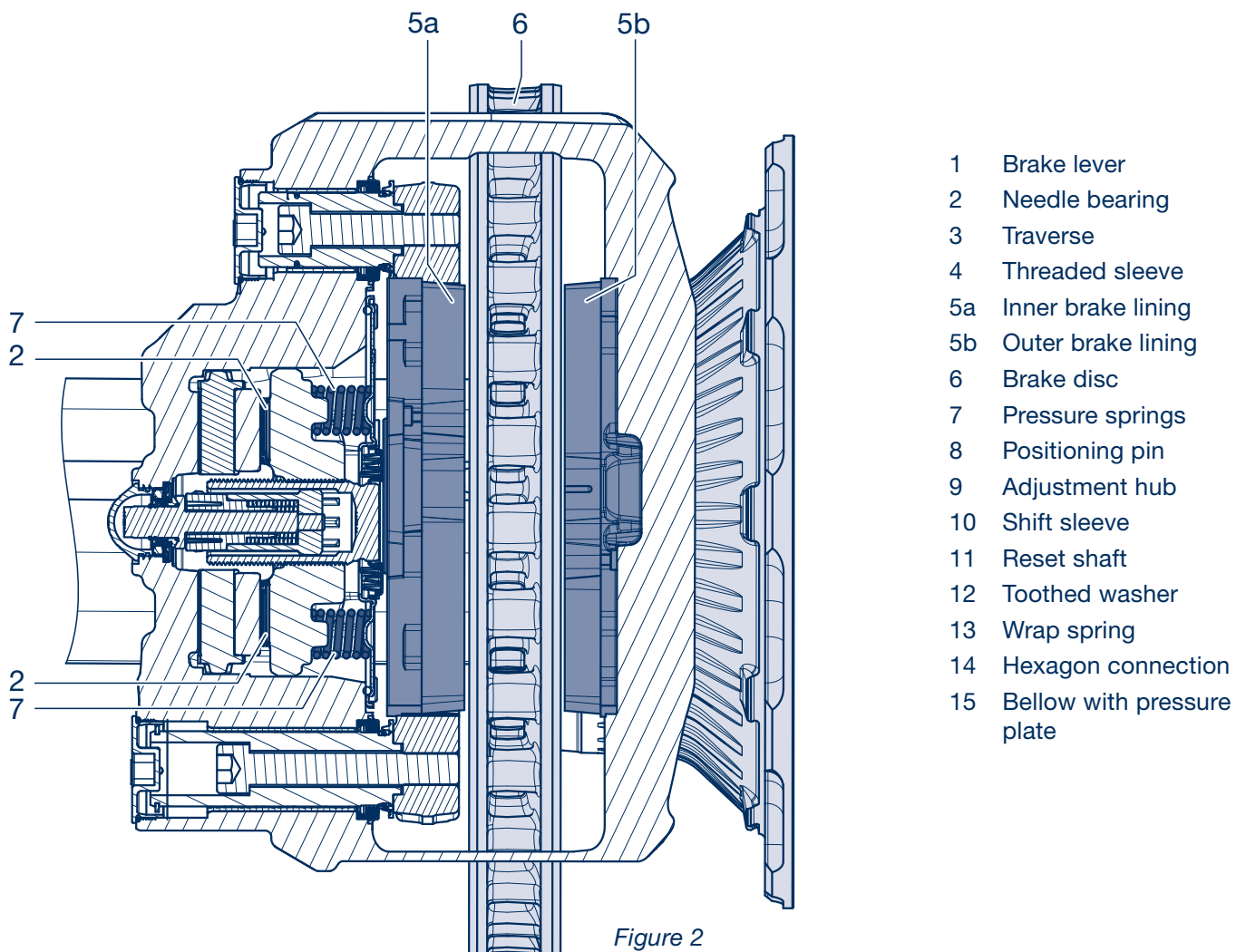

Figure 2

8 Changing the brake linings



Repair note!

Only replace brake linings on the same axle at the same time!
Before the brake linings are installed, the brake must be reset completely.

- [1] Prevent the vehicle from rolling away.
- [2] Release the service and parking brake and remove the wheels.
- [3] Remove the sealing cap (370) of the resetter with a screwdriver.

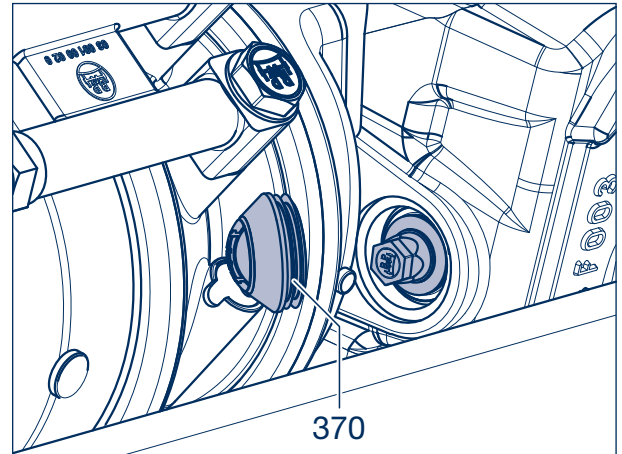

Figure 1

8.1 Resetting the threaded sleeve

- [4] Using a spanner (AF 13), turn the resetter counter-clockwise until the pressure plate with bellow has been completely reset. (If nec., manually turn back the pressure plate with bellow to the compressed condition.)

Max. reset moment: 15 Nm



Repair note!

If the max. reset torque is exceeded, the adjustment can be irreparably damaged.



Attention!

Do not use a cordless screwdriver or impact wrench. Using these tools would cause considerable damage!

- [5] Remove the brake pad wear sensing (702) if fitted; see page 41.
- [6] Pull the spring split pin (398) out of the bolt (396) with a spring plier.

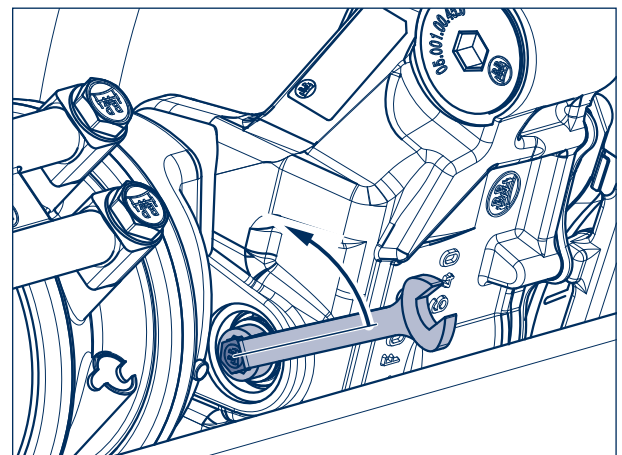

Figure 2

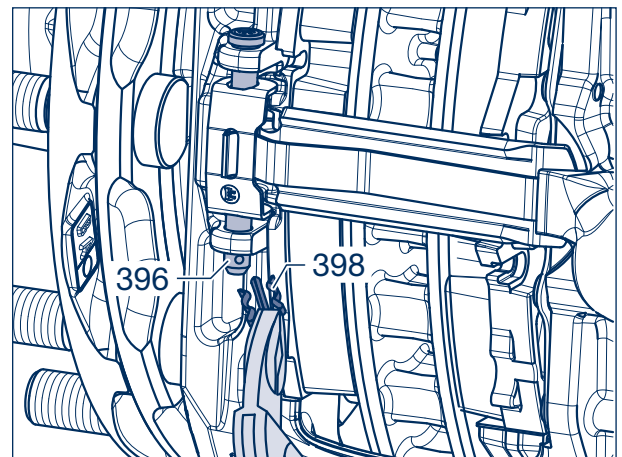

Figure 3

- [7] Depress the clamping spring (394) and remove the bolt (396) with holding clamp (397).
- [8] Remove the brake lining - dust cover (530) if fitted; see page 43.

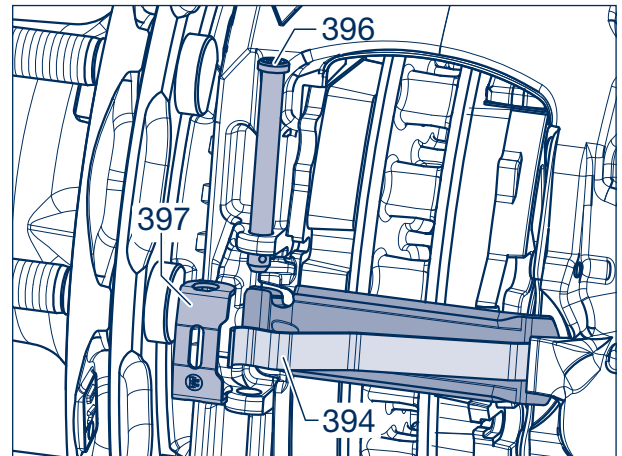

Figure 4



Caution!
Apply counter pressure to the brake linings (390, 391) if necessary so that they do not fall out of the lining groove when the pad retainer is removed.

- [9] Remove the pad retainer (395) with clamping spring (394).

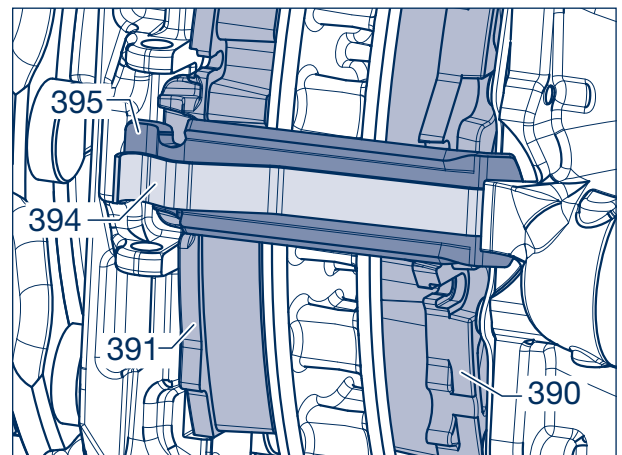

Figure 5

- [10] Remove the brake linings (390, 391).
- [11] After the brake linings have been removed, check the condition of the brake and the brake disc; see chapter 6, pages 27 to 29.
- [12] If no defects are found, you can continue with the replacement of the brake linings (390, 391).

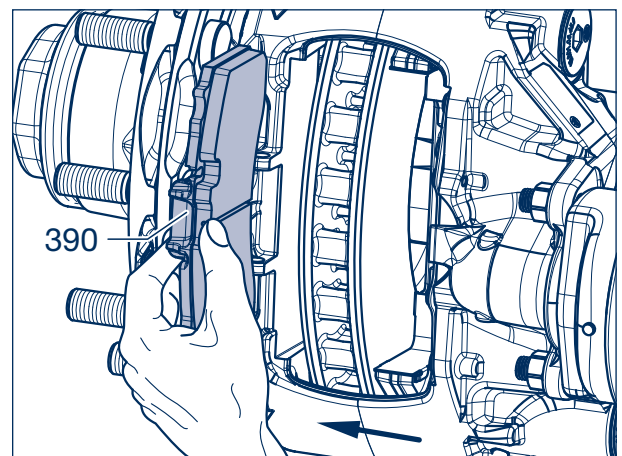

Figure 6

8 Changing the brake linings

- [13] Lever both wearing plates (389) off of the brake anchor. Clean the lining groove and the seats of the wearing plates on the brake anchor and remove corrosion.
- [14] Mount new wearing plates (389), greased on the rear side with BPW special longlife grease ECO-Li^{Plus}, on the brake anchor. The lateral mounting brackets (arrow) fix the plates on the brake anchor.



Repair note!

The brake disc must remain free of grease.



Note:

Use only brake linings approved by BPW. Our warranty will become invalid if this instruction is not observed!



Repair note!

If the brake disc is worn, the inner and outer radius (arrow) of the new linings must be chamfered (4 x 45°).



Repair note!

Before the brake linings are installed, it must be ensured that the bellow with pressure plate (363) rests correctly folded against the dust cover (see figure on page 29).

- [15] Move the brake caliper towards the inside of the vehicle and insert the inner, active brake lining (390).



Note:

The brake linings are supplied with different back plates.

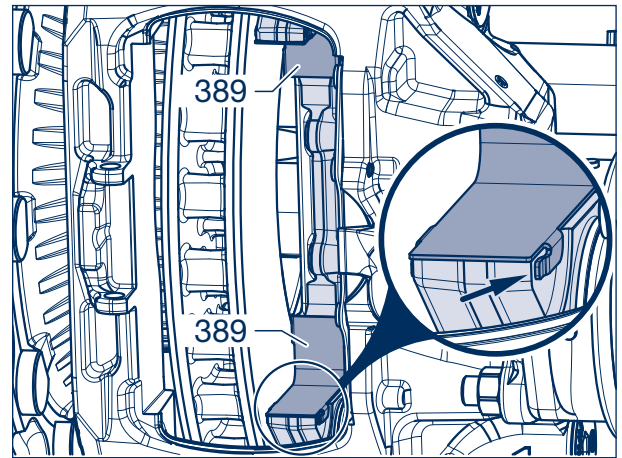

Figure 7

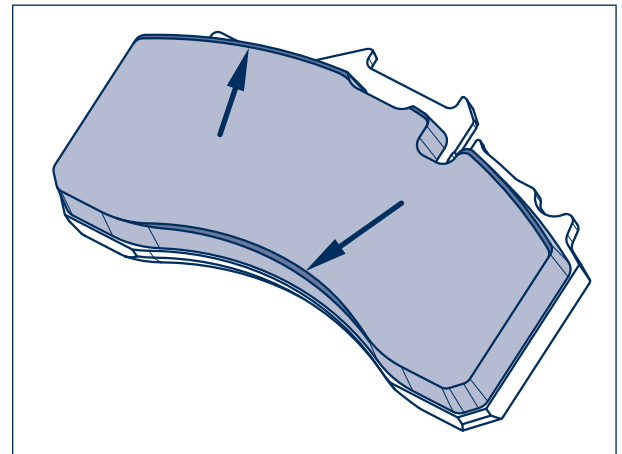

Figure 8

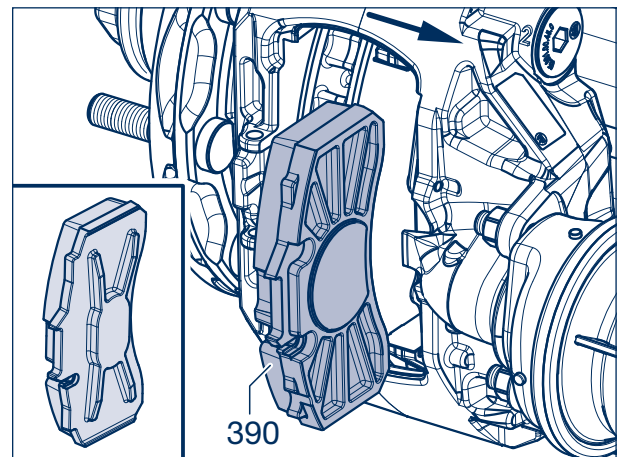

Figure 9

- [16] Slide the brake caliper towards the outside of the vehicle and insert the outer, passive brake lining (391).

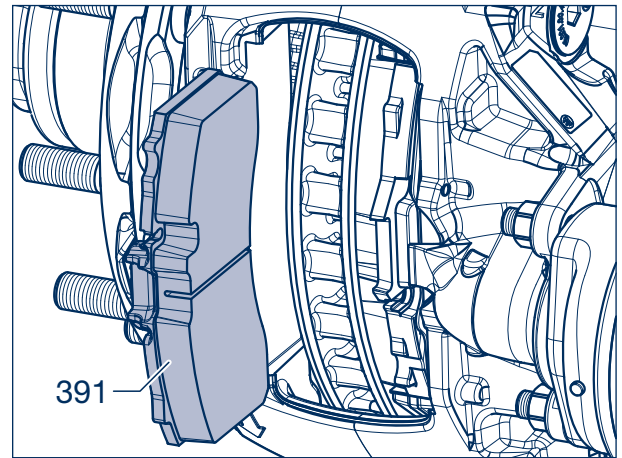

Figure 10

- [17] Guide the pad retainer (395) with clamping spring (394) into the saddle opening.
- [18] Place the holding clamp (397) onto the clamping spring and press it down together with the pad retainer until the bolt (396) can be inserted into the bore hole.
- [19] Install the brake lining - dust cover (530) if has been removed (see page 43).

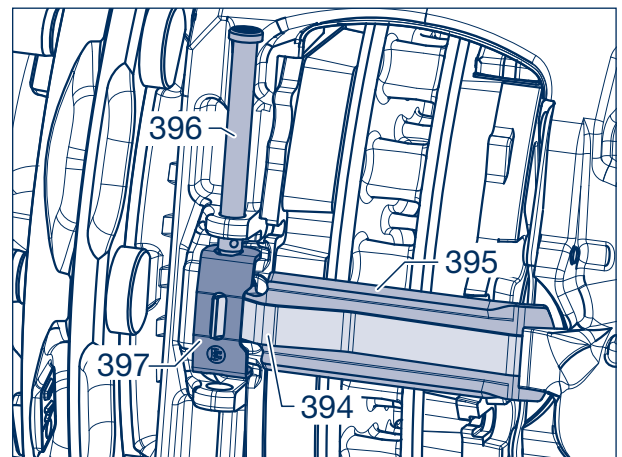

Figure 11

- [20] Insert the bolt (396) from above, and secure it with the spring split pin (398).
- [21] Following this, ensure that the wheel or hub can turn slightly when the brake is released.

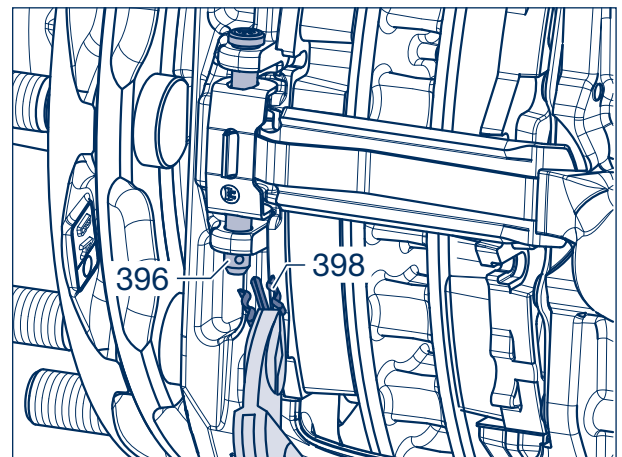

Figure 12

8 Changing the brake linings

8.2 Setting the clearance

- [22] Using a spanner (AF 13), turn the resetter clockwise.
- [23] Advance the brake until the brake linings rest against the brake disc free of play.

Max. torque: 15 Nm



Attention!
Do not use a cordless screwdriver or impact wrench. Using these tools would cause considerable damage!

- [24] Next, turn back the adjuster by 90°.

- [25] Lubricate the entire face of the sealing bush with BPW ECO Disc Grease.

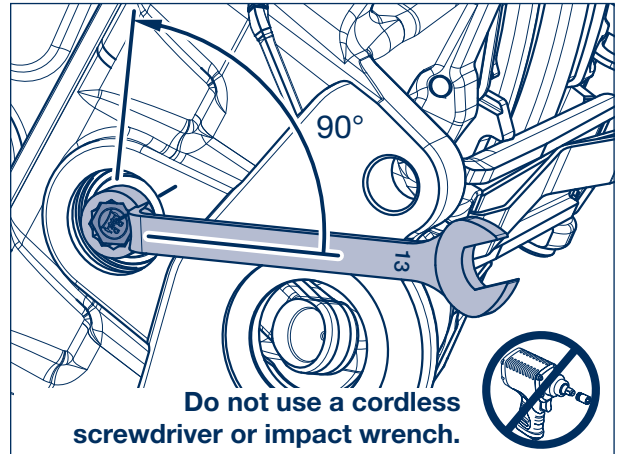

Figure 13

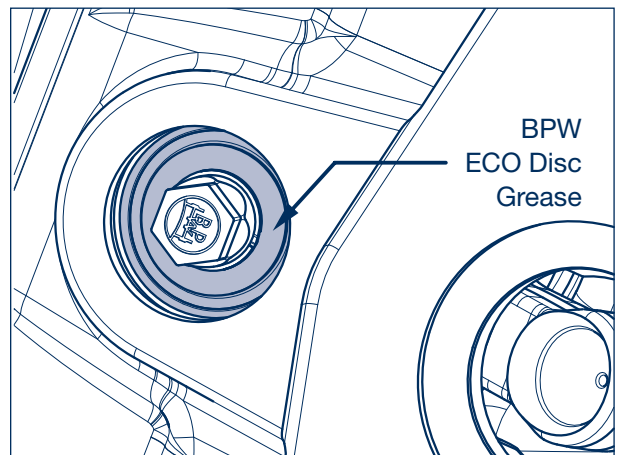

Figure 14

Mounting new cap

- [26] Insert the O-ring (without grease) into the groove of the **new blue cap** if not pre-assembled.
- When using a new black cap, the O-ring is omitted.

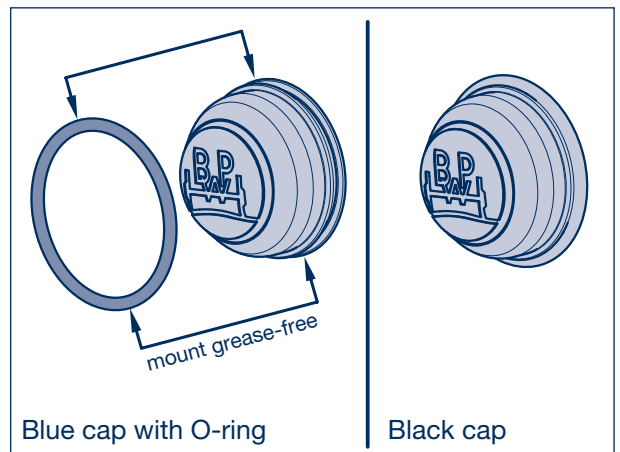

Figure 15

- [27] Lubricate the outside of the O-ring / black cap with BPW ECO Disc Grease.

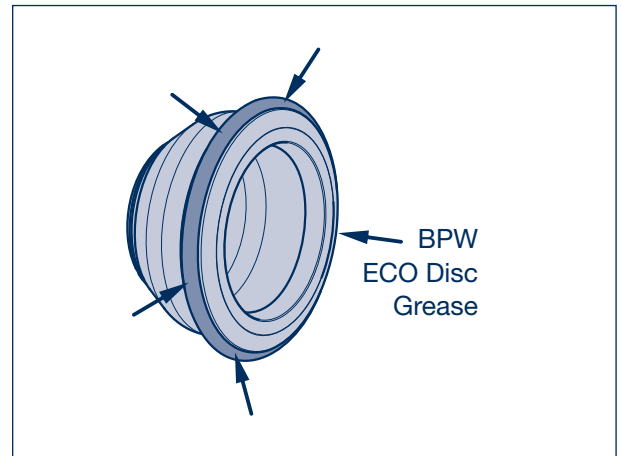

Figure 16

- [28] Place the cap at an angle in the bore groove.

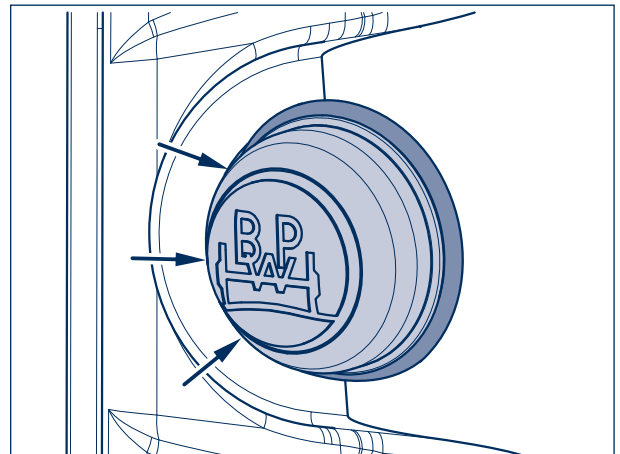

Figure 17

- [29] Insert the cap with sealing lips and O-ring into the cylindrical part of the bore and then press in until the sealing lips with O-ring click in the bore hole groove.

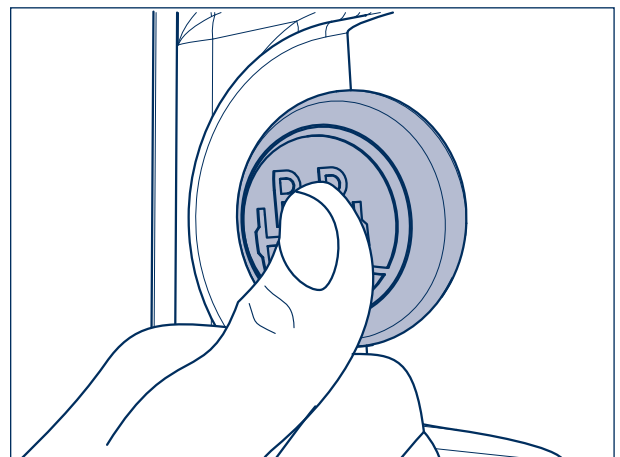

Figure 18

8 Changing the brake linings

- [30] The correct fit is established when the cap is centred in the hole and the O-ring is no longer visible.

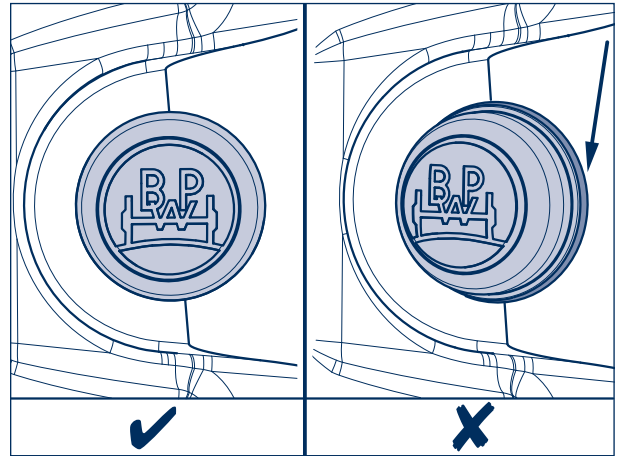

Figure 19

- [31] Install the brake pad wear sensing (702) if it has been removed (see page 41).

- [32] Reattach the wheels.



Repair note!
Only use wheels that have a valve outside the wheel brace.

- [33] Screw on the wheel nuts.

- [34] Lower the axle and tighten the wheel nuts to the required tightening torque.

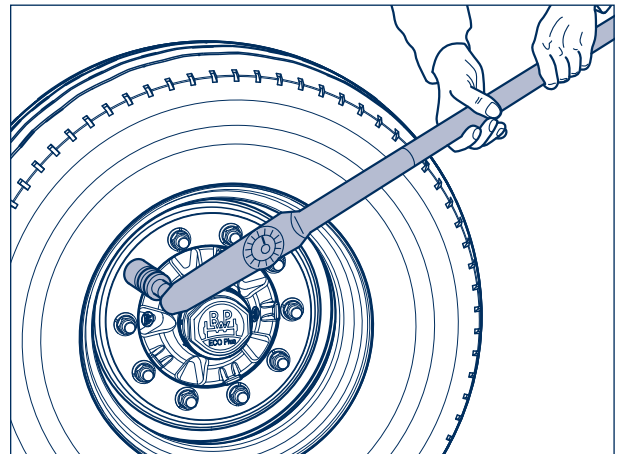

Figure 20



Warning!
The tightening torque of the wheel nuts must be checked after the first run under load conditions. If necessary, retighten them to the prescribed value.



Warning!
New discs and linings only have an optimal braking effect after a few braking operations.
For this reason, run in new brake linings while avoiding lengthy and unnecessarily sharp brake operations.

Brake pad wear sensing, brake lining - dust cover

9

9.1 Disassembly of the brake pad wear sensing

- [1] Prevent the vehicle from rolling away.
- [2] Release the service and parking brake and remove the wheels.
- [3] Remove the sensor connector (702/1) from the support (702/2) and disconnect the cable.

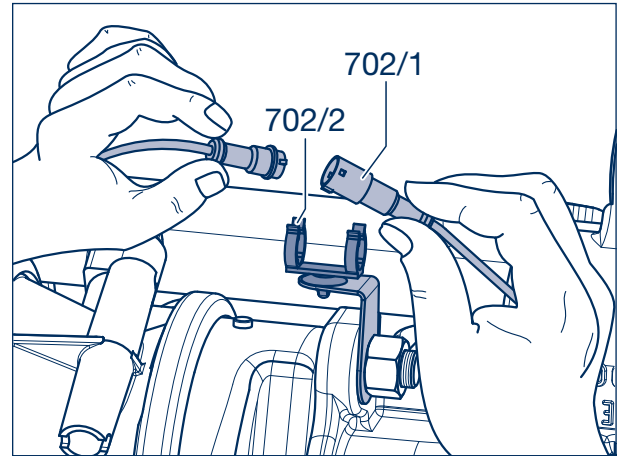

Figure 1

- [4] Disconnect the brake pad wear contacts (arrows) from the brake linings (390).
- [5] Remove the cable ties from the pad retainer holder and, if necessary, from the brake cylinder flange.
- [6] Remove the complete brake pad wear sensing unit (702).

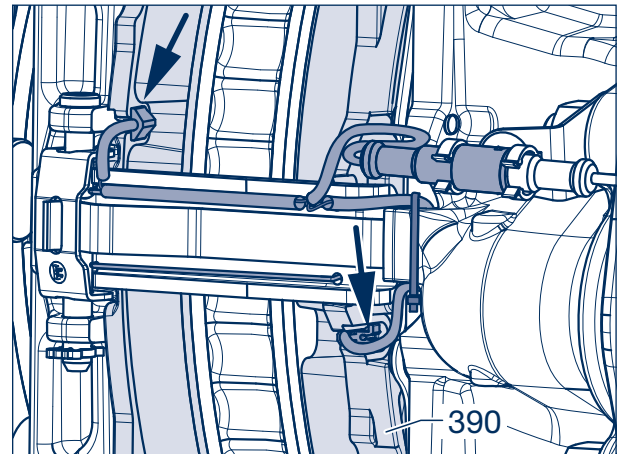

Figure 2

9.2 Installing the brake pad wear sensing

- [7] Pre-mount the retention clip (702/3) in the protective sleeve of the cable as shown in figure 3.

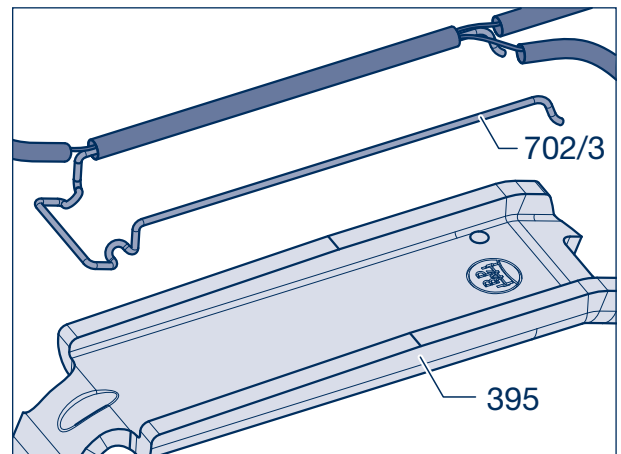

Figure 3

9 Brake pad wear sensing, brake lining - dust cover

- [8] Insert the open end of the retention clip (702/3) into the bore holes in the pad retainer (395) and clip it onto the front mounting bracket.



Repair note!

Ensure the retention clip is firmly seated on the retaining clip!
When mounting the retention clip, make sure that the cables of the wear sensors are not trapped underneath.

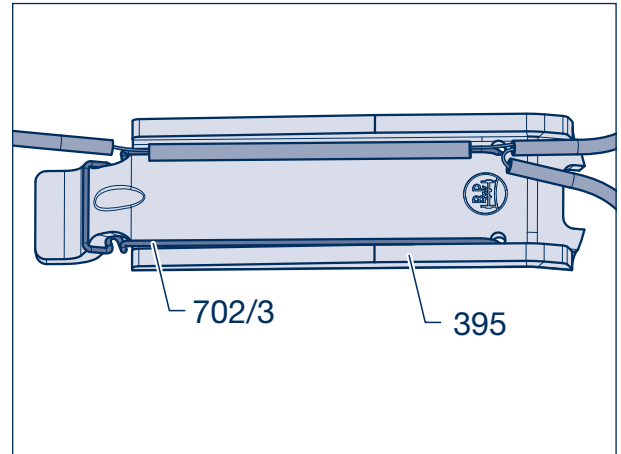

Figure 4

- [9] Mount the pre-assembled pad retainer. A cable must be passed under the pad retainer on the holder on the brake caliper (arrow).



Repair note!

When assembling the clamping spring (394), make sure that the cables of the wear sensors are not trapped underneath.

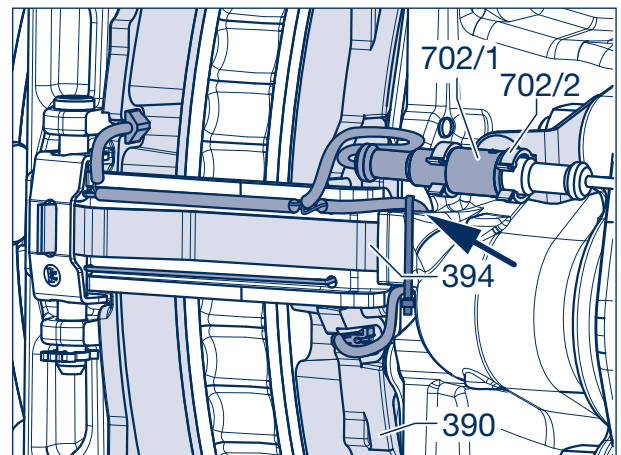

Figure 5

- [10] Clip the brake pad wear contacts into the recesses on the brake linings (390); see also figure 6.
- [11] Fix the cable with a cable tie to the holder for the pad retainer (arrow).
- [12] Clip the sensor connector (702/1) into the support (702/2) or fix the cable to the air hoses with a cable tie in case of attachment without a support.



Repair note!

Cables and angle brackets must be fixed so that there is no contact between wheel or rim.

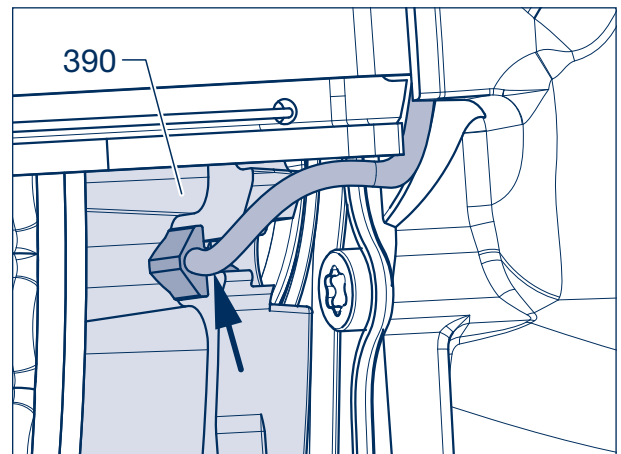

Figure 6

- [13] Connect the cable.

9.3 Brake lining - dust cover

- [1] Prevent the vehicle from rolling away.
- [2] Release the service and parking brake and remove the wheels.
- [3] Pull the spring split pin (398) out of the bolt (396) with a spring plier.

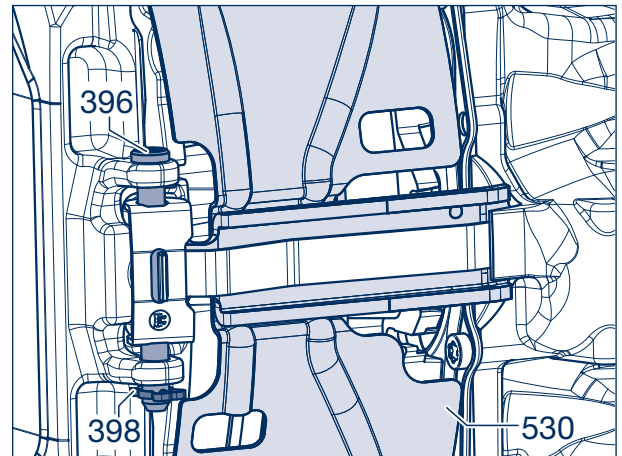

Figure 7

- [4] Depress the clamping spring (394) and remove the bolt (396) with the holding clamp (397).



Caution!
Apply counter pressure to the brake linings or the brake lining - dust cover (590) as required so that they do not fall out of the lining groove during removal.

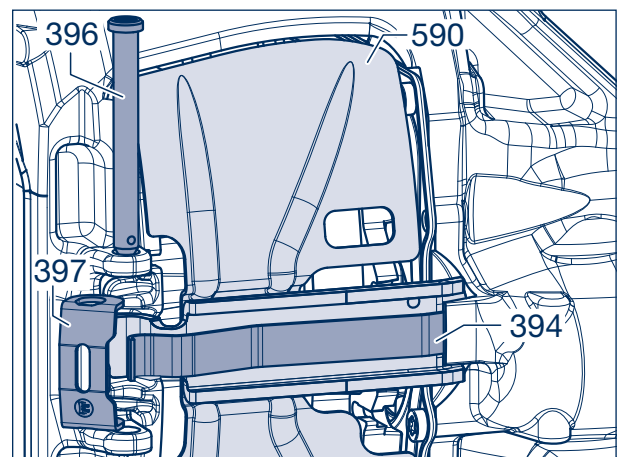



Figure 8

- [5] Remove the clamping spring (394) with the brake lining - dust cover (530).
For versions with separate brake pad retaining clips (395), remove these as well.
-  Install the brake lining - dust cover (530) in reverse order to removal.

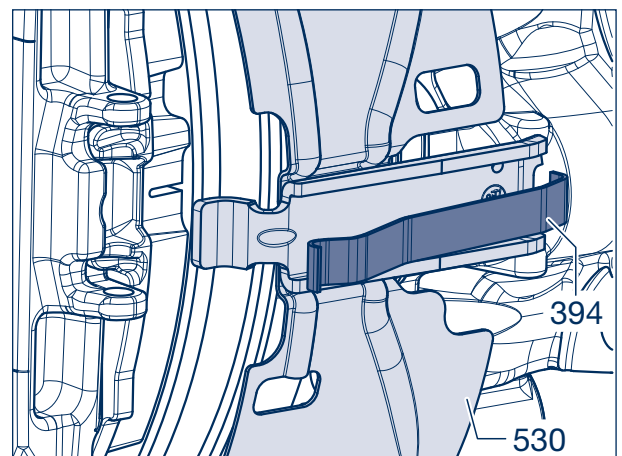

Figure 9

10 Disassembly / assembly of the brake caliper

10.1 Removing the brake caliper

- [1] Remove the brake linings and, if present, remove the wear indicator cable (see chapter 8).
- [2] Remove the brake cylinder (see chapter 13).
- [3] Unscrew the sealing caps of the caliper guide (335) using the adapter (BPW no.: 02.0130.47.10 or 02.0130.49.10, AF 14).



Warning!
Before loosening the cylinder head screws, secure the brake caliper against falling down.

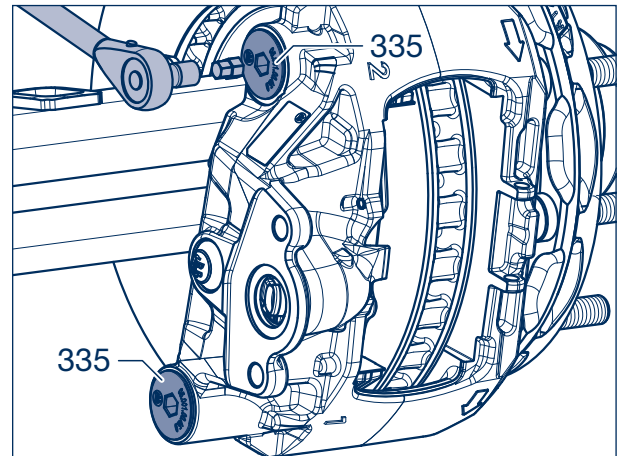

Figure 1

- [4] Unscrew the cylinder head screws (325, 345) with the adapter AF 14 mm, according to the version T12, T14, T17 or T18 (see page 19 and 20).

If there is enough clearance, a ratchet with a box spanner AF 14 can be used.



Caution!
DANGER OF CRUSHING!
Only hold the brake caliper on the outside. Never place fingers between the brake caliper and the brake anchor!
Never attach a lifting device to the pad retainer, since the pad retainer can be damaged.

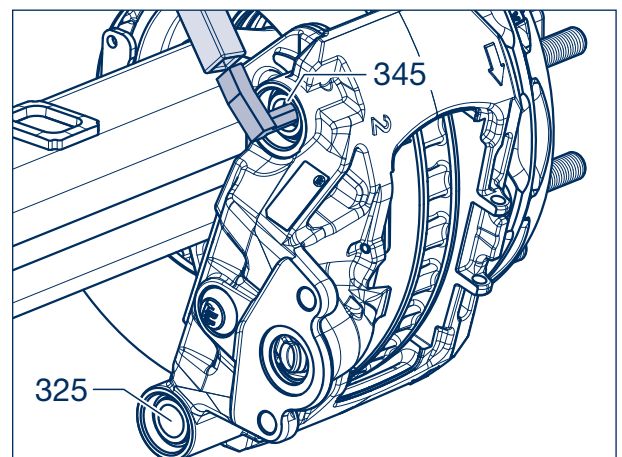

Figure 2



Caution!
DANGER OF INJURY!
The brake caliper must be secured against falling when it is taken down. Use a lifting device or second person for assistance.

- [5] Remove the brake caliper from the caliper anchor plate.



Caution!
DANGER OF ACCIDENT!
Do not open or dismantle a brake caliper.
Only use replacement brake calipers.

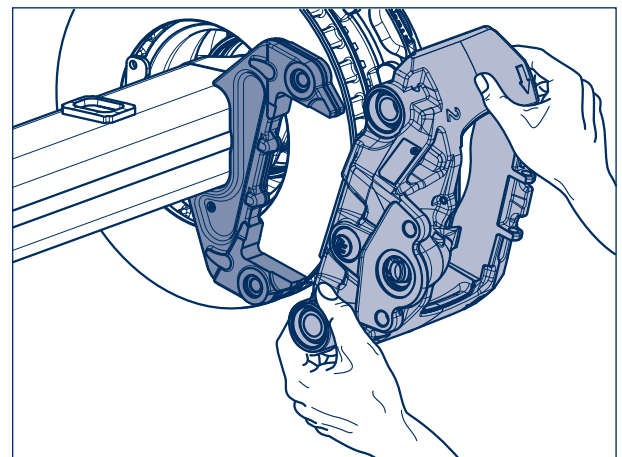

Figure 3

10.2 Installing a brake caliper

 **Continue with step [12] if the brake caliper is to be reused.**

[6] The sealing plugs (arrows) must be removed from the bellows (354) if replacement brake calipers are to be used.

Note: The replacement brake calipers are pregreased with BPW ECO Disc grease.

[7] Unscrew the sealing caps (335).

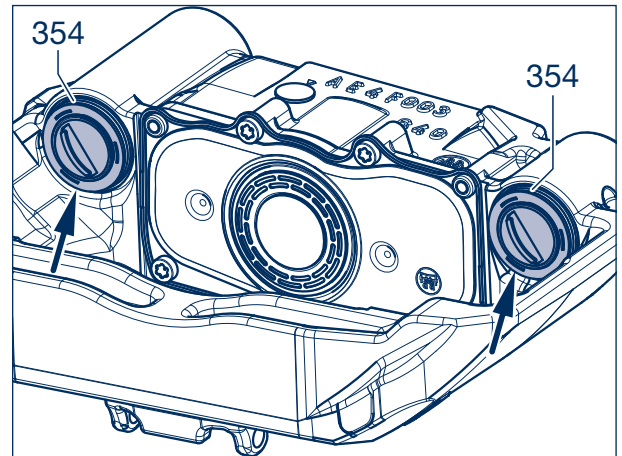

Figure 4

[8] Coat the O-ring (355) with BPW ECO Disc Grease and insert it into the groove (arrow) of the floating guide pin.

[9] Install the guide pins (326, 346).

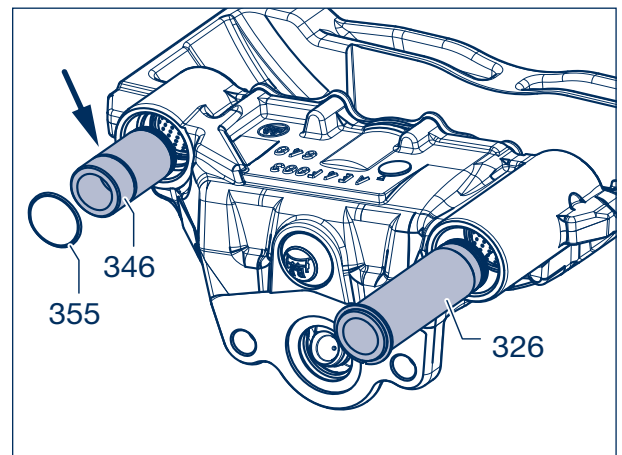

Figure 5

[10] Insert the bellows (354) into the groove on the guide pins (326, 346, arrow).

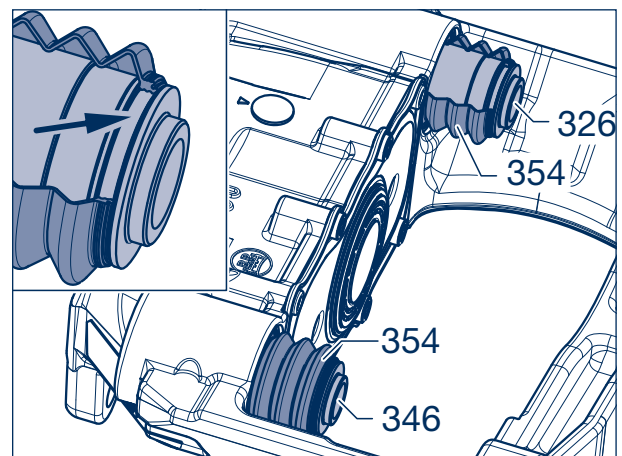

Figure 6

10 Disassembly / assembly of the brake caliper

- [11] Secure the bellow (354) in the groove of the guide pins (326, 346) by pushing on the ring (356).



Note:

Check the guide pins (326, 346) for ease of movement before installing the brake.

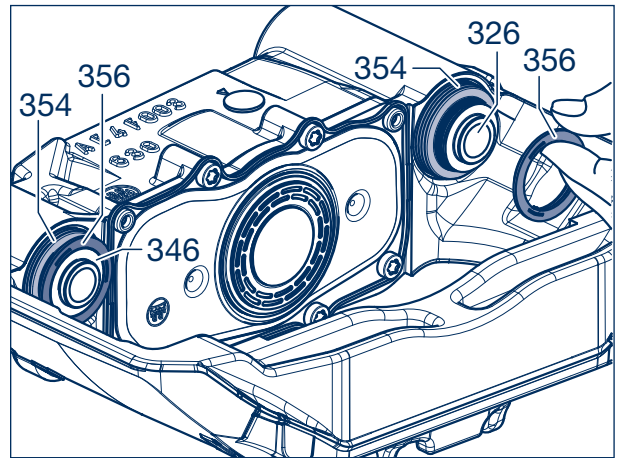

Figure 7

- [12] Place the brake caliper on the brake anchor. Observe the left-hand and right-hand version. The arrow on the brake caliper shows the direction of the wheel rotation.



Repair note!

When placing the brake caliper, ensure that the bellows (354) have sufficient clearance in order to prevent damage.

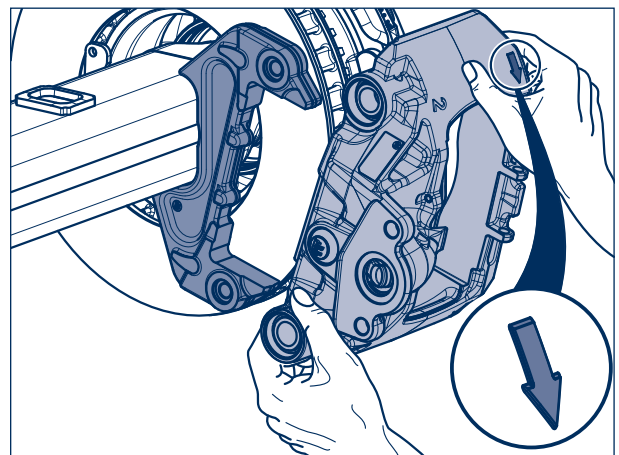

Figure 8



Repair note!

Ensure that the bellow (354) and the ring (356) are seated properly on the guide pin when mounting the brake caliper.

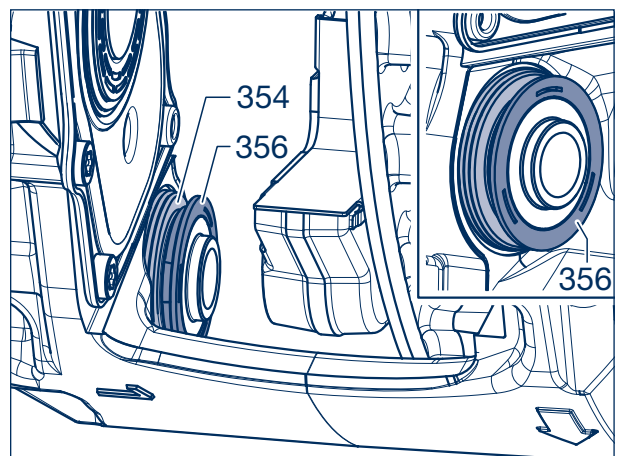

Figure 9



Caution!
Cylinder head screws (325, 345) must not be re-used!

- [13] Apply BPW ECO Disc Grease to the new cylinder head screws (325, 345) on the thread and the screw seating.
- [14] Using an adapter AF 14, screw in according to version T12, T14, T17 or T18 (see page 18 and 19), and **do not tighten!**

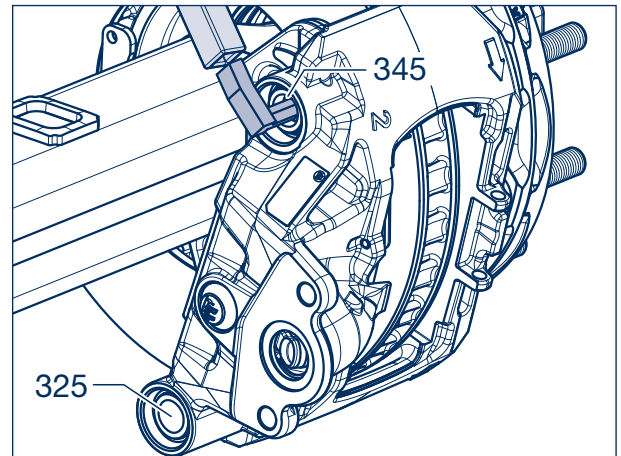

Figure 10



Repair note!
For the brake function, it is essential to tighten the fixed bearing bolt (marking 1 on the brake caliper) to the required tightening torque first.

- [15] Tighten the cylinder head screw of the fixed bearing (325) with a tightening torque of:
M = **260 Nm** (250 - 270 Nm)
or otherwise with
150 Nm + 180° rotation angle.

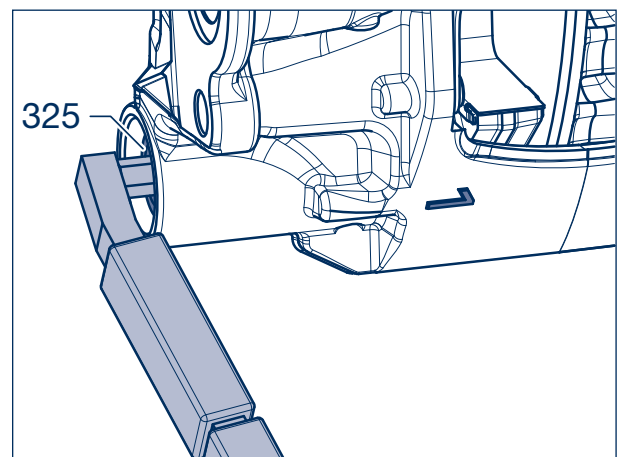

Figure 11

- [16] Tighten the cylinder head screw (345) of the floating bearing (marking 2 on the brake caliper) with a tightening torque of:
M = **260 Nm** (250 - 270 Nm)
or otherwise with
150 Nm + 180° rotation angle.

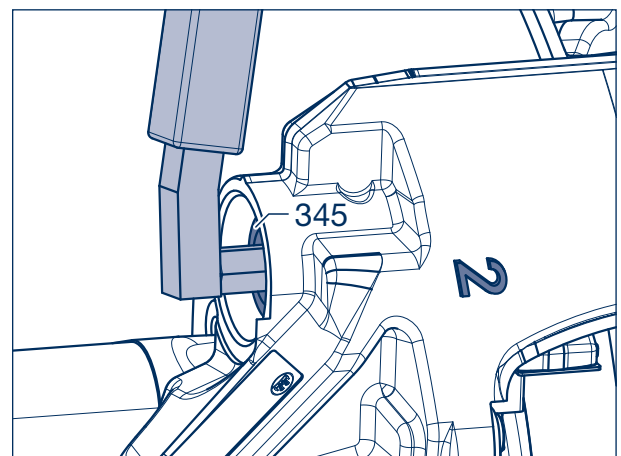

Figure 12

10 Disassembly / assembly of the brake caliper

- [17] Push the new O-ring (336) onto a new sealing cap (335) until contact (arrow).
- [18] Screw in new pre-assembled sealing caps for the caliper guide (335, 336) using the adapter (BPW no.: 02.0130.47.10 or 02.0130.49.10, AF 14). For this purpose, center the brake caliper in relation to the brake disc.
Tightening torque:
15 Nm (15 - 20 Nm)
- [19] Check that the brake caliper can be moved easily.
- [20] Install the brake linings; see chapter 8.
- [21] Check the adjustment (not required with replacement brake calipers) and adjust the clearance; see also 4 page 28:

1. Remove the sealing cap (370).
2. Turn the resetter with a spanner (AF 13) 90° **counterclockwise**.
Max. reset moment: 15 Nm
3. Actuate the brake 5 to 10 times with approx. 2 bar.
4. When the sliding caliper is forcefully pushed in the direction of the axle, it must now be possible to move the sliding caliper by the clearance of 0.7 - 1.6 mm.
If the clearance is correctly set, the adjustment is OK.
5. A new seal cap (vented) must be used. Squeeze it and press it into the brake caliper (follow the instructions in chapter 8.2, Changing brake linings, on page 38 of the installation instructions).



Warning:
If the instructions are not followed properly and the cap is not fitted correctly, there is a risk of moisture getting into the brake and corroding the adjuster. This can reduce the braking effect or even cause it to fail completely.



Note!
When new brake calipers are used, the plug must be removed! Using a thin screwdriver, pierce the plug in the middle and lever the cap out of the brake caliper.

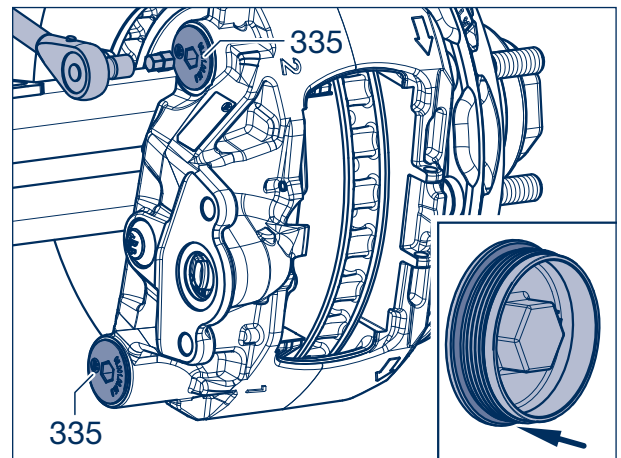

Figure 11

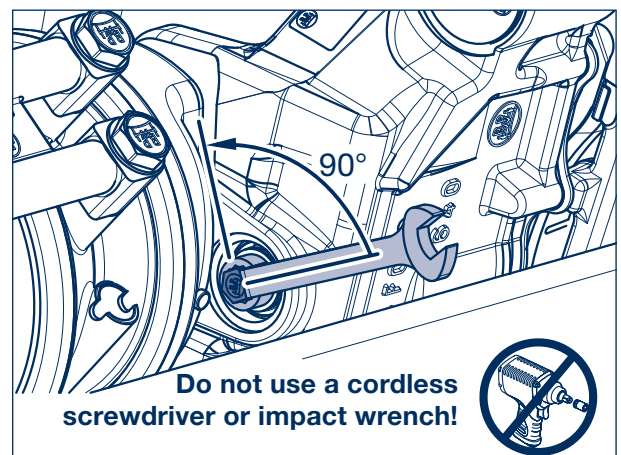

Figure 12

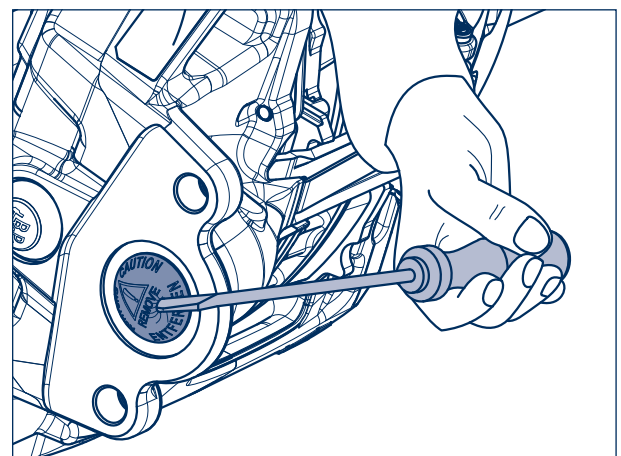

Figure 13

- [22] Fit the membrane or spring brake cylinder (see chapter 13.3 or 13.4).

Changing the bellow with pressure plate 11



Note!

The inside of the brake caliper is exposed when the bellows are replaced. Do not allow dirt or moisture to enter this area. Clean the brake caliper beforehand if necessary.

- [1] Reset the bellow with pressure plate and remove the brake linings, see chapter 8.
- [2] Use a screwdriver to lift out and remove the bellow with pressure plate (363) from the dust cover. Do not deform the dust cover while doing so.



Repair note!

The bellow with pressure plate (363) must be removed completely from the seat in the brake caliper. If the bellow has been torn off during disassembly, remove the remnants from the seat.



Repair note!

The bellow must be free of damage and be dry and free of contamination on the inner side. Otherwise, the brake caliper must be replaced.

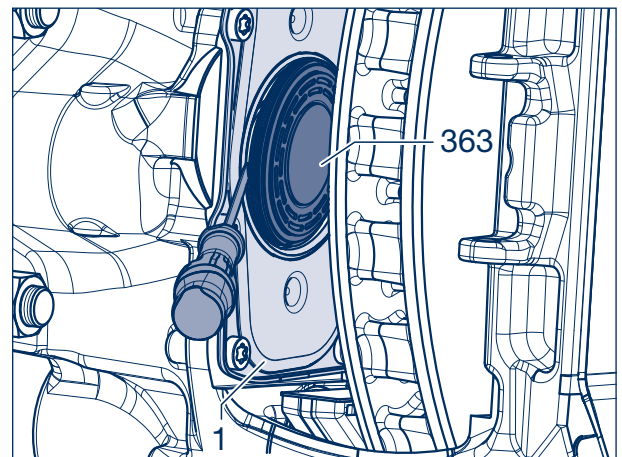

Figure 1

- [3] Screw in all components (T22, T23, and T24) of the assembly tool (BPW no. 05.001.00.79.0) up to the end stop.

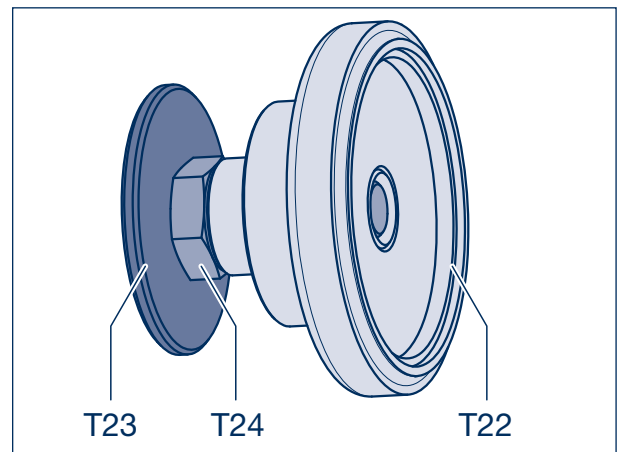

Figure 2

11 Changing the bellow with pressure plate

- [4] Insert a new bellow with pressure plate (363) into the piston (T22) of the assembly tool (rubber bellow points outwards).

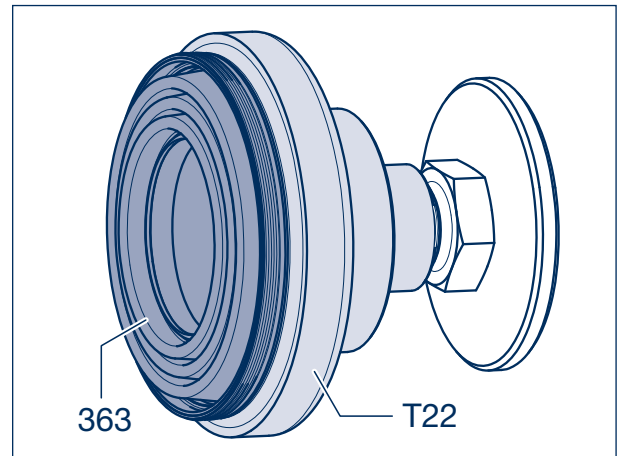

Figure 3

Bellow assembly with an installed brake

- [5] Push the brake caliper as far as possible in the direction of the centre of the axle. Insert the assembly tool with bellow (363) between the brake disc (380) and the dust cover.
- [6] Center the bellow in the holder in the dust cover.
- [7] Unscrew the spacer (T24) of the assembly tool in a counterclockwise direction until it makes contact with the brake disc.

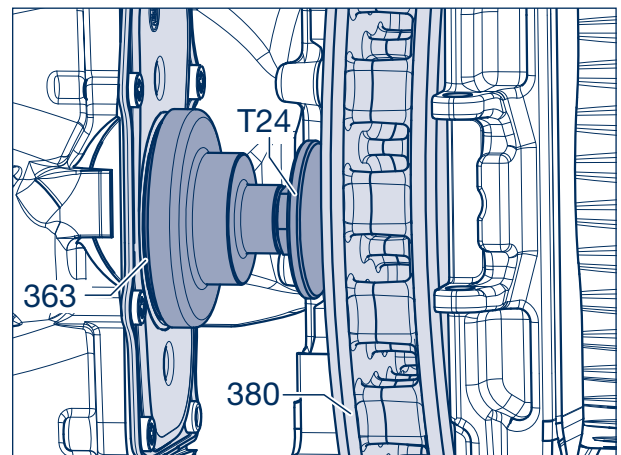

Figure 4

Bellow assembly with the brake removed

- [5] Insert the assembly tool with bellow (363) into the brake caliper.
- [6] Center the bellow in the holder in the dust cover.
- [7] Slightly unscrew the spacer (T24) from the piston (T22) and the screw (T23) from the spacer, and use the opposite side of the brake lining shaft as a stop for pressing in.

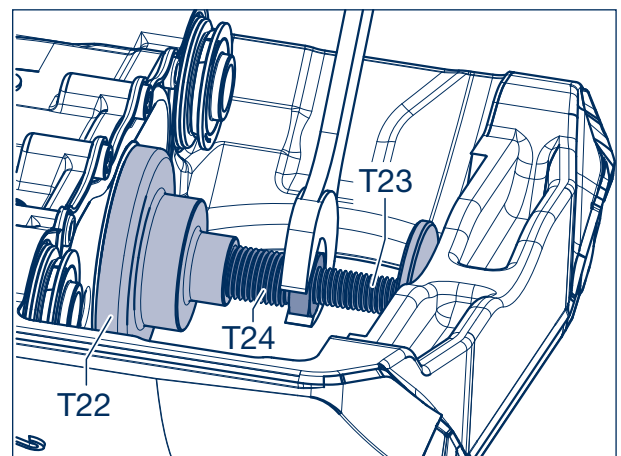

Figure 5

- [8] Use a spanner AF 24 to unscrew the spacer and press in the bellow until it stops.



Repair note!

The grooved bellow seat must be completely assembled in the dust cover, the gap between the piston and the bead of the dust cover is < 0.7 mm (arrow). Make sure that the seating is entirely straight.

- [9] Screw in the spacer and remove the assembly tool.
- [10] Fit the brake linings and adjust the clearance; see chapter 8.

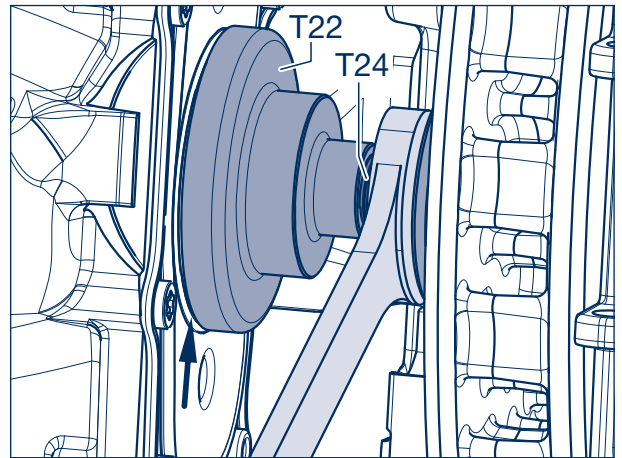

Figure 6

12 Overhauling the brake caliper guide

12.1 Replacing the bellow (fixed and floating bearing)

- [1] Dismantle the brake caliper, see chapter 10.
- [2] Remove the rings (356) from the guide pins (326, 346) or bellows (354).

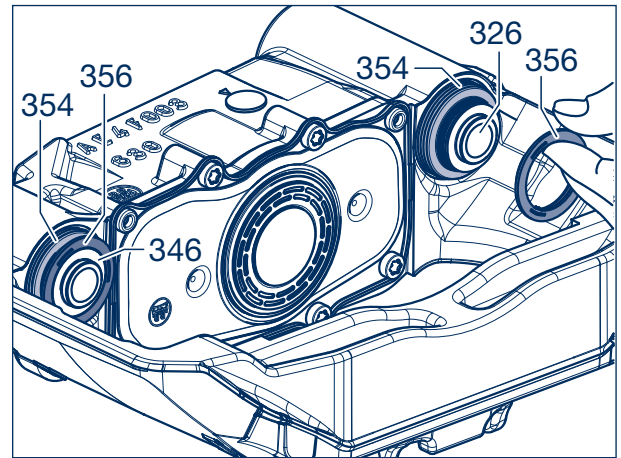

Figure 1

- [3] Pull out the guide pins (326, 346).

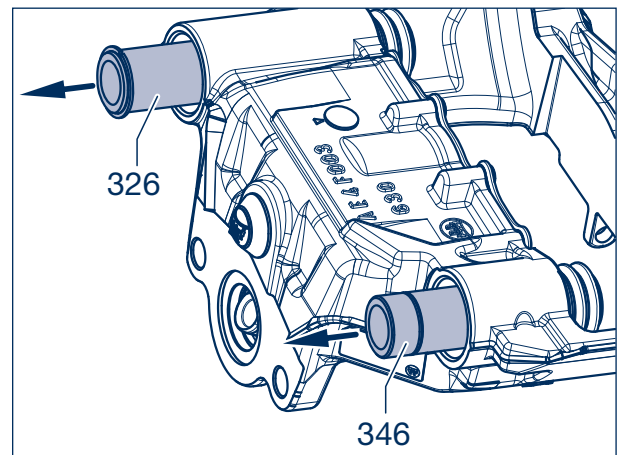

Figure 2

- [4] Lever out the bellows (354) with a screwdriver.



Repair note!
The seal seats of the bellows (354) in the brake caliper must not be damaged.

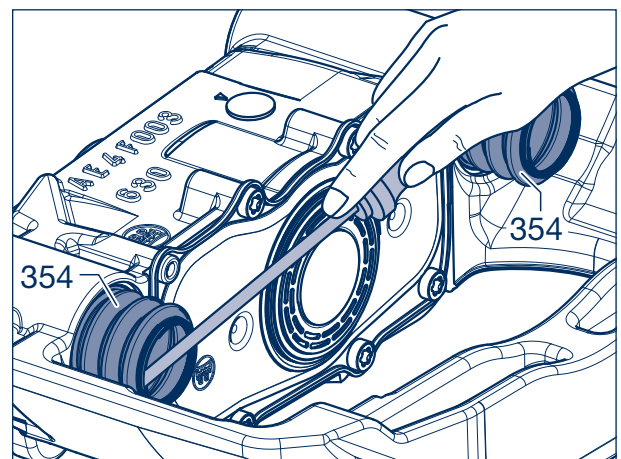



Figure 3

- [5] Check the seal seats in the brake caliper and the guide bushes (328, 348) for corrosion, dirt and damage, and replace them if necessary.

 For installation of the bellows, see page 56, starting from working step [34].

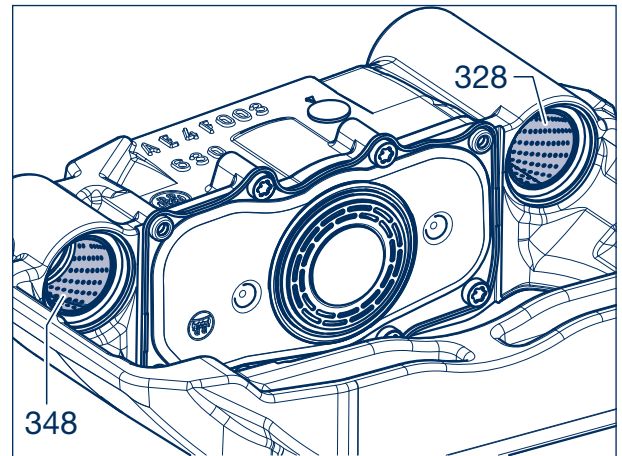

Figure 4

12.2 Replacing the guide bushes

- [6] To prevent accidents, position the brake caliper in a vice and fasten it to the outer bar. Ensure that the contact surfaces of the brake linings do not become damaged and use braces if necessary.
- [7] Clean the contact surfaces for the insertion / removal tool and the guide bushes (328, 348).

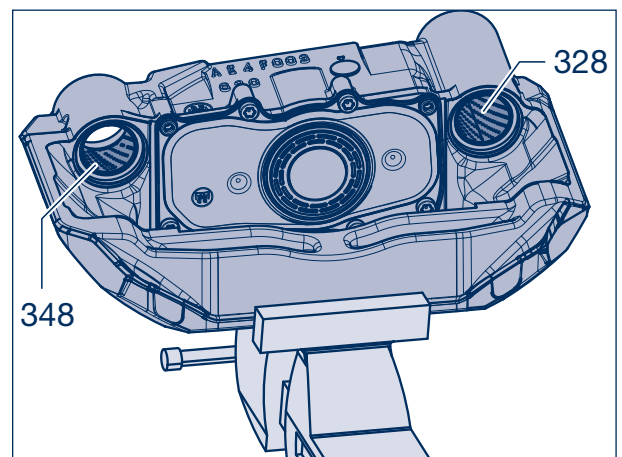

Figure 5

Floating bearing 2 (short guide pin)

Extraction

- [8] Slide the ball bearing (T2) and the sleeve (T3) onto the threaded spindle (T1).
- [9] Guide the tool into the bearing from the outer side.

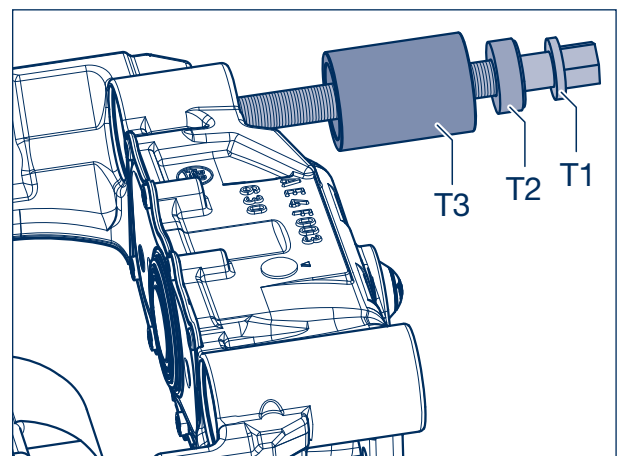

Figure 6

12 Overhauling the brake caliper guide

- [10] Connect the extraction tool (T4) and insert it into the guide bush (348).
- [11] Screw on the nut (T6) up to the stop point.
- [12] Turn the threaded spindle (T1) to pull the guide bush (348) out of the bearing. If necessary, brace the nut (T6) with an AF 32 spanner.
- [13] Clean the bearing seats.



Repair note!
The bearing bore must be clean and free of grease.

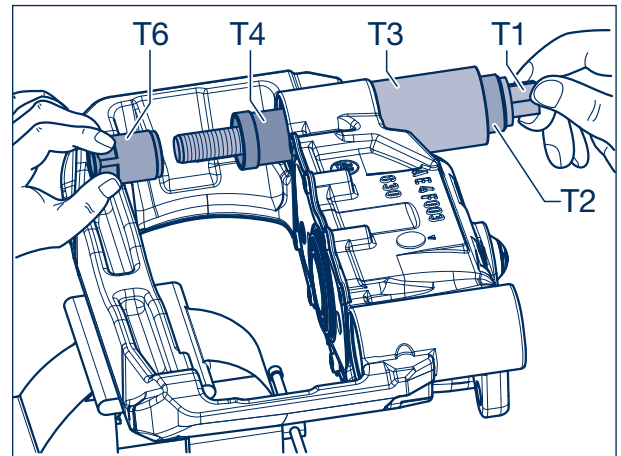

Figure 7

Fixed bearing 1 (long guide pin)

Extraction

- [14] Slide the ball bearing (T2) and the sleeve (T3) onto the threaded spindle (T1).
- [15] Guide the tool into the bearing from the outside.

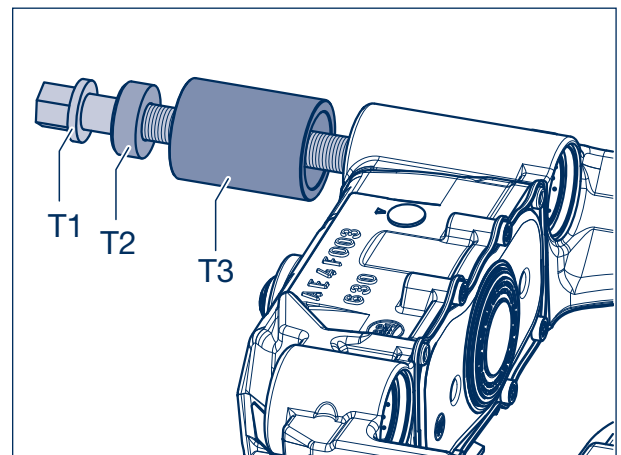

Figure 8

- [16] Connect the extraction tool (T4) and push it into the guide bush (328).
- [17] Screw on the nut (T6) up to the stop point.
- [18] Turn the threaded spindle (T1) to pull the guide bush (328) out of the bearing. If necessary, brace the nut (T6) with an AF 32 spanner.
- [19] Clean the bearing seats.



Repair note!
The bearing bore must be clean and free of grease.

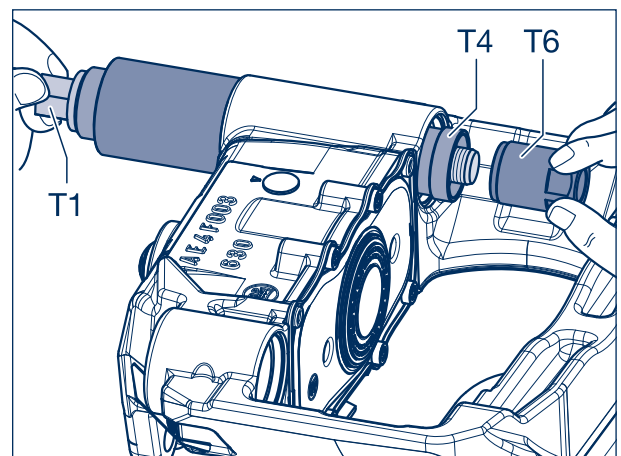

Figure 9

Floating bearing 2 (short guide pin)

Pressing in

- [20] Slide the ball bearing (T2), the extraction tool (T4), and the pressing tool for the floating bearing (T21) onto the threaded spindle (T1).
- [21] Slide the new guide bush (348) onto the pressing tool (T21) for the floating bearing.
- [22] Insert the tool into the bore hole for the guide bush.

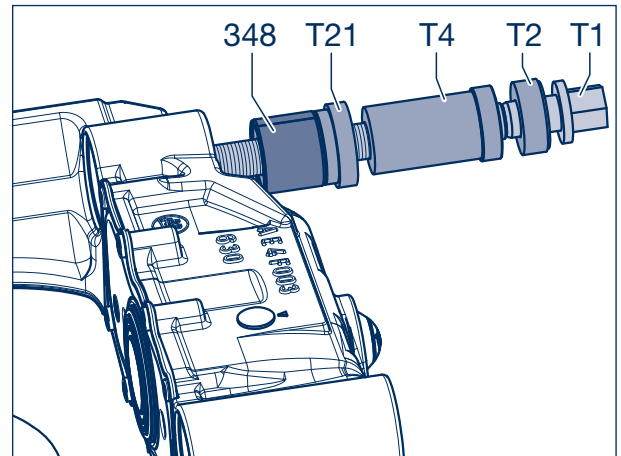

Figure 10

- [23] Slide the retraction plate (T20) onto the threaded spindle (T1) until it makes contact with the brake caliper. The chamfer must be guided into the bore hole on the brake caliper and the contact surface must lie flat.
- [24] Screw on the nut (T6) while ensuring that the retraction plate (T20) is properly seated.
- [25] Turn the threaded spindle (T1) up to the stop point to pull the guide bush (348) into the bore hole. If necessary, brace the nut (T6) with an AF 32 spanner.
- [26] Unscrew the nut (T6) and remove the tool.

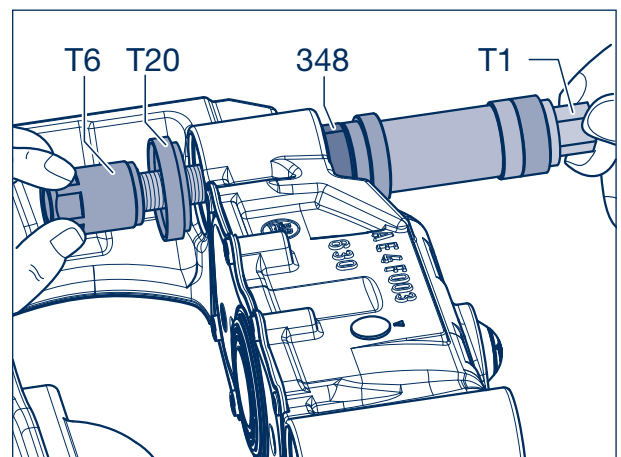

Figure 11

Fixed bearing 1 (long guide pin)

Pressing in

- [27] Slide the ball bearing (T2) and the pressing tool for the fixed guide pin (T8) onto the threaded spindle (T1).
- [28] Push the new guide bush (328) in the correct position onto the pressing tool for the fixed bearing (T8).
- [29] Insert the tool into the bore hole for the guide bush.

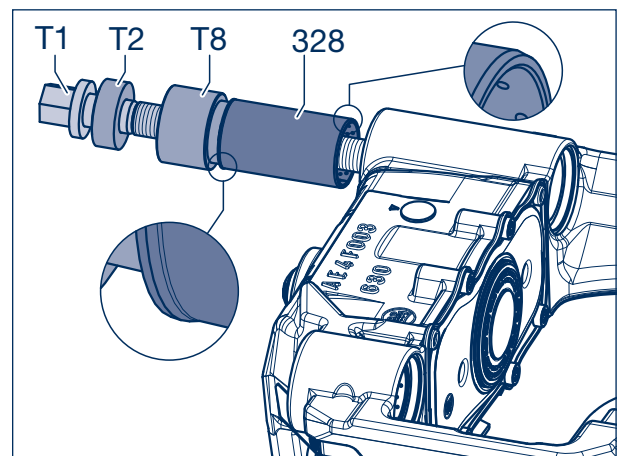

Figure 12

12 Overhauling the brake caliper guide

- [30] Slide the retraction plate (T20) onto the threaded spindle (T1) up to the brake caliper. The chamfer must be guided into the bore hole on the brake caliper and contact with a flush fit.
- [31] Screw on the nut (T6) while ensuring that the retraction plate (T20) is properly seated.
- [32] Turn the threaded spindle (T1) up to the stop point to pull the guide bush (328) into the bearing. If necessary, brace the nut (T6) with an AF 32 spanner.
- [33] Unscrew the nut (T6) and remove the tool.

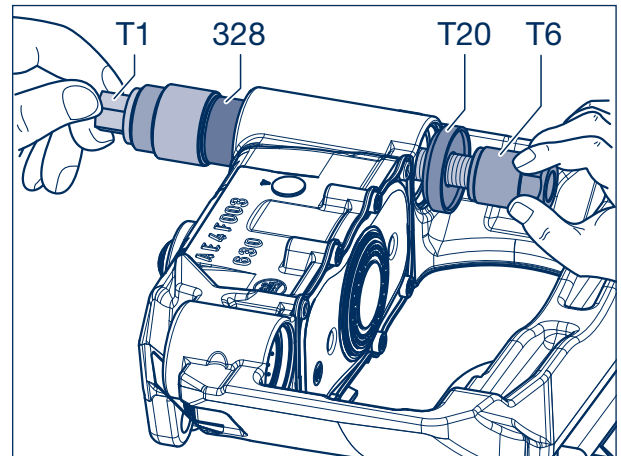

Figure 13

- [34] Insert the new bellows (354) and press them all the way into the caliper housing.



Repair note!
The bellow seat in the brake caliper must be clean and free from grease.

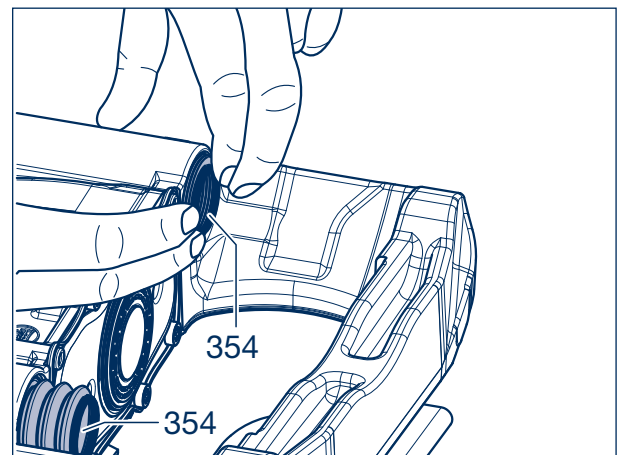

Figure 14

- [35] Make sure the bellows (354) are correctly seated. Pull to test.

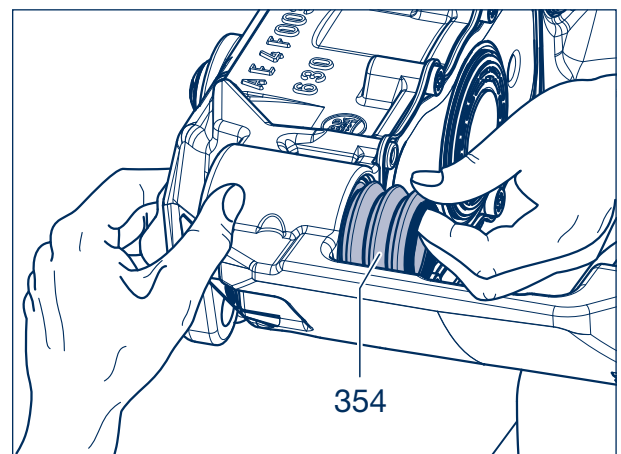

Figure 15

- [36] Insert an O-ring (355) into the groove (arrow) of the floating guide pin.
- [37] Apply **BPW ECO Disc Grease** to the guide bushes (328, 348) and O-ring (355).
- [38] Install the guide pins (326, 346).

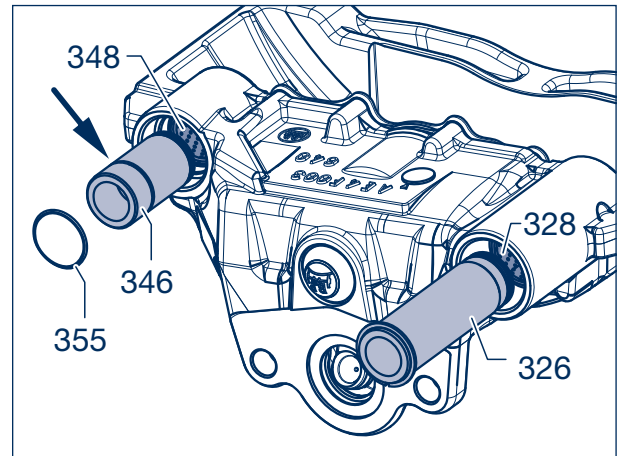

Figure 16

- [39] Insert the bellows (354) into the groove in the guide pins (326, 346, arrow).

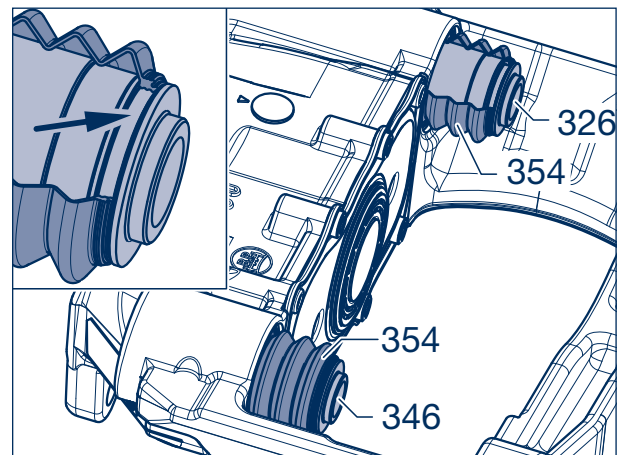

Figure 17

- [40] Push on the ring (356) to secure the bellow (354) in the groove of the guide pins (326, 346).

**Note!**

Check the guide pins (326, 346) for ease of movement before installing the brake.

- [41] Install the brake caliper (see chapter 10.2).

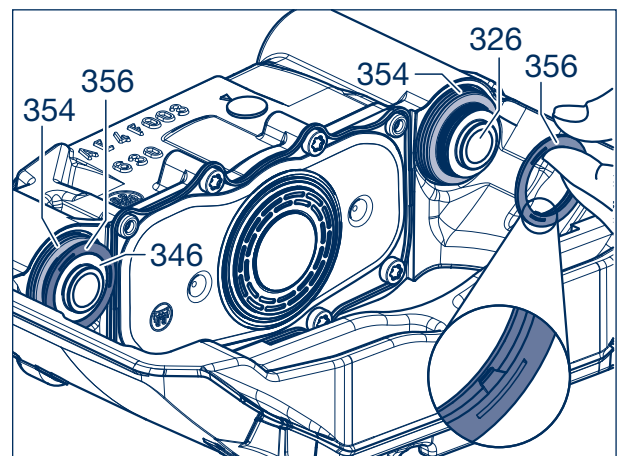

Figure 18

13 Disassembling / assembling the brake cylinders

13.1 Removing the diaphragm cylinder

- [1] Ensure that the brake cylinder (410) is depressurised.
- [2] Unscrew the air connection from the brake cylinder (410).
- [3] Loosen both attachment nuts M 16 x 1.5 - AF 24 on the brake housing.
- [4] Remove the brake cylinder (410).

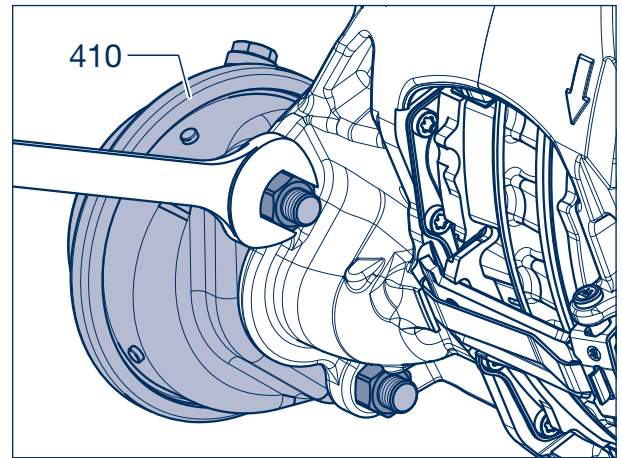

Figure 1

13.2 Assembling the diaphragm cylinder



Note!

Clean the housing and brake cylinder contact surfaces before fitting. The seal (1) and push rod chamber (2) of the brake cylinder (410) must be free of dirt and moisture.

If the brake calipers are leaking, check the brake cylinders for damage. Damaged brake cylinders must be replaced.



Repair note!

Use only brake cylinders that are approved for disc brakes (with "inner sealing")!
(See BPW-TE 2342.0)

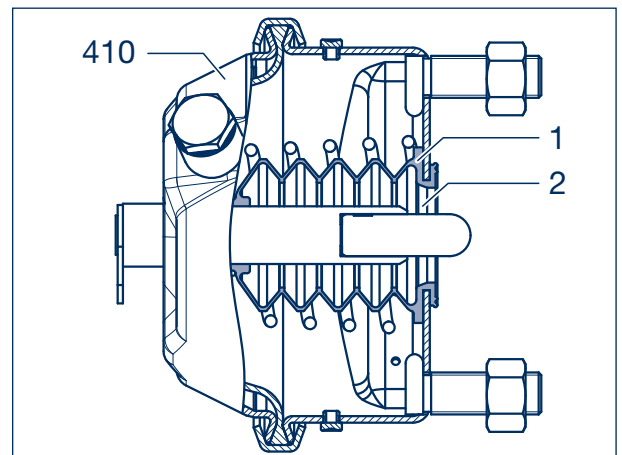

Figure 2

- [5] Before fitting the new brake cylinder (410), grease the spherical cap in the lever (arrow) with **BPW ECO Disc Grease**.



Repair note!

Do not use grease containing molybdenum disulphide!

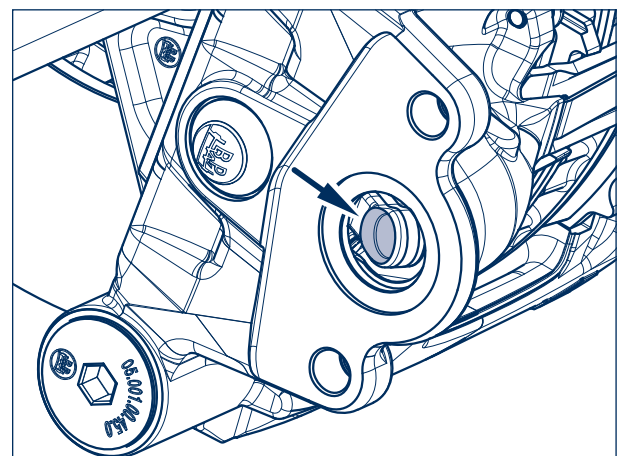

Figure 3

**Note!**

When new brake calipers are used, the plug must be removed! Using a thin screwdriver, pierce the plug in the middle and lever the cap out of the brake caliper.

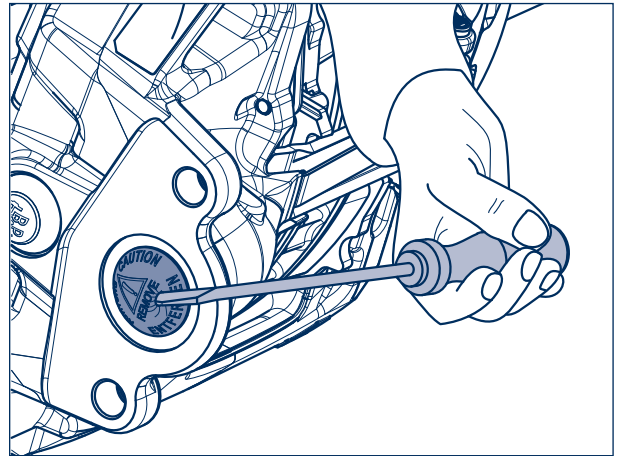

Figure 4

**Caution!**

Only pressurise the brake cylinder (410) when it is mounted on the brake!

- [6] Remove the plug (figure. 4/arrow) for venting from the downwards-pointing bore hole in the new brake cylinder (410).
- [7] All other vent holes must remain sealed!

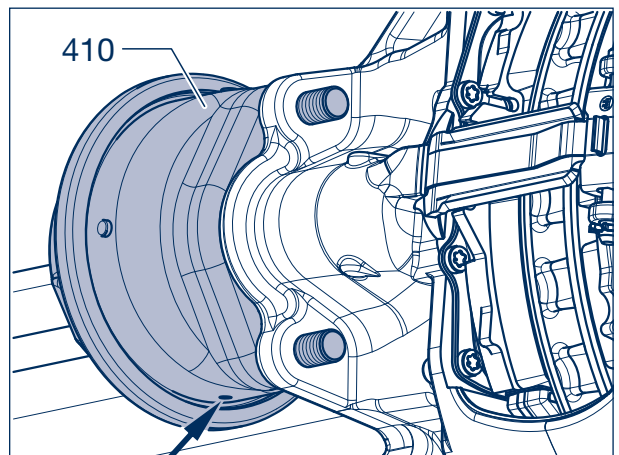

Figure 5

- [8] Position the brake cylinder (410) and install it using new attachment nuts.
Tightening torque:
M 16 x 1.5 - AF 24 M = **180 Nm** (180 - 210 Nm)
- [9] Connect the brake line (air connection) and check the sealing. The brake lines must be routed such that they do not twist or can rub against other components.

**Repair note!**

When connecting the compressed air lines to the brake cylinder, make sure the movement of the brake caliper is not obstructed by any adjacent components.

**Repair note!**

Check the functioning and effectiveness of the brake system!

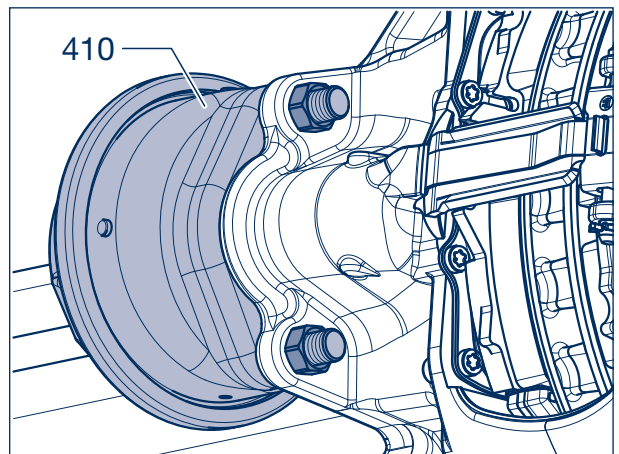

Figure 6

13 Disassembling / assembling the brake cylinders

13.3 Disassembling the spring brake cylinders



Warning!
Before loosening the spring brake cylinders, secure the vehicle against rolling away.

- [1] Release the parking brake (hand brake valve).
- [2] Remove the lock (1) from the bore hole.

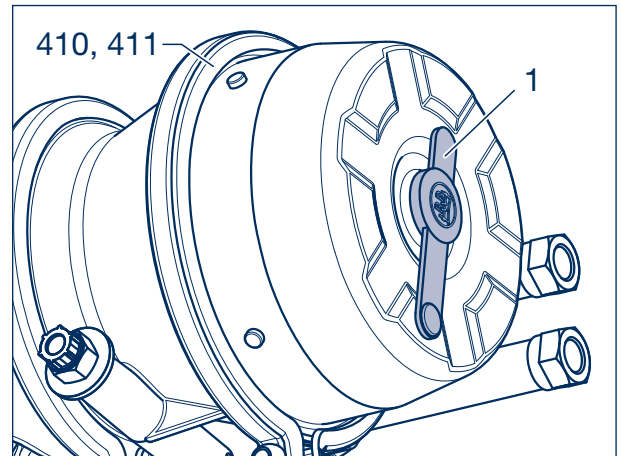

Figure 7

- [3] Remove the protective cap with thread (2), unscrew the nut (3) from the spindle (4) and remove it with the washer (5).

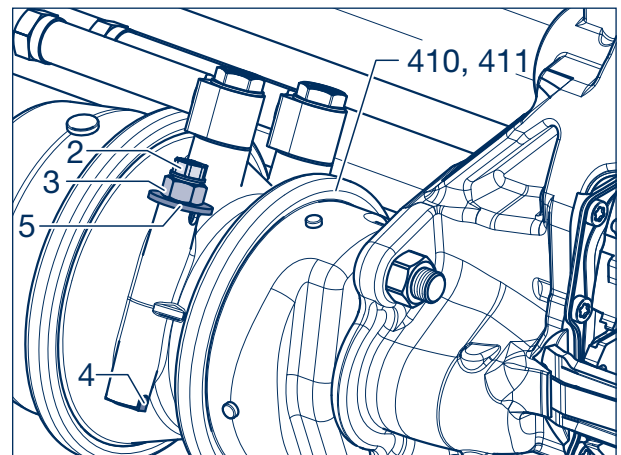

Figure 8

- [4] Insert the threaded spindle (4) into the brake cylinder (410, 411) and turn it 90° to engage.
- [5] Screw on the nut (3) and a washer (5). Tightening the nut causes the brake cylinder to be mechanically released.

In other versions, unscrew and remove the spring brake bolt (mechanical release device / arrow) by turning it counterclockwise.



Warning!
DANGER OF INJURY!
Do not use an impact wrench.
Brake cylinders must not be opened.

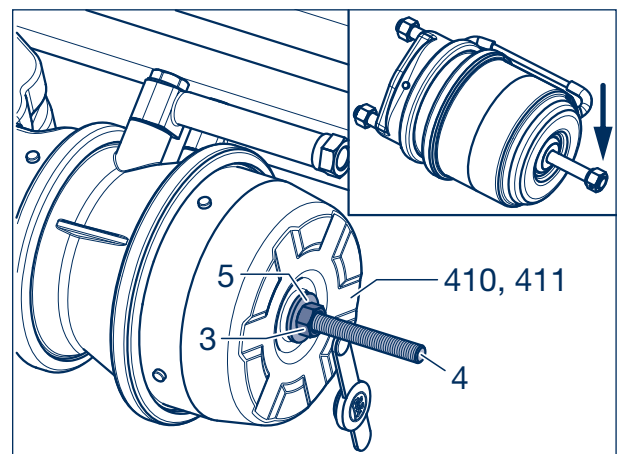

Figure 9

- [6] Mark air connections for proper installation and unscrew them from the brake cylinder (410, 411).
- [7] Loosen both attachment nuts (6) M 16 x 1.5 - AF 24 on the housing of the brake.
- [8] Remove the brake cylinder (410, 411).

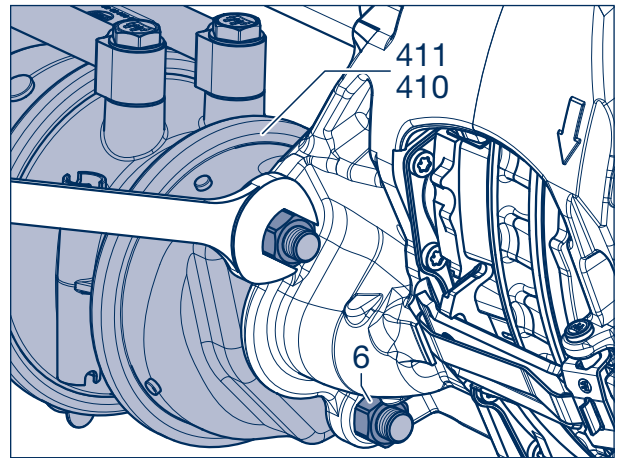

Figure 10

13.4 Assembling the spring brake cylinder



Caution!

Only vent the spring brake cylinder at connection 1.1. (service brake) when it is mounted on the brake!



Note!

When new brake calipers are used, the plug must be removed! Using a thin screwdriver, pierce the plug in the middle and lever the cap out of the brake caliper.

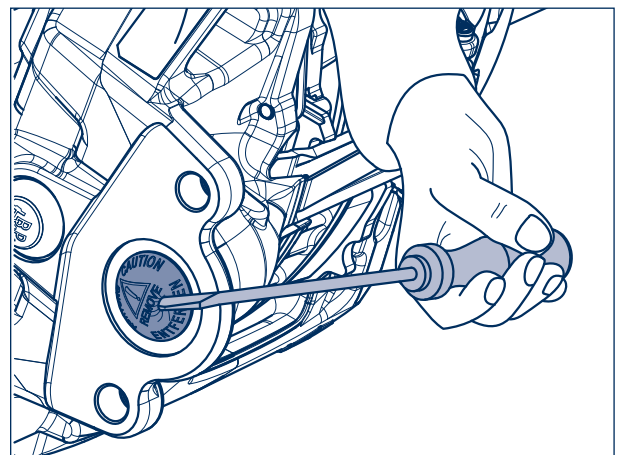

Figure 11



Note!

Clean the housing and brake cylinder contact surfaces before fitting. The seal (1) and push rod chamber (2) of the brake cylinder (410, 411) must be free of dirt and moisture.

If the brake calipers are leaking, check the brake cylinders for damage. Damaged brake cylinders must be replaced!

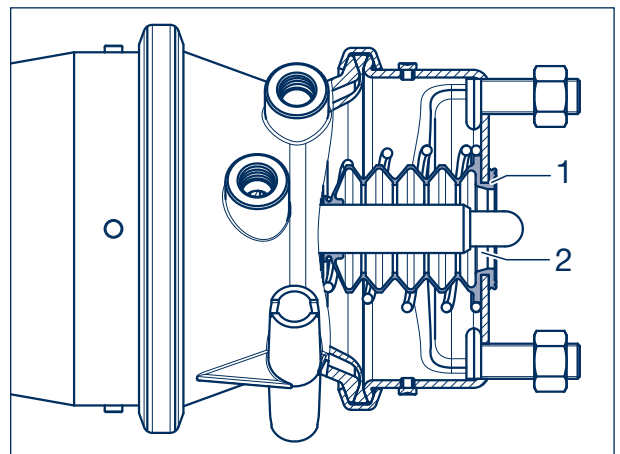

Figure 12



Repair note!

Use only brake cylinders that are approved for disc brakes (with "inner sealing")!
(See BPW-TE 2342.0)

13 Disassembling / assembling the brake cylinders

- [9] Before inserting the new brake cylinder (410, 411), grease the spherical cap in the lever (arrow) with **BPW ECO Disc Grease**.



Repair note!
Do not use grease containing molybdenum disulphide!

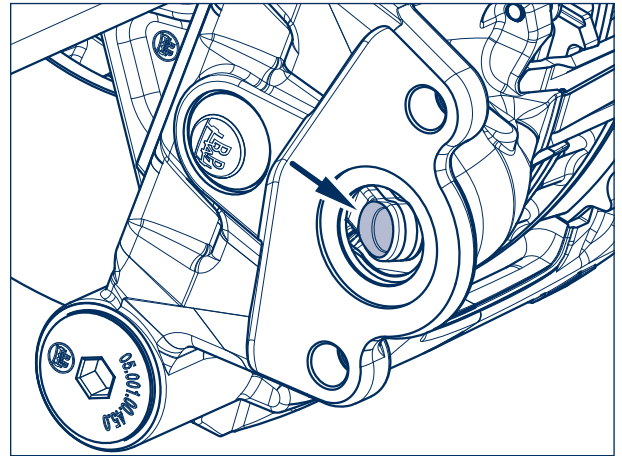

Figure 13

- [10] Position the brake cylinder (410, 411) and install it using new attachment nuts (6).
Tightening torque:
M 16 x 1.5 - AF 24 M = **180 Nm** (180 - 210 Nm)

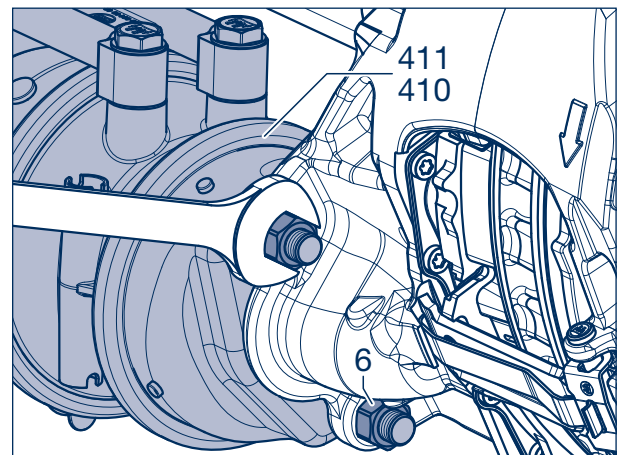

Figure 14

- [11] Remove both plugs (arrows) from the deepest drain holes of the new brake cylinder (410, 411). All other vent holes must remain sealed.
- [12] Connect the brake lines (air connections) and check the sealing. The brake lines must be routed such that they do not twist or can rub against other components.



Repair note!
When connecting the compressed air lines to the brake cylinder, make sure the movement of the brake caliper is not obstructed by any adjacent components.

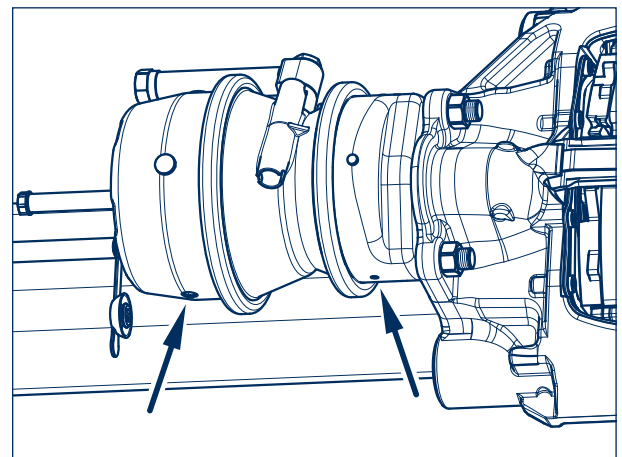

Figure 15



Repair note!
Do not mix up the lines!

- [13] Release the parking brake by venting compressed air connection 1.2 with at least 6 bar. Loosen and unscrew the nut (3) on the spindle (4).
- [14] Remove the washer (5) from the spindle (4).
- [15] Turn the spindle (4) 90° and remove it from the brake cylinder (410, 411).

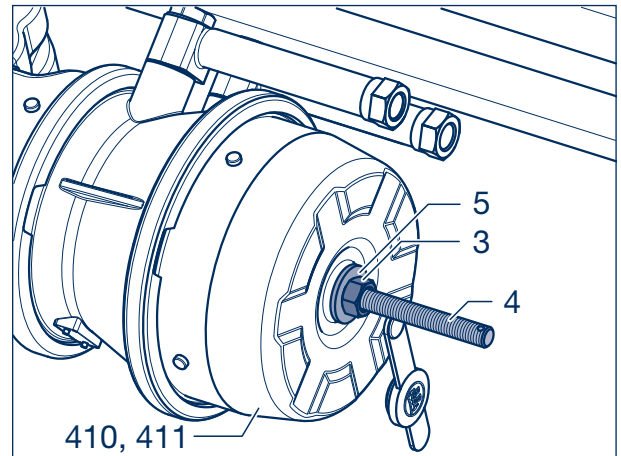

Figure 16

- [16] Close the bore hole with the lock (1) and fit the spindle (4) with the nut (3) and a washer (5) onto the brake cylinder (410, 411).
- [17] Screw on the protective cap with thread (2).

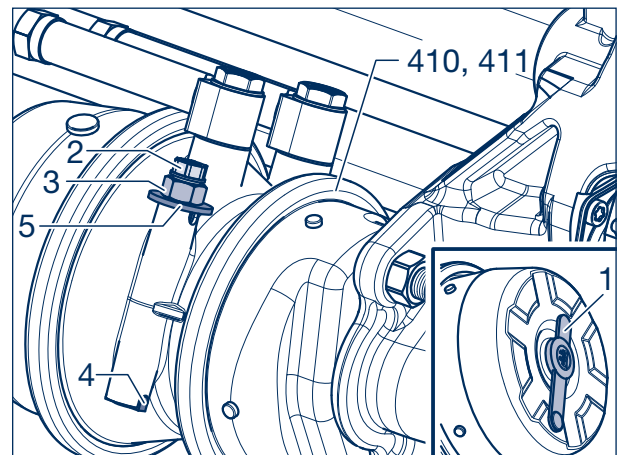

Figure 17

In other versions, screw in the spring brake bolt up to the stop and tighten it.

Tightening torque:

M = **40 Nm** (30 - 50 Nm).



Warning!
The spring-loaded brake does not function if the spring brake screw is not screwed in.



Repair note!
Check the functioning and effectiveness of the brake system!

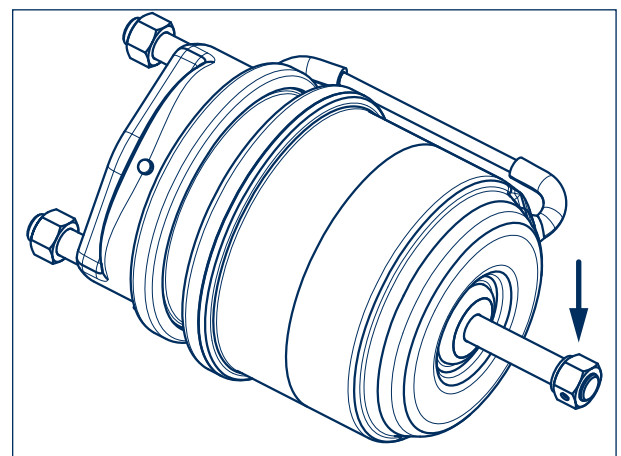

Figure 18

14 Changing the brake disc

ECO Plus 3	TS2 3709	ET 0	Page 74
		ET 120	Page 64
	TS2 4309	ET 0	Page 64
		ET 120	Page 64
ECO ^{Plus}	TS2 3709	ET 0	Page 74
		TS2 4309	ET 0

14.1 Changing the brake disc for axles with ECO Plus 3 Unit:

- TS2 3709 with ET 120
- TS2 4309 with ET 0 / ET 120

with ECO Plus Unit

- TS2 4309 with ET 0 (10 t)

- [1] Prevent the vehicle from rolling away. Release the service and parking brake.
- [2] Unscrew the hub cap (460) from the wheel hub.
- [3] Loosen the wheel nuts.
- [4] Support the vehicle to prevent accidents.
- [5] Raise the axle until the tyres are free.
- [6] Unscrew the wheel nuts and remove the wheel from the hub.
- [7] Knock out the wheel bolts (472).



Repair note!

Ensure sufficient space between the bolts and the brake when knocking out the wheel bolts. Do not damage the thread of the wheel studs; use a copper hammer if necessary.

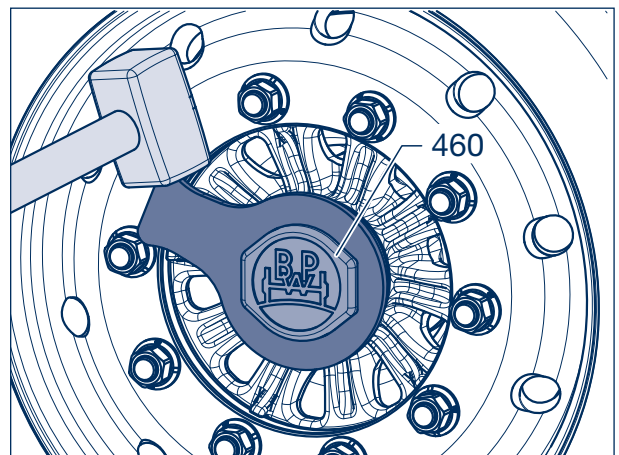

Figure 1

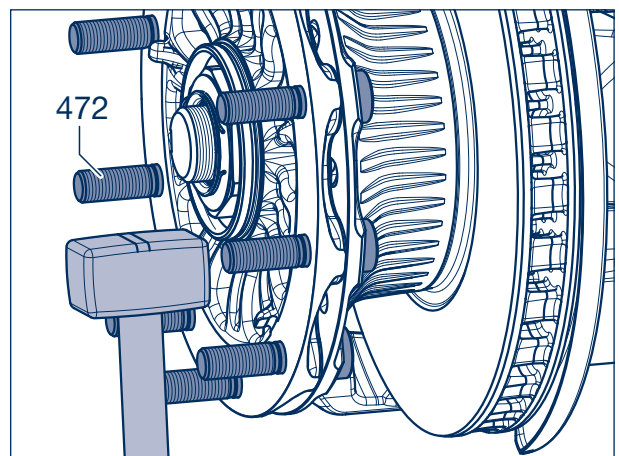

Figure 2



Warning!
DANGER OF INJURY!
 Secure the brake disc (380) with a jack
 or other type of support to prevent it
 from falling.

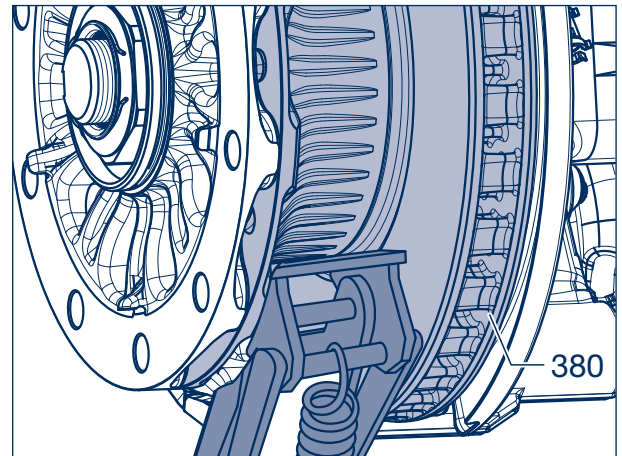

Figure 3

- [8] Remove the hooked spring ring (448) and locking piece (449) from the axle nut (446).

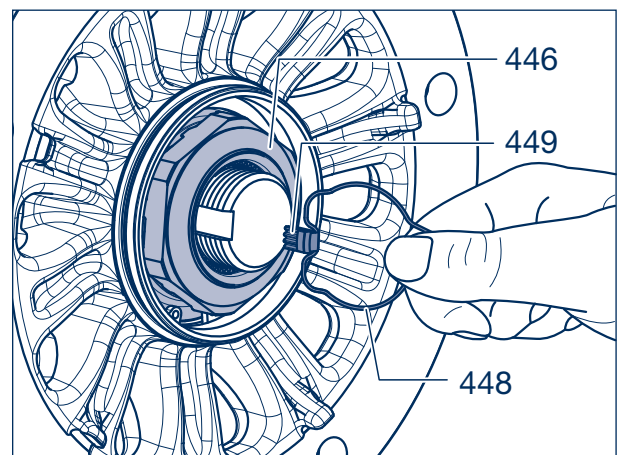

Figure 4

- [9] Unscrew the axle nut (446, AF 95). When you do this, the complete ECO Unit (434) is pulled off the bearing seats of the axle stub.



Danger!
DANGER OF INJURY!
 The ECO Unit must be secured against
 falling when it is removed.
 Use a lifting device or second person
 for assistance.

- [10] Remove the ECO Unit (434).

 **Dismantling the ECO Unit, see chapter 15.1 and 15.2.**

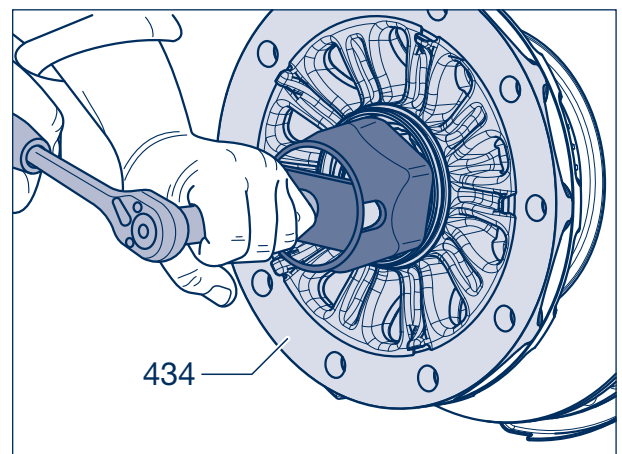

Figure 5

14 Changing the brake disc

[11] Remove the sealing cap (370) of the resetter.

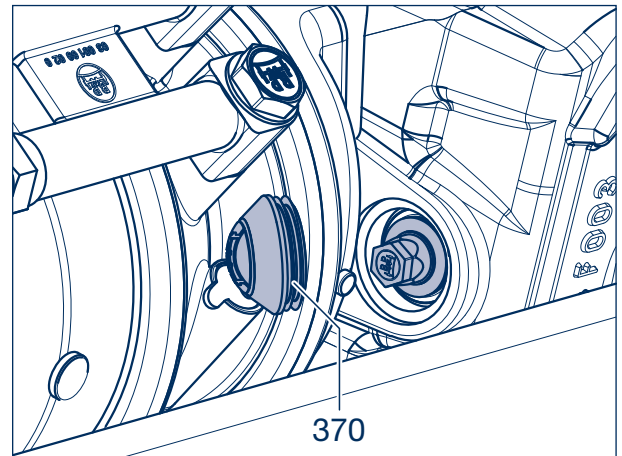

Figure 6

[12] Using a spanner (AF 13), turn the resetter counterclockwise until the bellow with pressure plate is completely reset.

Max. reset moment: 15 Nm



Repair note!

If the max. reset torque is exceeded, the adjustment can be irreparably damaged.



Attention!

Do not use a cordless screwdriver or impact wrench. Using these tools would cause considerable damage!

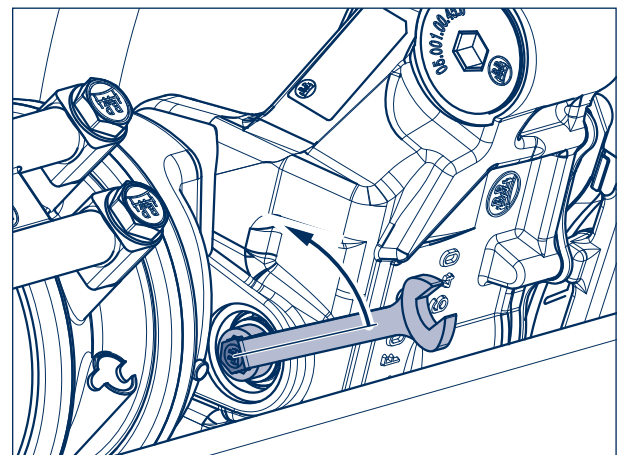

Figure 7

[13] Pull the spring split pin (398) out of the bolt (396) with a spring plier.



Caution!

Apply counter pressure to the brake linings as required so that they do not fall out of the lining groove when the pad retainer is removed.

[14] Depress the pad retainer (395) with the clamping spring (394) and remove the bolt (396) with the holding clamp (397).

[15] Depress the pad retainer (395) with clamping spring (394).

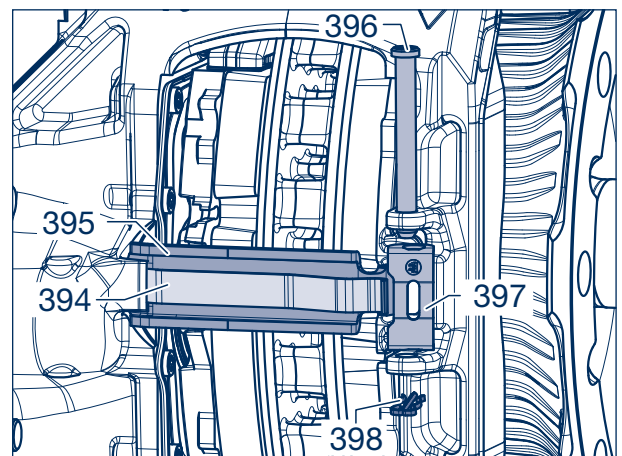

Figure 8

- [16] Remove the brake linings (390, 391).

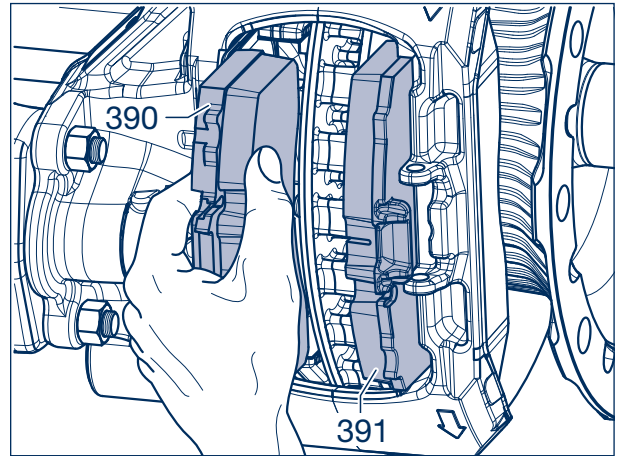

Figure 9

- [17] Tilt the brake disc (380) and remove it from the axle beam or from the brake.



Danger!
DANGER OF INJURY!
The brake disc must be secured against falling when it is removed. Use a lifting device or second person for assistance.

- [18] Replace the brake disc (380).
- [19] After the brake disc (380) has been removed, check the condition of the brake; see chapter 6, pages 27 to 29.

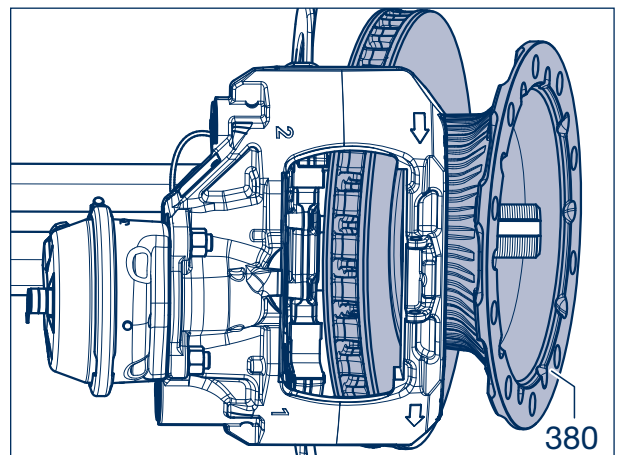

Figure 10

- [20] If no defects are found, you can continue to replace the brake disc (380).
- [21] Lever both wearing plates (389) off of the brake anchor. Clean the lining groove and the seats of the wearing plates on the brake anchor and remove corrosion.

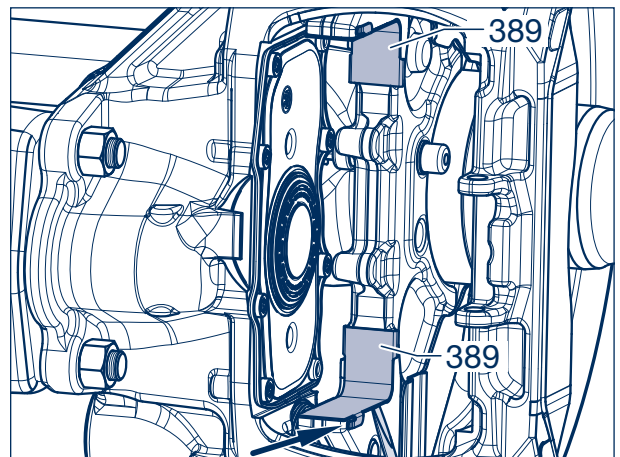

Figure 11

14 Changing the brake disc

- [22] Unscrew the locking screws M 10 x 15 (510 / AF 13) from the welded-on plate on the axle beam.

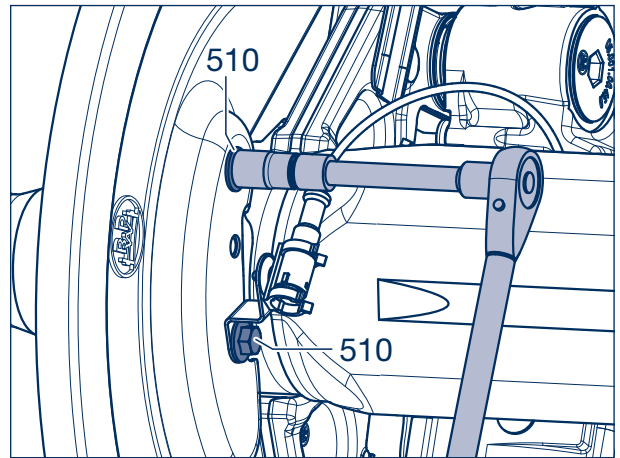

Figure 12

- [23] Remove the dust cover (501, 502) and, if necessary, the supports (585, 586) with the sensor (570).

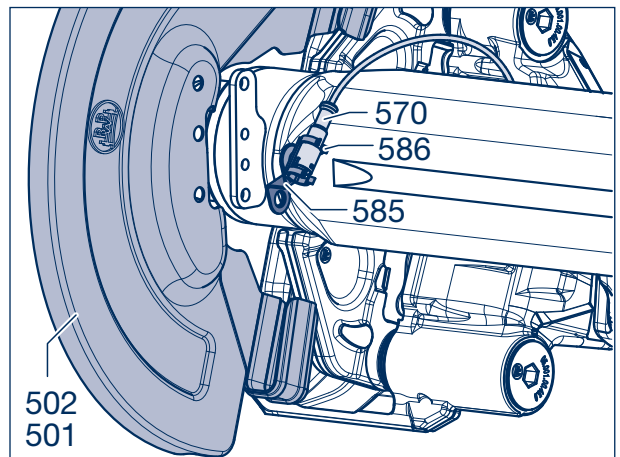

Figure 13

- [24] Check the sensor (570) for damage and displacement (displacement force 100 - 200 N).
- [25] Lubricate the clamping bush (571) and the sensor (570) with special grease (replace the clamping bush). Before fitting hubs, always press the clamping bush (571) and the sensor (570) until they make contact.

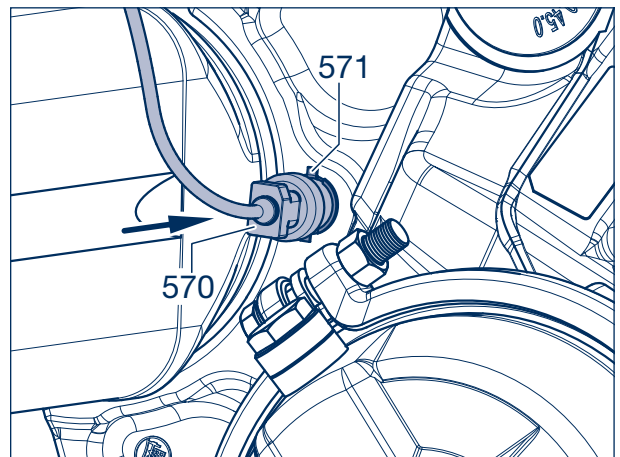

Figure 14

- [26] Secure the dust cover (501, 502) to the welded plate on the axle beam with the locking screws (510) M 10 x 15 (AF 13) and the support (585) with the sensor (570).

Tightening torque :

$$M = 25 \text{ Nm (23 - 28 Nm)}$$

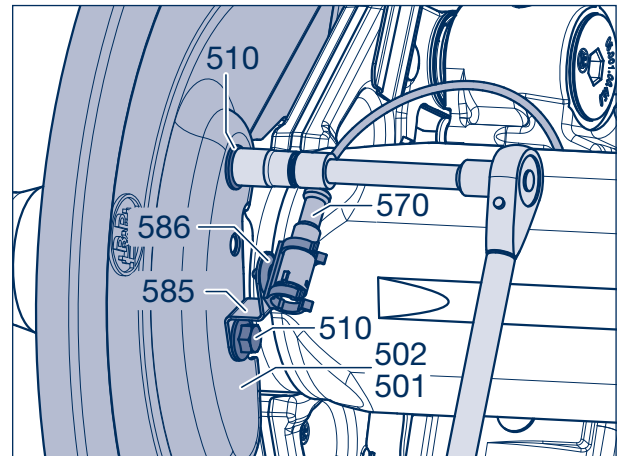

Figure 15

- [27] Use a microfibre cloth to clean the bearing seats of the axle stub (metal must be bright, dry and free of grease) and apply **Castrol White T** thinly all around using a microfleece brush. After application, no bright metal surfaces must remain. Castrol White T must not be thinned.

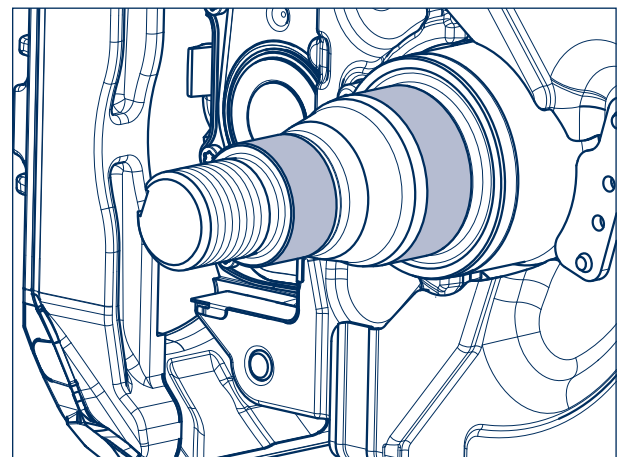

Figure 16



Repair note!
Remove any corrosion protection prior to installing the brake disc.

- [28] Insert the new brake disc (380) into the brake, slide it over the axle housing, and place it securely on a jack or other support.



Repair note!
Protect the ABS sensor against damage when the brake disc is being installed.

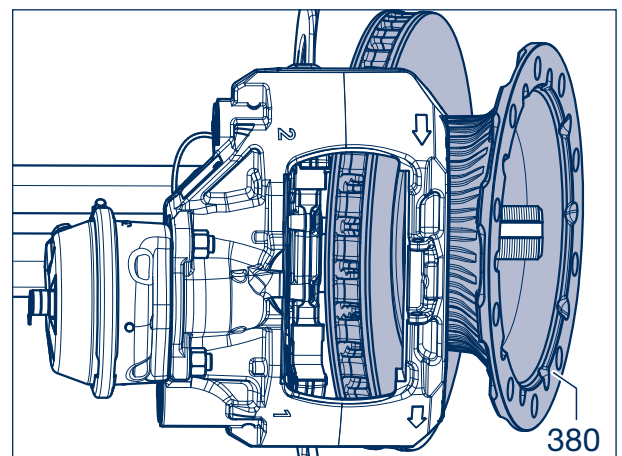

Figure 17

14 Changing the brake disc

- [29] Clean the contact surface (arrow) to the brake disc (380) at the wheel hub (435) and mount the ECO Unit (434).

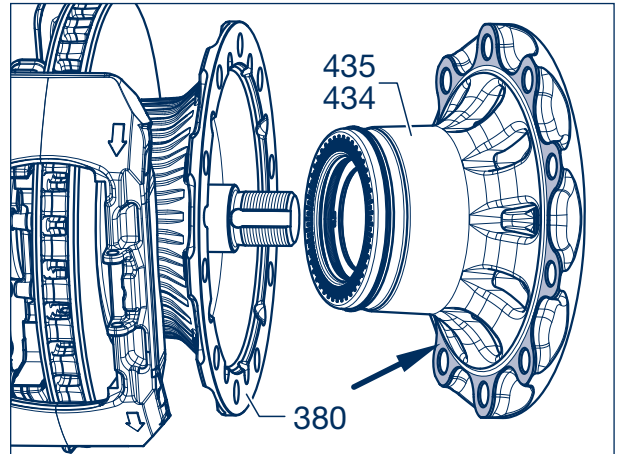

Figure 18

- [30] Align the tab of the washer (445/arrow) to the groove of the stub axle by turning the axle nut (446) and gently press the ECO Unit.
- [31] Push the ECO Unit centrally onto the stub axle.
- [32] Tighten the axle nut (446, AF 95). The complete ECO Unit (434) is pulled onto the axle stub along with the axle nut.

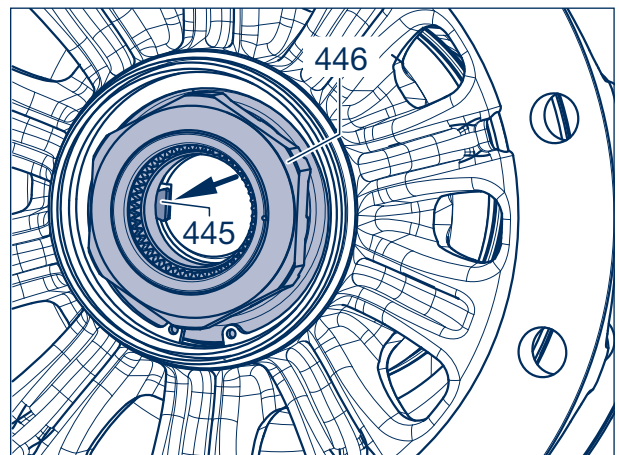

Figure 19

- [33] Tighten the axle nut (446) using a hexagon socket spanner (BPW no. 05.364.26.05.0) whilst continuously rotating the ECO Unit (434). Several rotations are necessary for the tothing to slip over the axle nut.
(Do not turn back the axle nut.)



Attention!
Do not use an impact wrench.

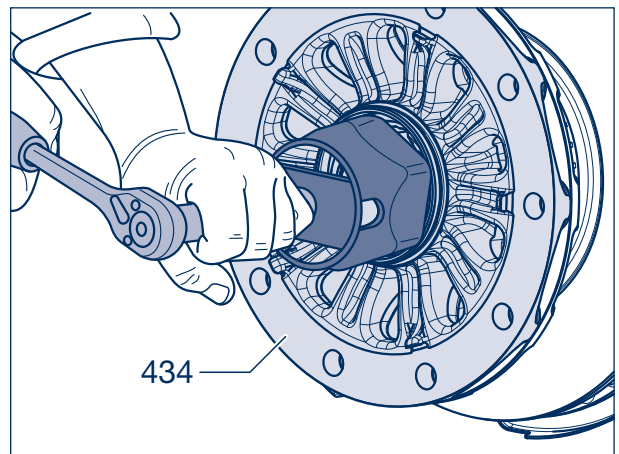

Figure 20

- [34] Fit the locking piece (449) in the groove between the axle stub and the nut (446) (do not turn back the axle nut).

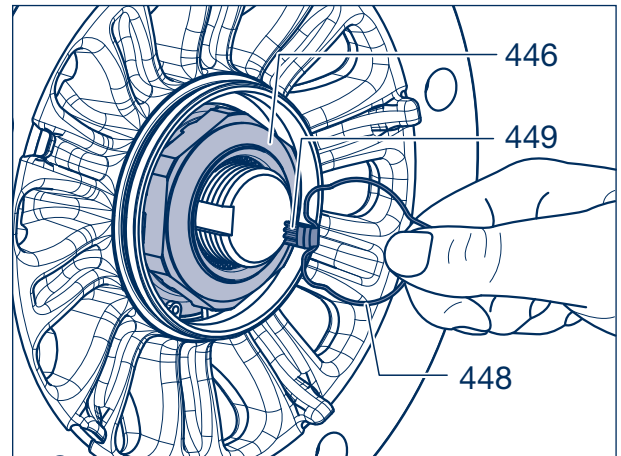

Figure 21

- [35] Insert the hooked spring ring (448) behind the formed edge of the axle nut (446).

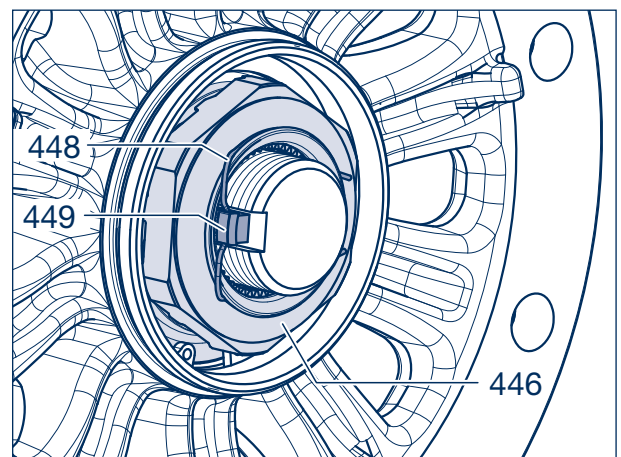

Figure 22

- [36] Align the bore holes for the wheel studs (472) of the ECO Unit (434) and the brake disc (380).
- [37] Insert the wheel bolts (472) into the brake disc / ECO Unit as far as possible. Make sure the wheel stud head is correctly seated on the brake disc (380) (torsion protection); see figure 25.

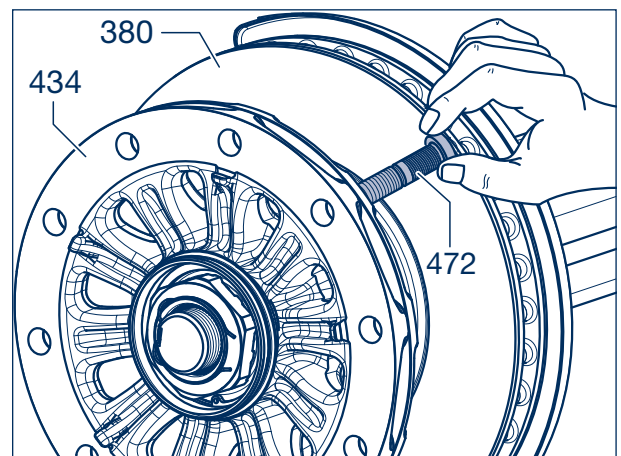

Figure 23

14 Changing the brake disc

- [38] Tighten the wheel bolts (472) crosswise using a ring (BPW no. 02.5683.92.00) and nut until they make contact with the brake disc (380).

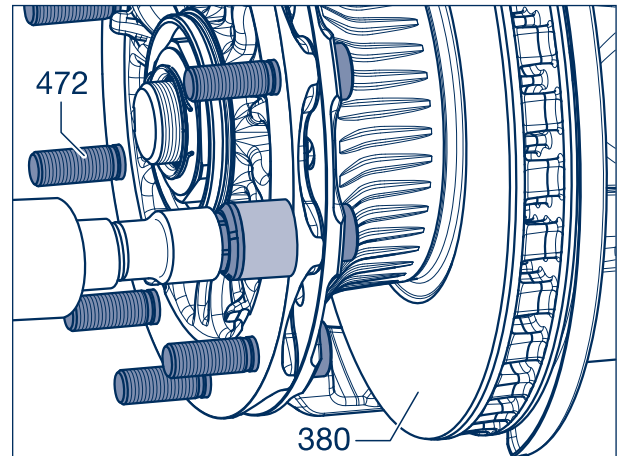

Figure 24



Repair note!
The flattened side of the wheel stud (472) must rest against the brake disc collar (380).

- [39] Remove the jack or support device.
[40] Install brake linings (390) and wear plates (389), then adjust the clearance, see chapter 8, page 36 - 40.

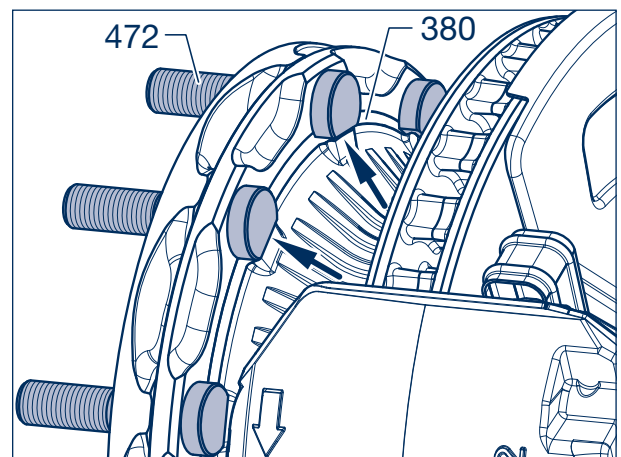

Figure 25

- [41] Attach the wheels.



Repair note!
Only use wheels that have a valve outside the wheel brace.

- [42] Screw on the wheel nuts (479).
[43] Lower the axle and tighten the wheel nuts to the required tightening torque.



Warning!
The tightening torque of the wheel nuts must be checked after the first run under load and, if necessary, retightened to the prescribed value.

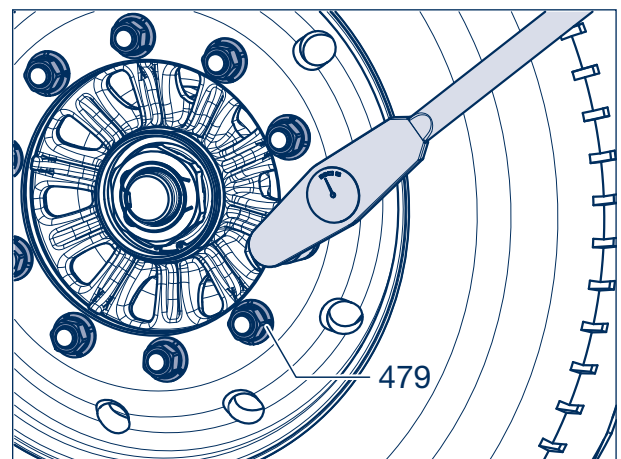

Figure 26

- [44] Insert a new O-ring (459) into the groove in the wheel hub (435, arrow). (The O-ring is not required for axles with ECO Plus Unit).

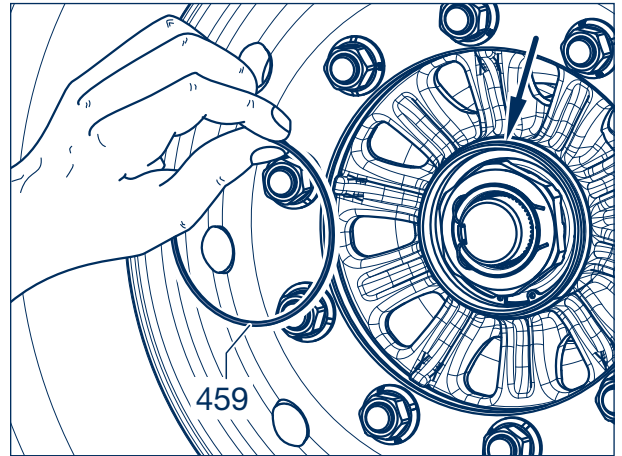

Figure 27

- [45] Cover the hub cap (460) in the area of the O-ring contact surface (only with ECO Plus 3) and the thread with a thin coat of BPW special longlife grease **ECO-Li^{Plus}**.
- [46] Screw the hub cap onto the wheel hub (460) and tighten it to the prescribed tightening torque.

Tightening torques:

ECO Plus 3 hub cap	AF 110	350 Nm
ECO Plus hub cap	AF 110	800 Nm

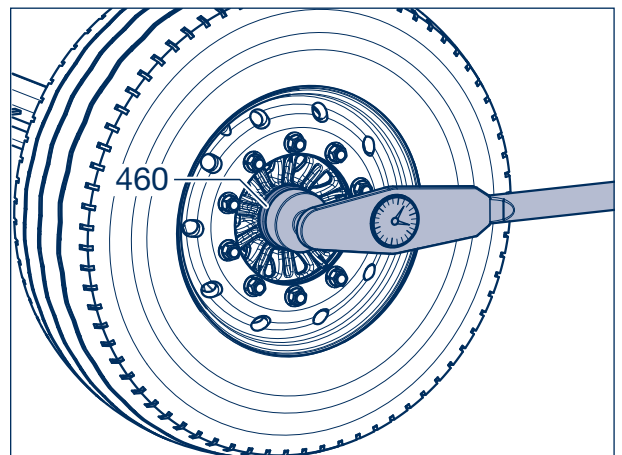

Figure 28



Warning!

The braking effect of new discs and linings is only at its optimum after a few braking operations. For this reason, run in new brake linings while avoiding lengthy and unnecessarily sharp brake operations.

14 Changing the brake disc

14.2 Replacing the brake disc for axles with ECO Plus 3 Unit: - TS2 3709 with ET 0 (9 - 10 t) with ECO Plus Unit - TS2 3709 with ET 0 (10 t)

- [1] Prevent the vehicle from rolling away. Release the service and parking brake.
- [2] Unscrew the hub cap (460) from the wheel hub.
- [3] Loosen the wheel nuts.
- [4] Support the vehicle to prevent accidents.
- [5] Raise the axle until the tyres are free.
- [6] Unscrew the wheel nuts and remove the wheel from the hub.
- [7] Remove the sealing cap (370) of the resetter.

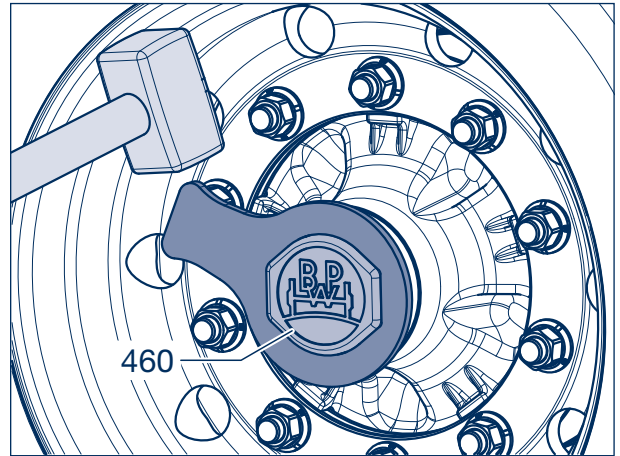

Figure 29

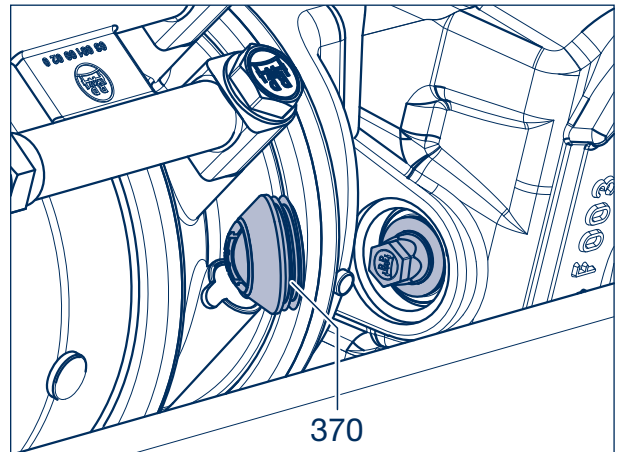

Figure 30

- [8] Using a spanner (AF 13), turn the resetter counterclockwise until the bellow with pressure plate is completely reset.

Max. reset moment: 15 Nm



Repair note!
If the max. reset torque is exceeded, the adjustment can be irreparably damaged.



Attention!
Do not use a cordless screwdriver or impact wrench. Using these tools would cause considerable damage!

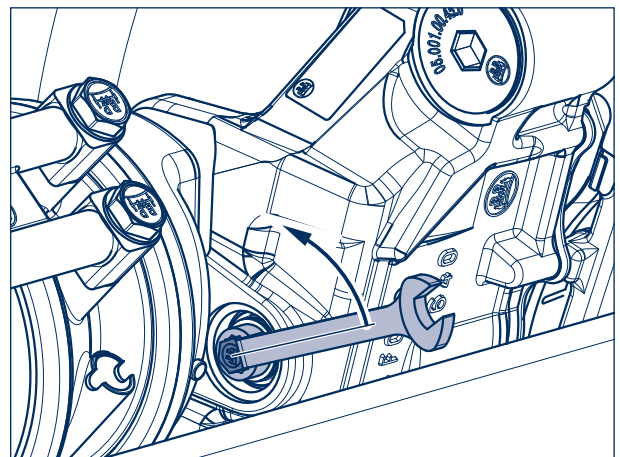

Figure 31

- [9] Pull the spring split pin (398) out of the bolt (396) with a spring plier.



Caution!

Apply counter pressure to the brake linings as required so that they do not fall out of the lining groove when the pad retainer is removed.

- [10] Depress the pad retainer (395) with clamping spring (394) and remove the bolt (396) with holding clamp (397).
- [11] Remove the pad retainer (395) with clamping spring (394).

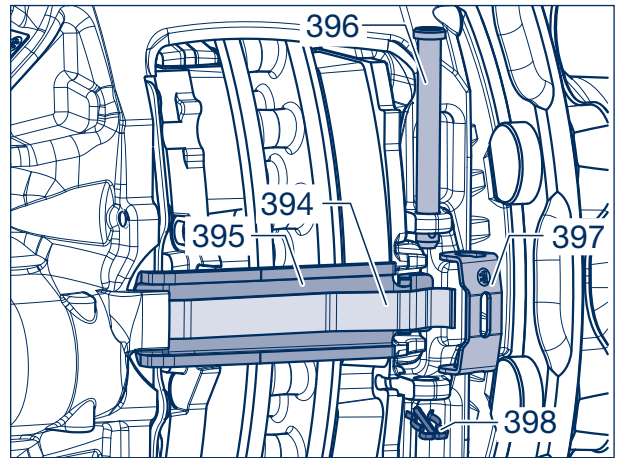

Figure 32

- [12] Remove the brake linings (390, 391).

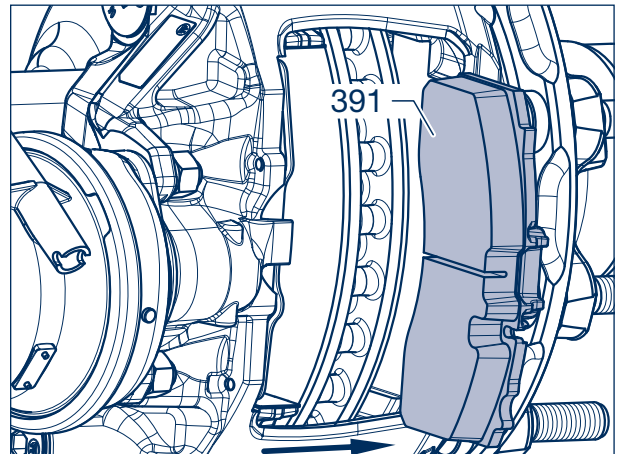

Figure 33

- [13] Unscrew the sealing caps of the caliper guide (335) using the adapter (BPW no.: 02.0130.47.10 or 02.0130.49.10, AF 14).

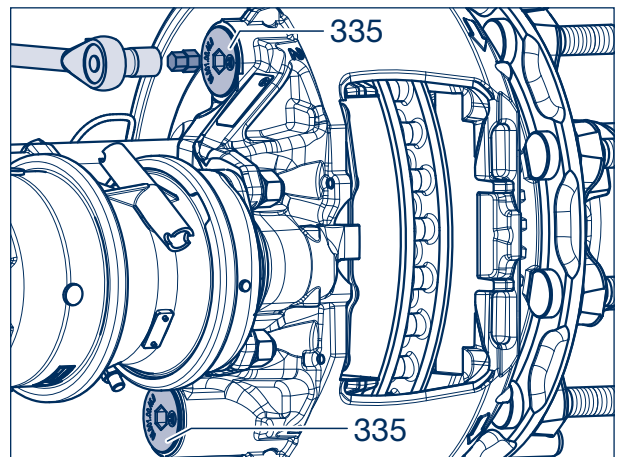

Figure 34

14 Changing the brake disc



Warning!
Before undoing the cylinder head screws, secure the brake caliper to prevent it from falling.

- [14] Unscrew the cylinder head screws (325, 345) with the adapter AF 14, according to the version T12, T14, T17 or T18 (see page 19 and 20).

If there is enough clearance, a ratchet with a box spanner AF 14 can be used.



Danger!
DANGER OF CRUSHING!
Only hold the brake caliper on the outside. Never place fingers between the brake caliper and the brake anchor!
Never attach a lifting device to the pad retainer, since the pad retainer can be damaged.



Danger!
DANGER OF INJURY!
The brake caliper must be secured when it is removed to prevent it from falling. Use a hoist or second person for assistance.

- [15] Remove the brake caliper from the brake carrier.



Caution!
DANGER OF ACCIDENT!
Do not open or dismantle a brake caliper. Only use replacement brake calipers.

- [16] Remove the hooked spring ring (448) and locking piece (449) from the axle nut (446).

- [17] Unscrew the axle nut (446, AF 95); this pulls the complete ECO Unit (434) off the bearing seats of the axle stub.



Danger!
DANGER OF INJURY!
The ECO Unit must be secured against falling when it is removed. Use a lifting device or second person for assistance.

- [18] Remove the ECO Unit (434).

-  **Dismantling the ECO Plus 3 Unit, see chapter 15.1.**
Dismantle the ECO Unit, see chapter 15.2.

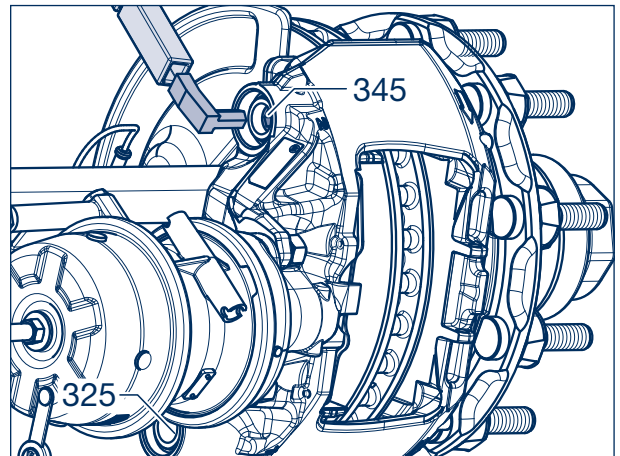

Figure 35

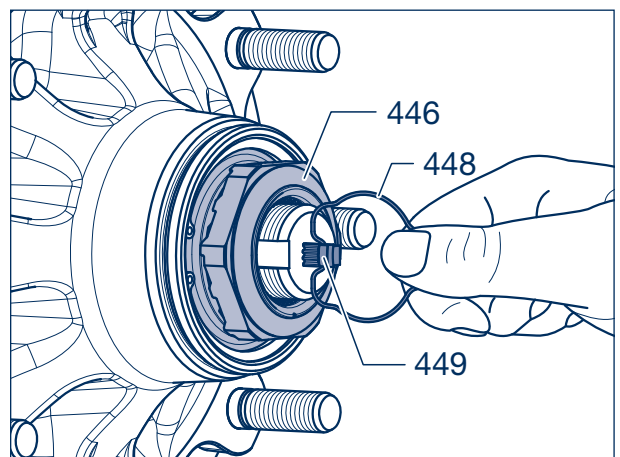

Figure 36

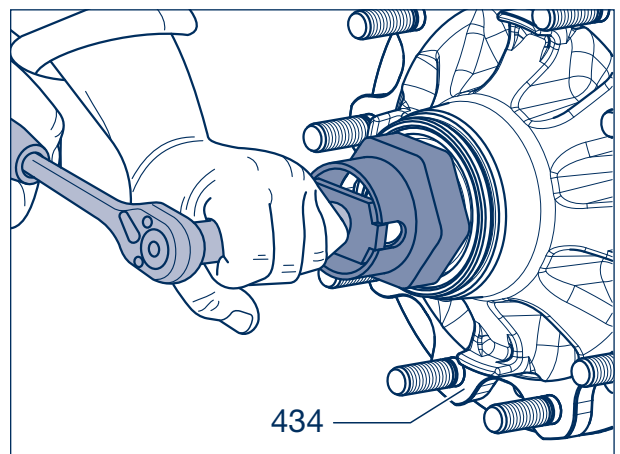



Figure 37

- [19] Lever both wearing plates (389) off of the brake anchor.
- [20] Clean the seats of the wearing plates on the brake anchor.
- [21] Fit new wearing plates (389) greased on the rear side with BPW special longlife grease ECO-Li^{Plus} on the brake anchor.
The lateral fixing brackets (detail) fix the plates on the brake anchor.
-  For assembly / disassembly of ABS on square axle beams, see page 79, work step [39].

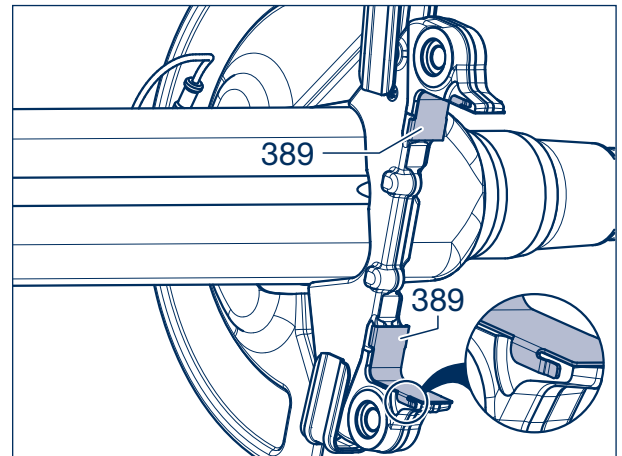

Figure 38

Round axle beam

- [22] Unscrew locking screws of the heat protection cover M 8 x 20 (551 / SW 13 / Torx Plus 40IP) and the dust cover M 10 x 15 (510 / SW 13) from the welded plate on the axle beam.
- [23] Remove the cable tie (569) used to fasten the sensor cable.

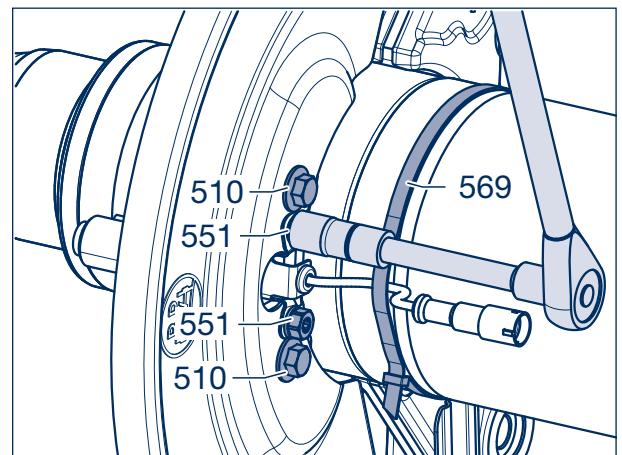

Figure 39

- [24] Remove the dust cover (501, 502), and the heat protection cover (590).

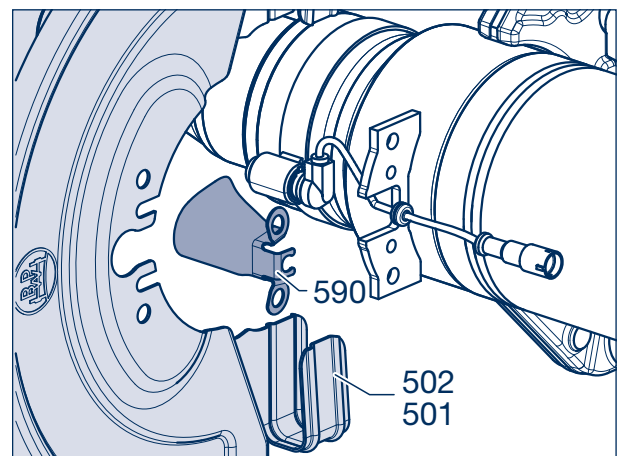

Figure 40

14 Changing the brake disc

- [25] Check sensor (570) for damage and displacement (displacement force 100 - 200 N).
- [26] If it is necessary to replace the sensor bracket (542), undo the locking screw M 8 x 20 (551 / SW 13 / Torx Plus 40IP) on the sensor bracket and pull the sensor bracket off the axle spindle together with the sensor.
- [27] If necessary, replace the clamping bush (571) and insert it into the sensor bracket.
- [28] Smear the clamping bush with special grease.
- [29] Fit the sensor (570) and press it together with the clamping bush (571) until they make contact.
- [30] Push the pre-assembled unit onto the axle spindle.

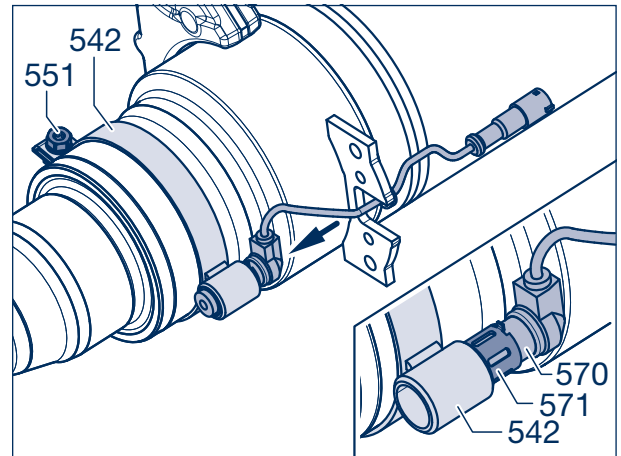

Figure 41

- [31] Attach the rubber ring (513) and heat protection cover (590) to the ABS cable.
- [32] Loosely screw the heat protection cover onto the welded plate on the axle beam using 2 locking screws M 8 x 20 (551 / SW 13 / Torx Plus 40IP). Do not tighten them.
- [33] Fit the dust cover (501, 502) between the heat protection cover and welded plate (arrows) and tighten with 2 locking screws M 10 x 15 (510 / SW 13).
- [34] Tighten all locking screws (510, 551).
Tightening torque :
M = **25 Nm** (23 - 28 Nm)

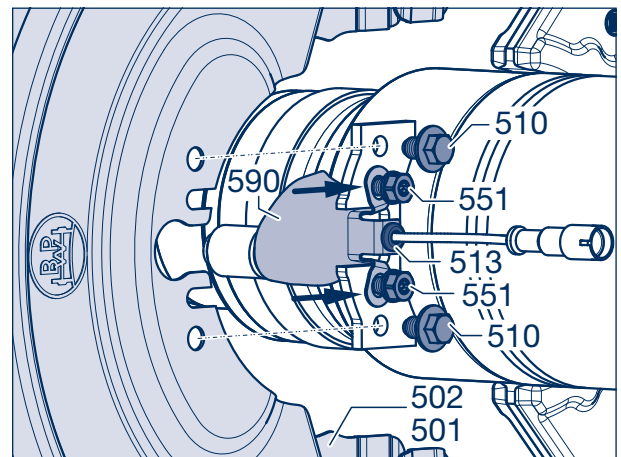

Figure 42

- [35] Align the sensor bracket (542) and mounted sensor radially with the heat protection cover; see detailed illustration Fig. 43).
- [36] Adjust the sensor bracket axially so there is a distance of 51 mm between the chamfer on the axle spindle and the rear edge of the sensor bracket.
- [37] Tighten the sensor bracket in the set position with the locking screw (551 / SW 13 / Torx Plus 40IP).
Tightening torque :
M = **25 Nm** (23 - 28 Nm)

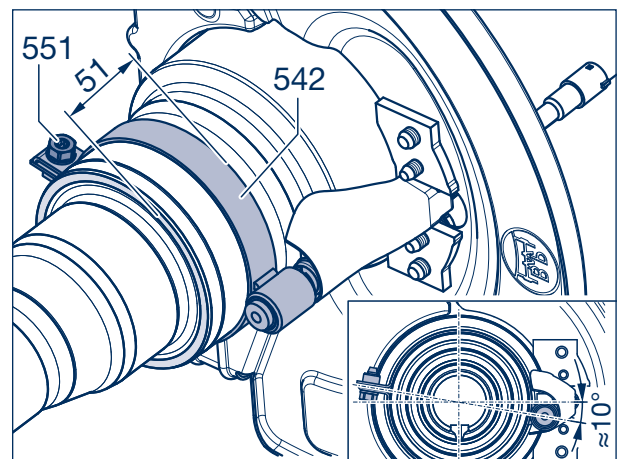

Figure 43

- [38] Tighten the sensor cable (570) and fix it to the axle beam with a cable tie (569).



Repair note!

The ABS sensor cable must not be between the heat protection cover (590) and the axle beam.

- ☞ For the rest of the assembly process, see page 80, work step [44].

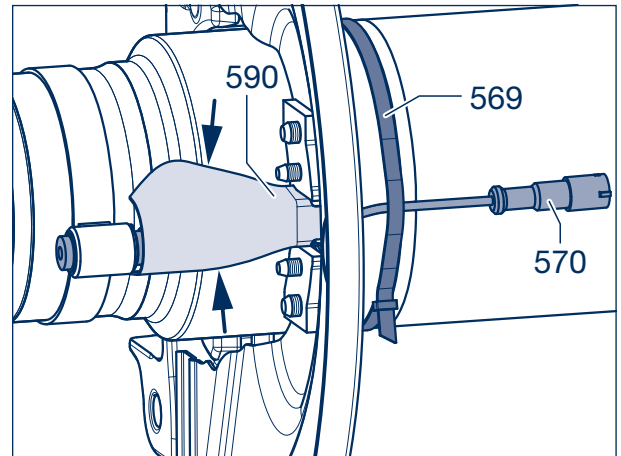

Figure 44

Square axle beam

- [39] Unscrew the locking screws M 10 x 15 (510 / AF 13) from the welded-on plate on the axle beam.

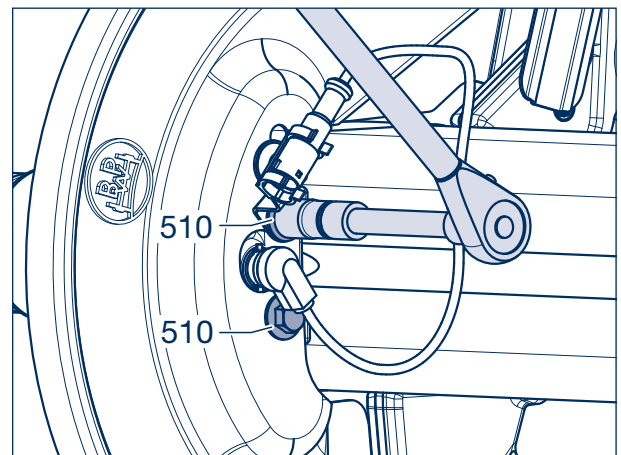

Figure 45

- [40] Remove the support (585) with the sensor connector (586), the dust cover (501, 502), the serrated lock washer (587) and the heat protection cover (590) if necessary.

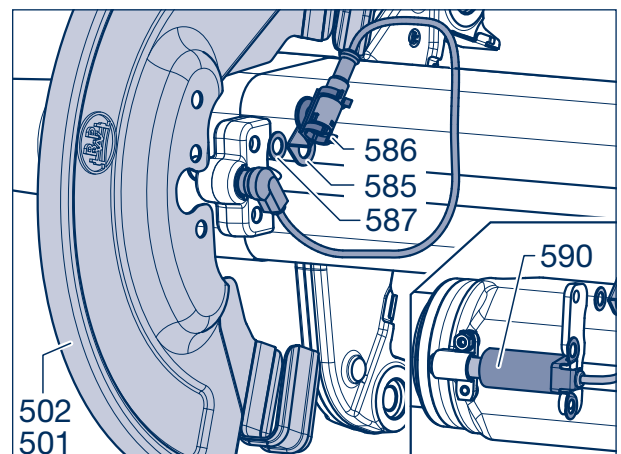

Figure 46

14 Changing the brake disc

- [41] Check the sensor (570) for damage and displacement (displacement force 100 - 200 N).
- [42] Lubricate the clamping bush (571) and the sensor (570) with special grease (replace the clamping bush). Before fitting hubs, always press the clamping bush and sensor until they make contact.

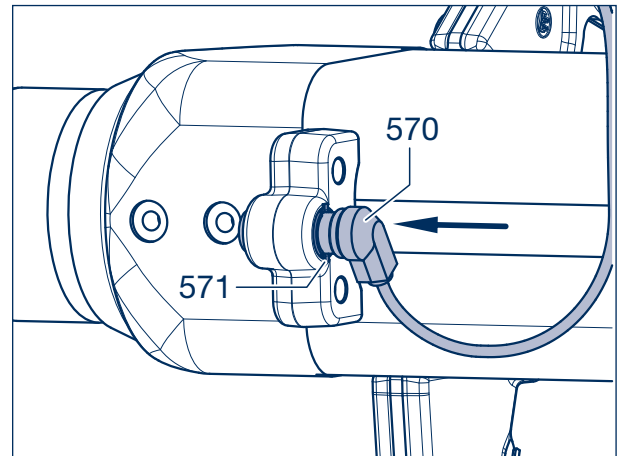

Figure 47

- [43] Fasten the dust cover (501, 502), the support (585) with sensor connector and if nec. the heat protection cover (590) to the welded-on support on the axle beam with the locking screws (510) M 10 x 15 (AF 13) and the serrated lock washer (587).

Tightening torque :

$M = 25 \text{ Nm}$ (23 - 28 Nm)

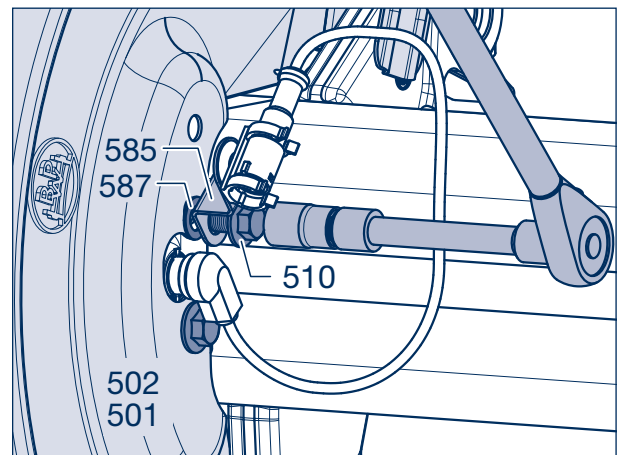

Figure 48

- [44] Use a microfibre cloth to clean the bearing seats of the axle stub (metal must be bright, dry and free of grease) and apply **Castrol White T** thinly all around using a microfleece brush. After application, no bright metal surfaces must remain. Castrol White T must not be thinned.

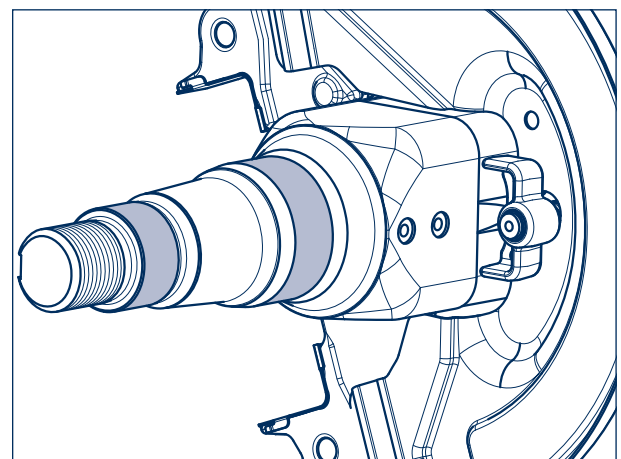

Figure 49

- [45] Drive out the wheel studs (472) from the removed hub brake disc unit (do not damage the wheel stub threads).

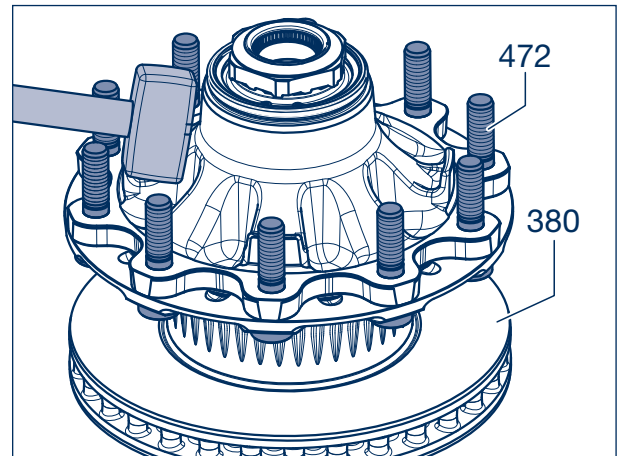

Figure 50



Repair note!
Only place the auxiliary tool for separating the hub (435) and disc (380) in the base of the lip (arrow).

- [46] Replace the brake disc (380).



Repair note!
Remove any corrosion protection prior to installing the brake disc.

- [47] The contact surface of the hub and brake disc must be clean and flat.

- [48] Lay the ECO Unit (434) on the new brake disc (380).

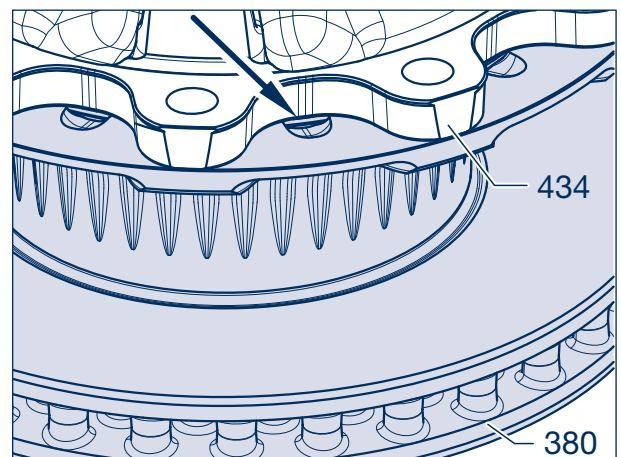

Figure 51

- [49] Align the bore holes for the wheel studs (472) of the ECO Unit (434) and the brake disc (380).

- [50] Insert the wheel bolts (472) into the brake disc / ECO Unit as far as possible. Make sure the wheel bolt head is correctly placed on the brake disc (380) (torsion protection).

- [51] Tighten the wheel studs (472) crosswise using a ring (BPW no. 02.5683.92.00) and nut until they make contact with the brake disc (380).



Repair note!
The flattened side of the wheel stud (472) must rest against the brake disc collar (380).

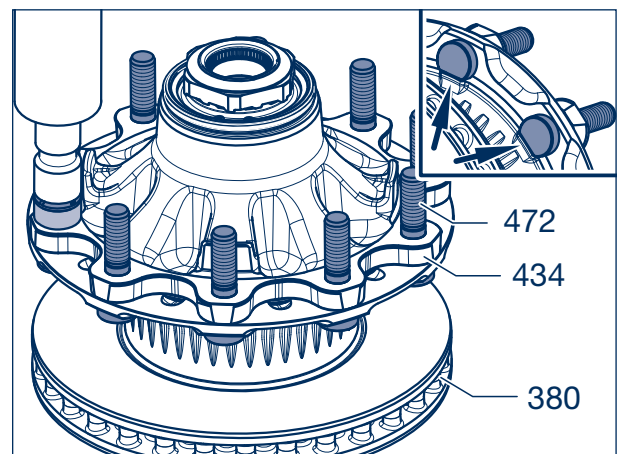

Figure 52

14 Changing the brake disc

- [52] Align the tab of the washer (445/arrow) to the groove of the axle stub by turning the axle nut (446) and gently push the hub brake disc unit.
- [53] Push the complete hub bearing unit with brake disc centrally onto the axle stub.
- [54] Screw on the axle nut (446, AF 95).
The ECO Unit (434) with brake disc (380) is pulled onto the axle stub with the axle nut.

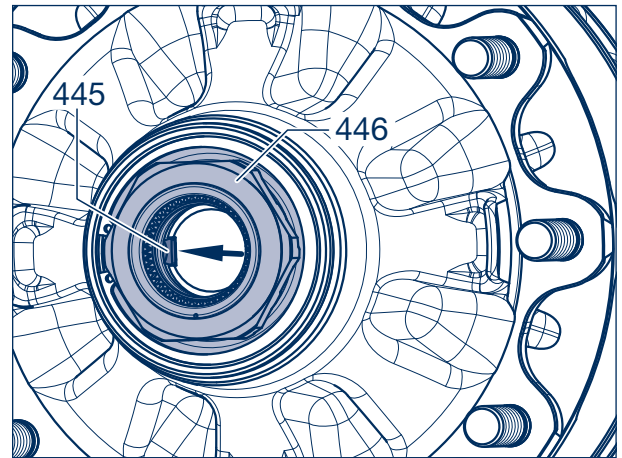

Figure 53

- [55] Tighten the axle nut (446) using a hexagon socket spanner (BPW no. 05.364.26.05.0) whilst continuously rotating the ECO Unit (434). Several rotations are necessary for the tothing to slip over the axle nut.
(Do not turn back the axle nut.)



Attention!
Do not use an impact wrench.

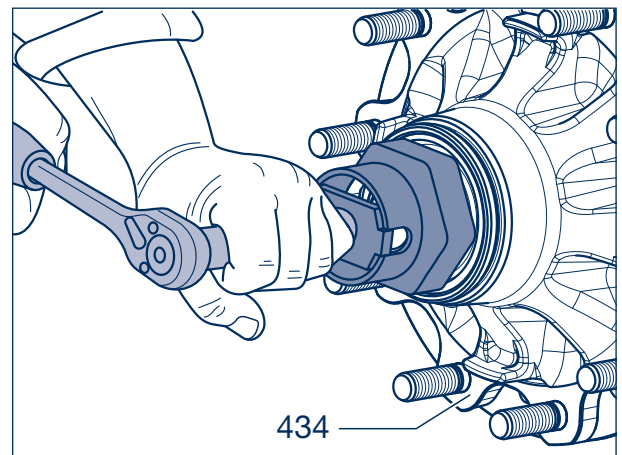

Figure 54

- [56] Fit the locking piece (449) in the groove between the axle stub and the nut (446) (do not turn back the axle nut).

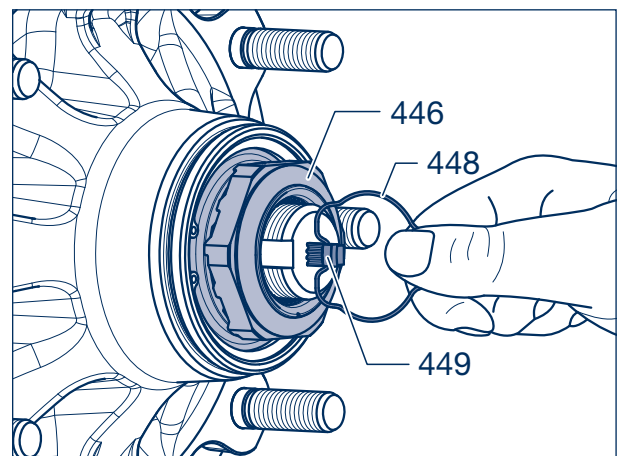

Figure 55

- [57] Insert the hooked spring ring (448) behind the formed edge of the axle nut (446).

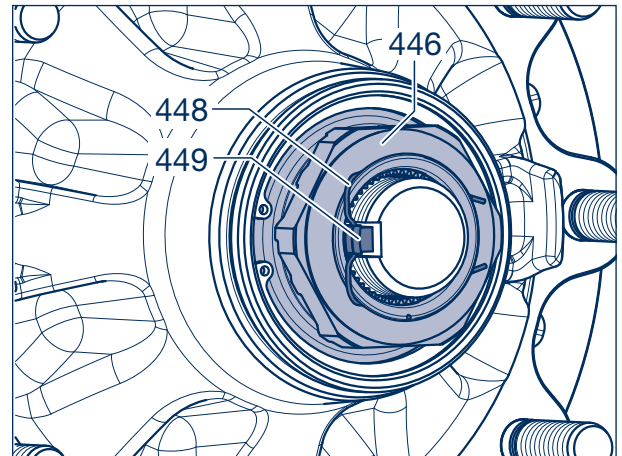

Figure 56

See steps [7] to [11] from page 49 if replacement brake calipers are used.



Repair note!

Before assembly, the brake caliper must be checked for its condition and damage. Repair or replace it if necessary.



Repair note!

Ensure that the bellow (354) and the ring (356) are seated properly on the guide pin when mounting the brake caliper.



Repair note!

Ensure that the bellows (354) and rings (356) have sufficient clearance when the brake caliper is positioned, to prevent any damage from occurring.

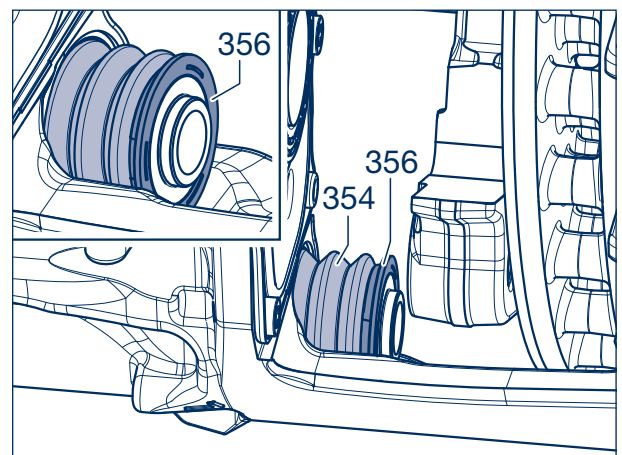

Figure 57

- [58] Move the brake caliper with the fixed bearing (long guide pin) down onto the brake anchor plate.



Caution!

Cylinder head screws (325, 345) must not be re-used!

- [59] Apply BPW ECO Disc Grease to the new cylinder head screws (325, 345) on the thread and the screw seating.
- [60] Using an adapter AF 14, screw in according to version T12, T14, T17 or T18 (see page 18 and 19).
Do not tighten!

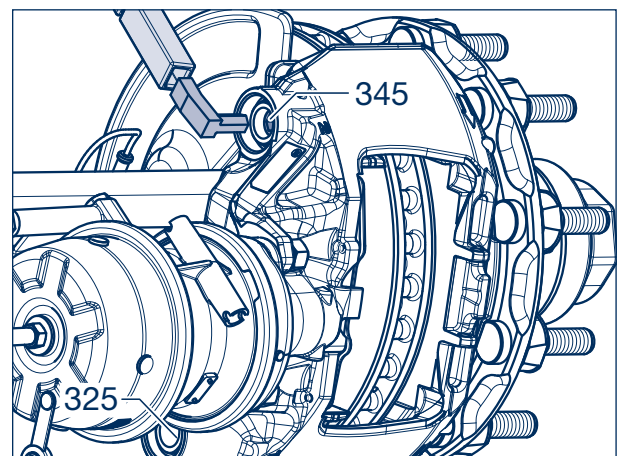

Figure 58

14 Changing the brake disc



Repair note!

For the brake function, it is essential to tighten the fixed bearing bolt (marking 1 on the brake caliper) to the required tightening torque first.

- [61] Tighten the cylinder head screw of the fixed bearing (325) with a torque of:
 $M = 260 \text{ Nm}$ (250 - 270 Nm)
 or otherwise with
 $150 \text{ Nm} + 180^\circ$ rotation angle.

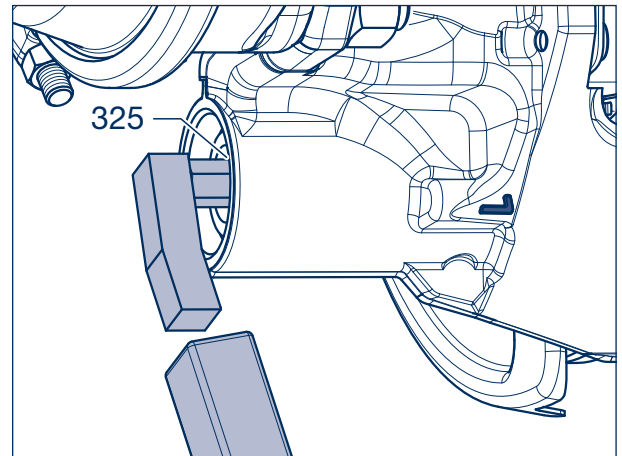

Figure 59

- [62] Tighten the cylinder head screw (345) of the floating bearing (marking 2 on the brake caliper) with a tightening torque of:
 $M = 260 \text{ Nm}$ (250 - 270 Nm)
 or otherwise with
 $150 \text{ Nm} + 180^\circ$ rotation angle.

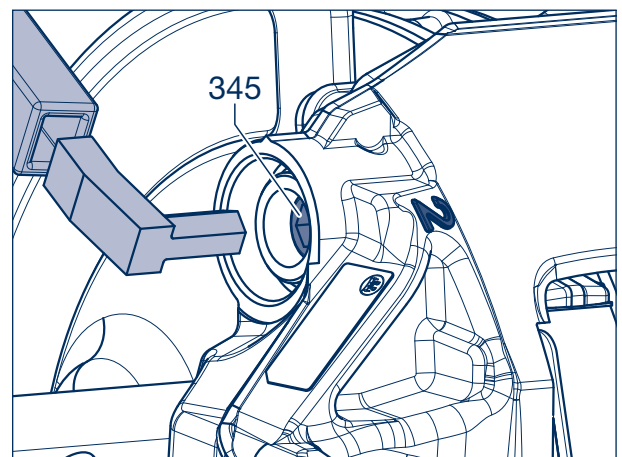

Figure 60

- [63] Push the new O-ring (336) onto a new sealing cap (335) until they make contact (arrow).
- [64] Screw in new pre-assembled sealing caps for the caliper guide (335, 336) using the adapter (BPW no.: 02.0130.47.10 or 02.0130.49.10, AF 14). For this purpose, center the brake caliper in relation to the brake disc.
 Tightening torque:
 15 Nm (15 - 20 Nm)
- [65] Check that the brake caliper can be moved easily.
- [66] Install brake linings (390) and wearing plates (389), then adjust the clearance; see chapter 8, page 36 - 40.

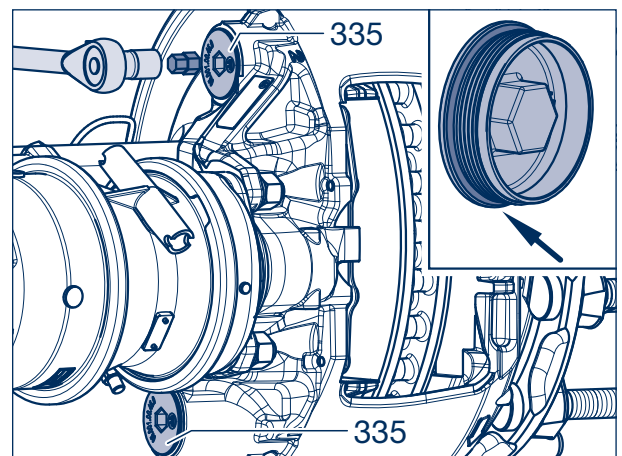

Figure 61

[67] Attach the wheels.



Repair note!
Only use wheels that have a valve outside the wheel brace.

[68] Screw on the wheel nuts.

[69] Lower the axle and tighten the wheel nuts to the required tightening torque.



Warning!
The tightening torque of the wheel nuts must be checked after the first run under load and, if necessary, retightened to the prescribed value.

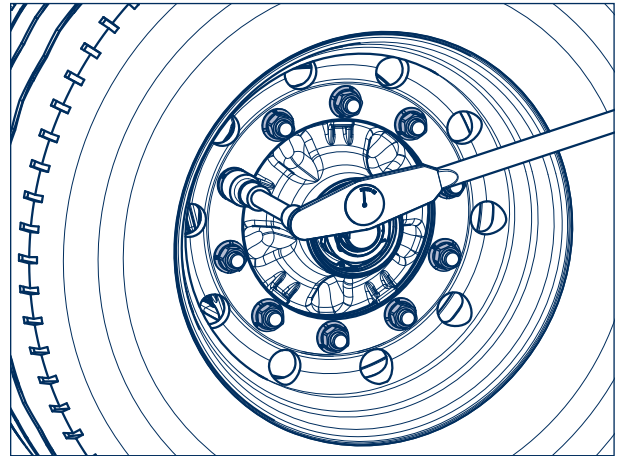

Figure 62

[70] Insert a new O-ring (459) into the groove of the wheel hub (435, arrow). (The O-ring is not required for axles with ECO Plus Unit).

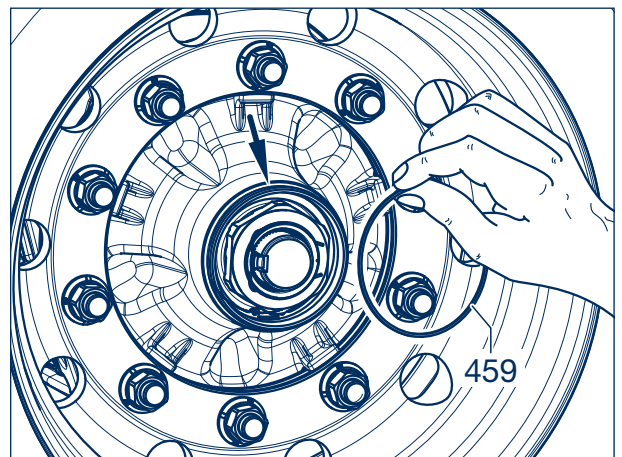

Figure 63

[71] Cover the hub cap (460) in the area of the O-ring contact surface (only with ECO Plus 3) and the thread with a thin coat of BPW special longlife grease **ECO-Li^{Plus}**.

[72] Screw the hub cap onto the wheel hub (460) and tighten it to the tightening torque.

Tightening torques:

ECO Plus 3 hub cap	AF 110	350 Nm
ECO Plus hub cap	AF 110	800 Nm



Warning!
The braking effect of new discs and linings is only at its optimum after a few braking operations.
For this reason, run in new brake linings while avoiding lengthy and unnecessarily sharp brake operations.

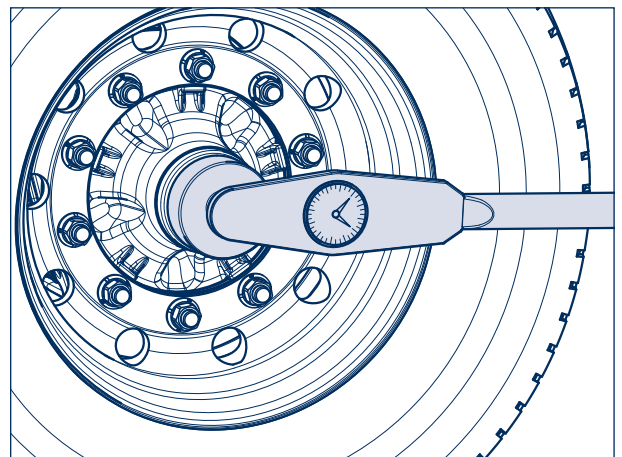

Figure 64

15 Dismantling and assembling the hub unit

15.1 ECO PLUS 3 UNIT



Note!

Opening the ECO Plus 3 Unit before the end of the warranty period invalidates the ECO Plus warranty (see ECO Plus warranty documents).

- [1] Disassembly and assembly of the complete ECO Plus 3 Unit (434), see chapter 14.1 and 14.2.
- [2] To remove the outer roller bearing (441), remove the locking ring (438) and the axle nut (446) from the wheel hub (435).

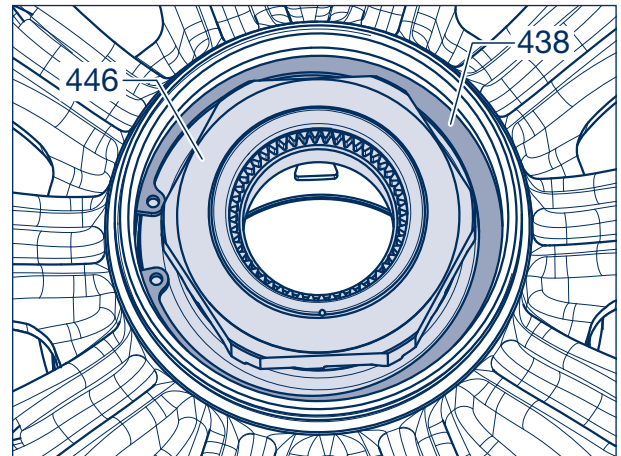

Figure 1

- [3] Remove the lug washer (445) and roller bearing (441).



Repair note!

Mark the hub and bearing so that they are not mixed up during assembly. It is essential for the bearing inner rings with rollers to be re-inserted in the same hubs.

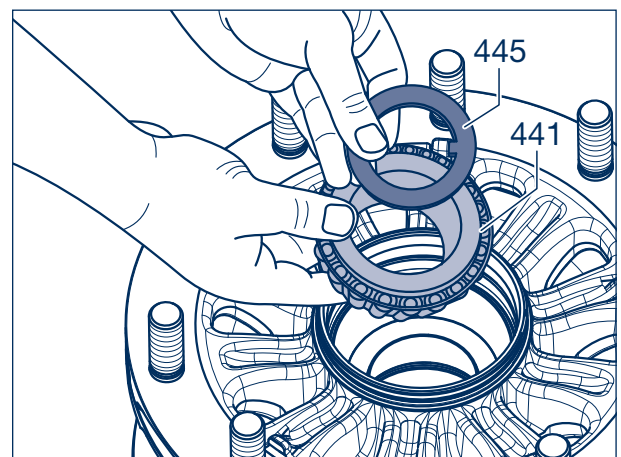

Figure 2

- [4] Lift up the exciter ring (560) from the wheel hub (435). In doing so, avoid damage to the base of the wheel hub.

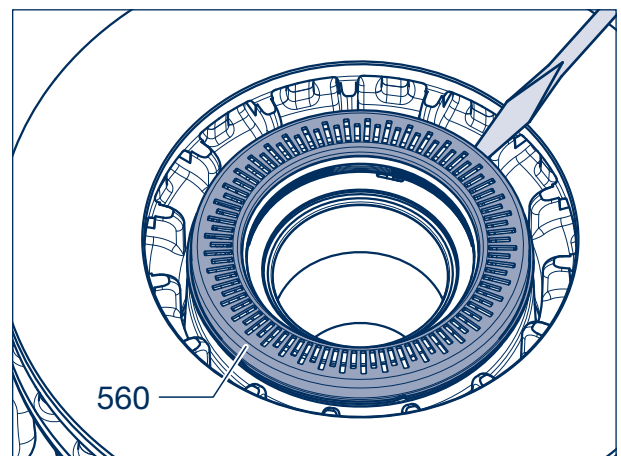

Figure 3

- [5] To remove the inner roller bearing (430), remove the locking ring (437) from the wheel hub (435).

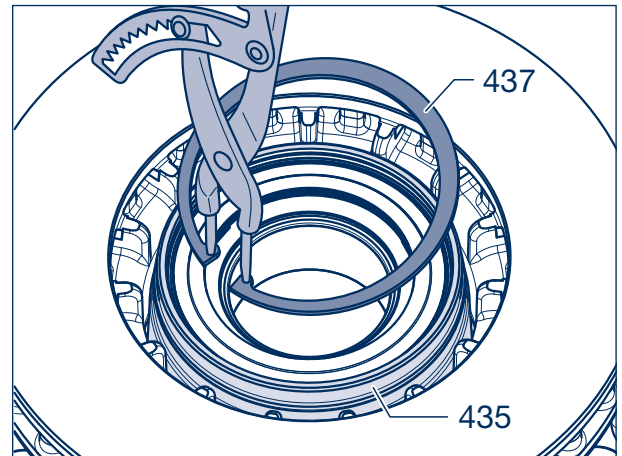

Figure 4

- [6] Release the radial lip seal (422) from the bearing race with a screwdriver.
[7] Remove the radial lip seal (422).

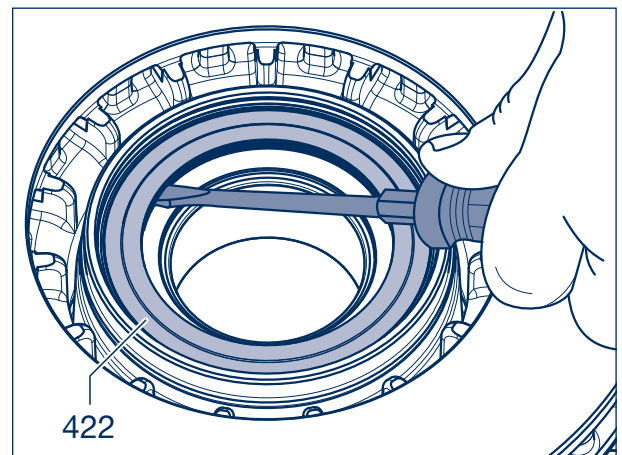

Figure 5

10 - 12 t ECO Plus 3

Remove the thrust washer (421) with radial lip seal (422) and O-ring (424).

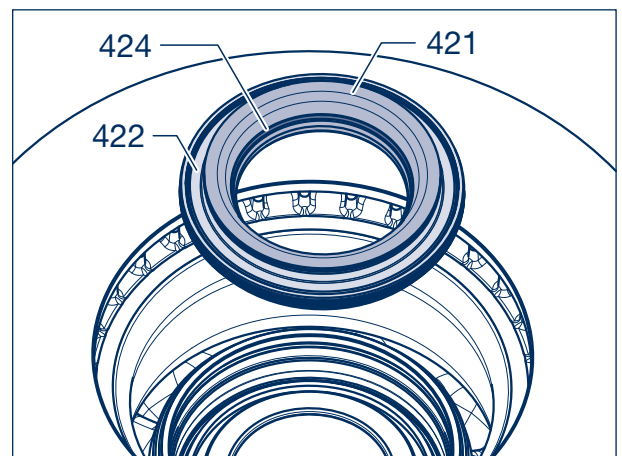

Figure 6

15 Dismantling and assembling the hub unit

- [8] Remove the inner roller bearing (430).
- [9] Remove both roller bearings, clean thoroughly and check for wear. Replace them if necessary.

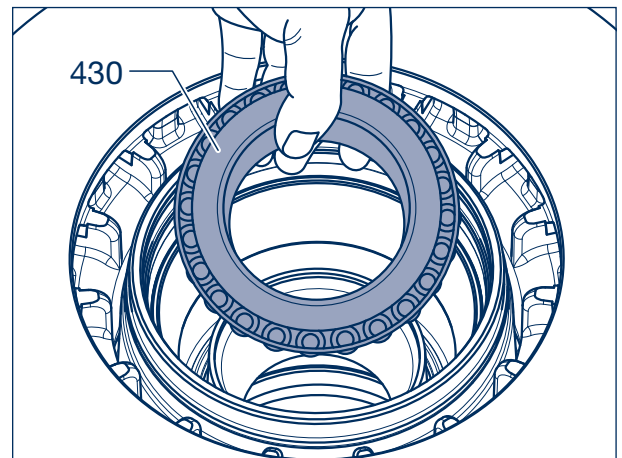

Figure 7



Note!
If the bearing cups have to be replaced, it is recommended to dismantle the brake disc.

- [10] Drive the wheel studs (472) out of the removed hub/brake disc unit (do not damage the threads of the wheel studs).

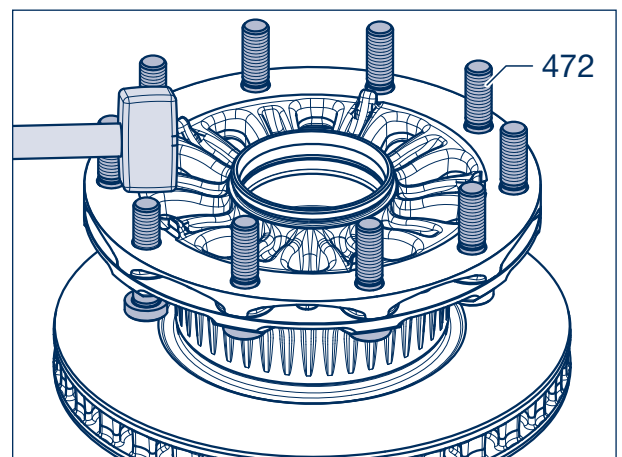

Figure 8

- [11] Lever the grease cartridge (432) out of the bearing cavity.

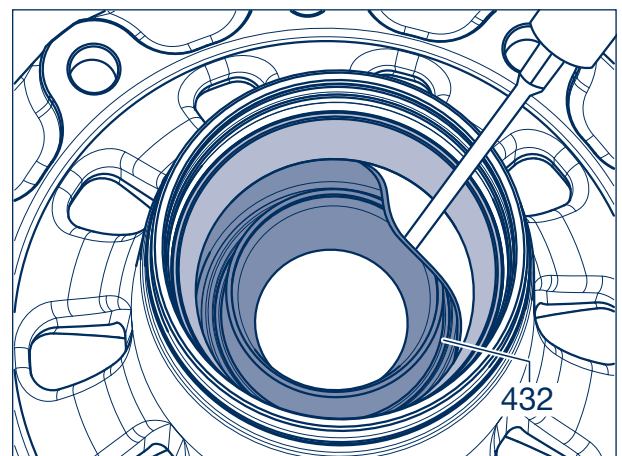

Figure 9

- [12] Take the grease cartridge (432) out of the wheel hub (435).

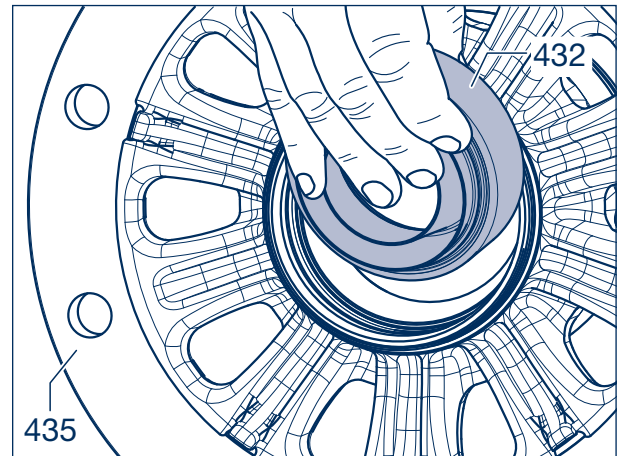

Figure 10

- [13] Drive the bearing outer rings out of the wheel hub (435).

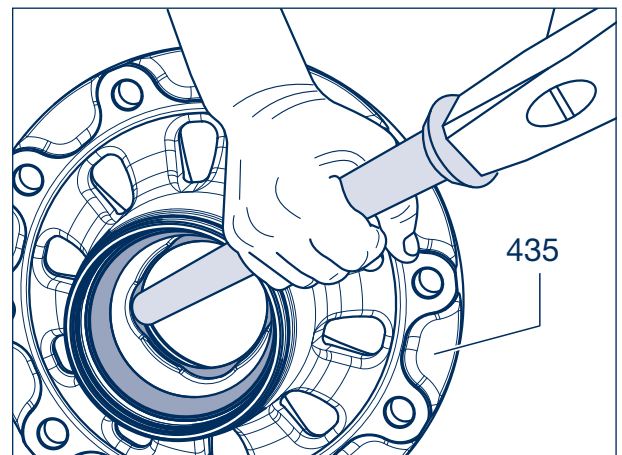

Figure 11

- [14] Centre the new bearing outer rings and insert them in the wheel hub. Install using a press (min. 6 t) and the BPW insertion tools 15.011.20052 and 15.013.20052.



Note!
Make sure the bearing cups are correctly seated in the wheel hub.

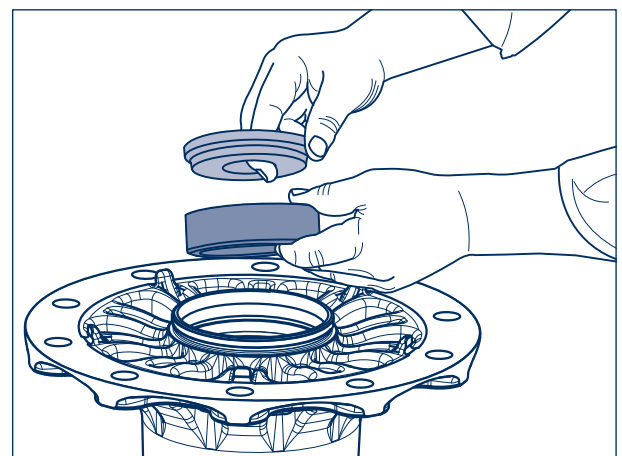

Figure 12

15 Dismantling and assembling the hub unit

- [15] Insert the seal (432/bearing intermediate piece) between the installed bearing outer rings.

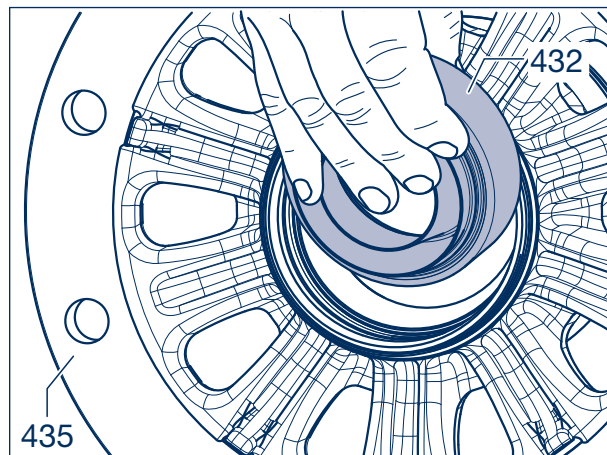

Figure 13

- [16] Grease both roller bearings with BPW special longlife grease ECO-Li^{Plus}. Note the total grease quantity (roller bearings 33318 - 170 g and 33213 - 120 g).



Note!
We recommend lubricating the bearings with BPW grease sprays 99.00.000.9.55.

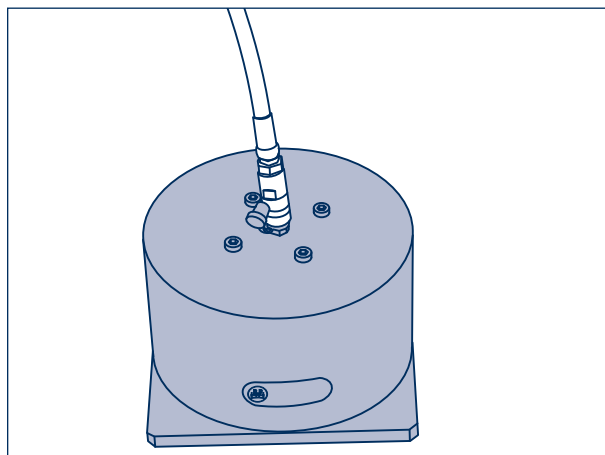

Figure 14

- [17] Insert the inner roller bearing (430) into the wheel hub (435).



Repair note!
Do not mix up the bearing cages and outer bearing rings.

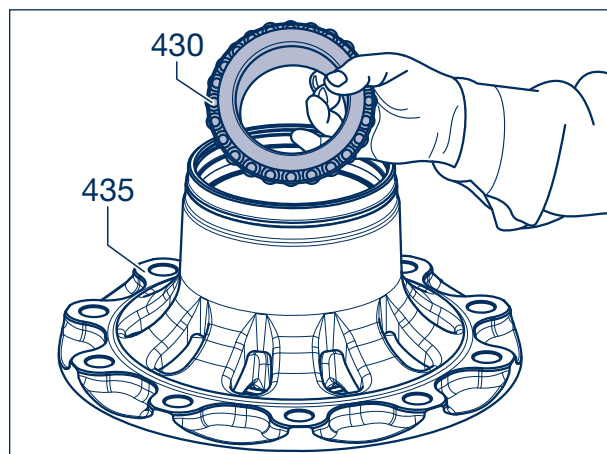

Figure 15

10 - 12 t ECO Plus 3

- [18] Press in the new oil seal (422) up to the stop against the thrust washer (421).

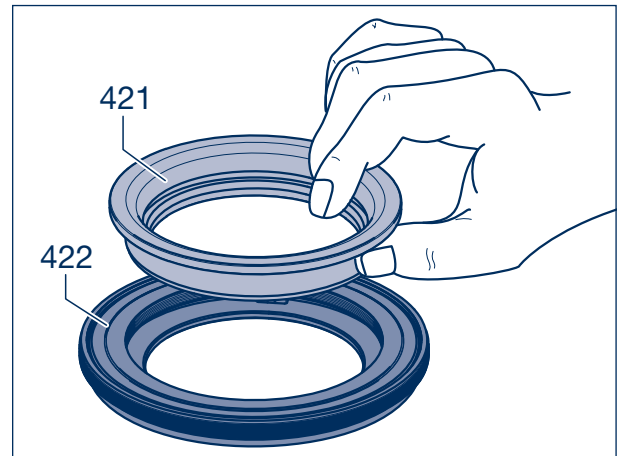

Figure 16

- [19] Insert the O-ring (424) into the groove of the thrust washer (421).

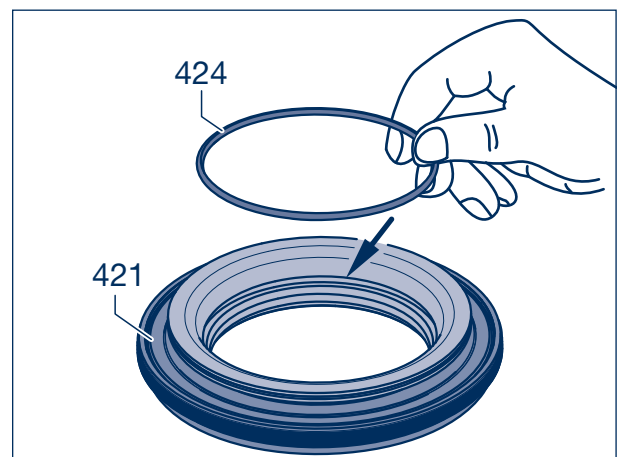

Figure 17

8 - 9 t ECO Plus 3

- [20] Insert the lip seal (422) into the wheel hub (435) with the 3 locating tangs facing the bearing (430).

10 - 12 t ECO Plus 3

- [20] Insert the thrust washer (421) with oil seal (422) and O-ring (424) into the wheel hub (435).

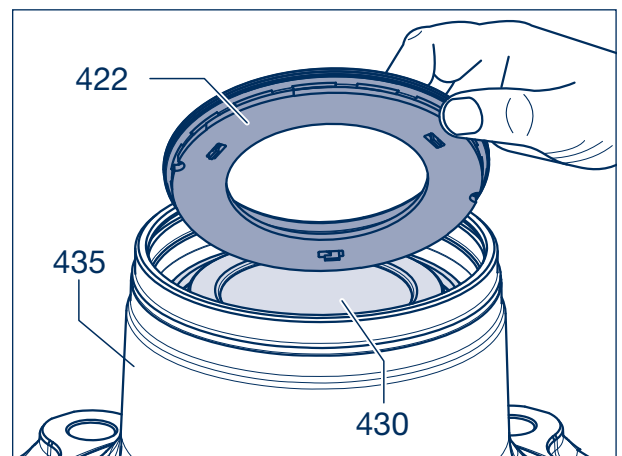

Figure 18

15 Dismantling and assembling the hub unit

- [21] Place the hub cap (460) onto the seal (422) and tap it in with light hammer blows until the seal is in contact with the bearing.

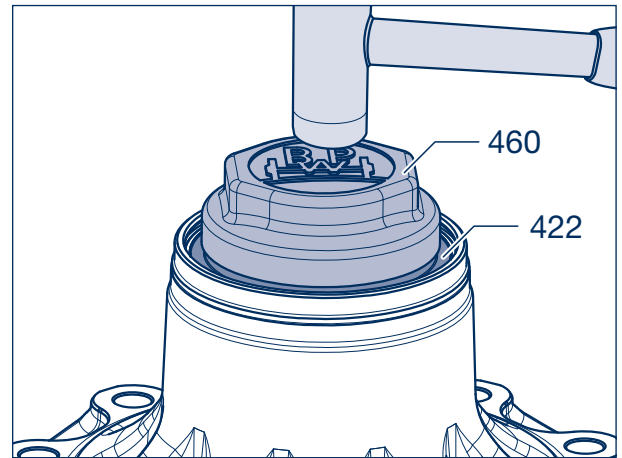

Figure 19

- [22] Fit the locking ring (437) into the groove of the wheel hub.

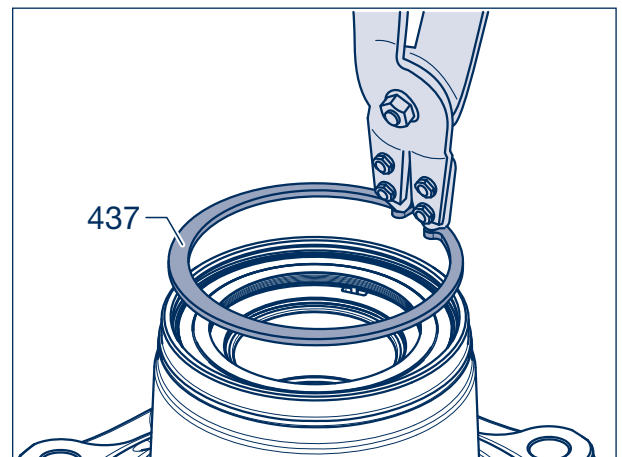

Figure 20

- [23] Clean the groove and stop surfaces for the exciter ring (560) (free from dirt, paint, etc.).

- [24] Fit the new exciter ring and fasten with the assembly tool (BPW No. 16.038.22953) until they make contact.

Wheel connection Wheel stud x Reference diameter Ø	Exciter ring Number of teeth	Bearing ECO Plus 3
10 x 335	90	8 - 9 t
8 x 275	90	8 - 9 t
Exciter rings with 80 and 100 teeth can be purchased as separate parts/spare parts for special applications.		
10 x 335	100	10 - 12 t
8 x 275	80	10 - 12 t

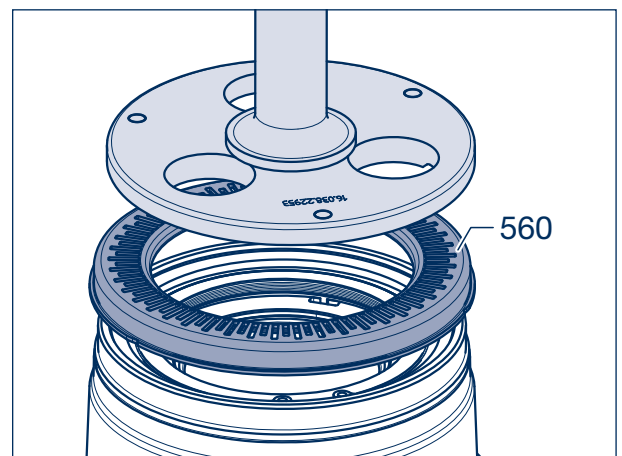

Figure 21

- [25] Lay the ECO Unit (434) on the new brake disc (380).
- [26] Align the bore holes for the wheel bolts (472) of the ECO Unit (434) and the brake disc (380).
- [27] Insert the wheel bolts (472) into the brake disc / ECO Unit as far as possible. Make sure the wheel bolt head is correctly placed on the brake disc (380) (torsion protection).
- [28] Tighten the wheel studs (472) crosswise using a ring (BPW no. 02.5683.92.00) and nut until they make contact with the brake disc (380).



Repair note!

The flattened side of the wheel stud (472) must rest against the brake disc collar (380).

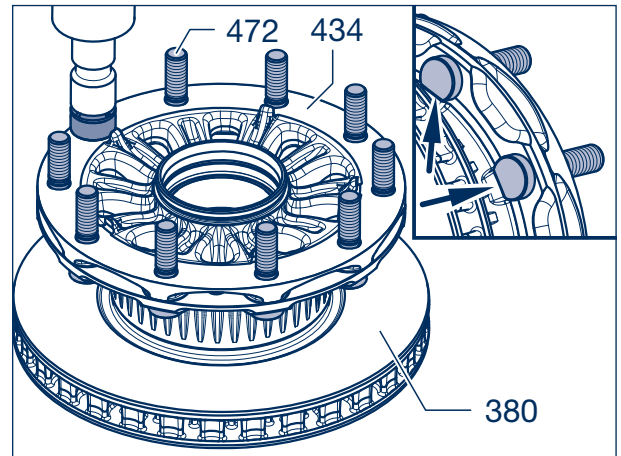

Figure 22

- [29] Insert the outer roller bearing (441) into the wheel hub (435).

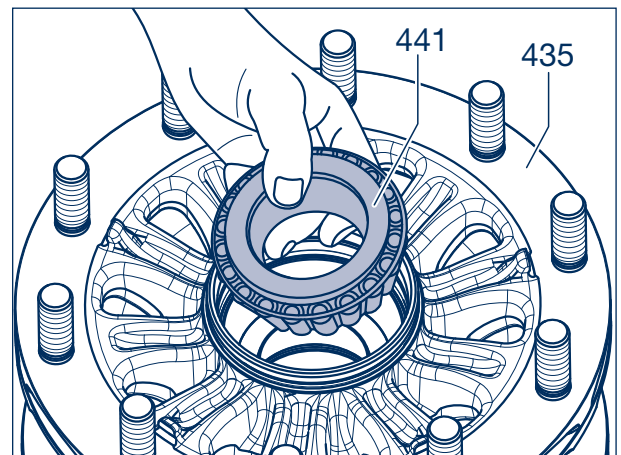

Figure 23

- [30] Place the lug washer (445) (with the embossed BPW and item number) next to the roller bearing (441).

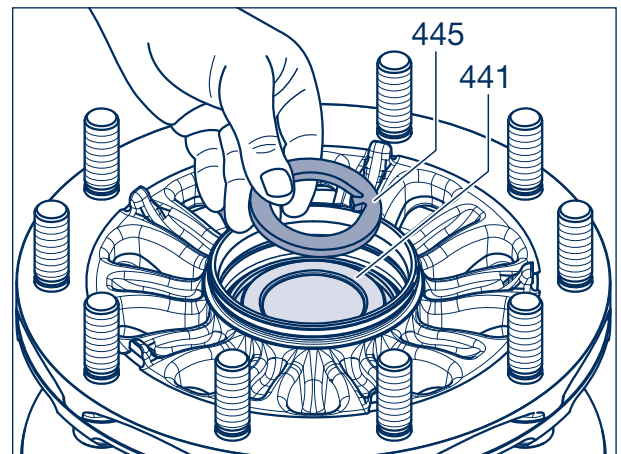

Figure 24

15 Dismantling and assembling the hub unit

- [31] Insert the locking ring (438) with axle nut (446) into the groove of the wheel hub (435).
Mounting the complete ECO Unit (434), see chapter 14.1 and 14.2.

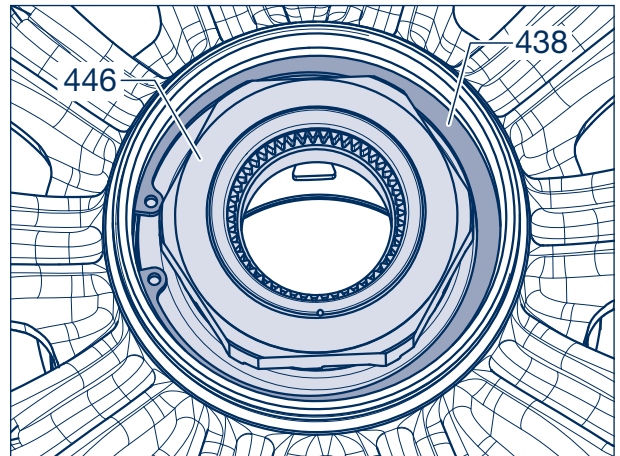

Figure 25

15.2 ECO^{Plus} UNIT



Note!
Opening the ECO^{Plus} Unit before the end of the warranty period invalidates the ECO Plus warranty (see ECO Plus warranty documents).

- [1] Disassembly and assembly of the complete ECO^{Plus} Unit (434), see chapter 14.1 and 14.2.
- [2] To remove the outer roller bearing (441), remove the locking ring (438) and the axle nut (446) from the wheel hub (435).

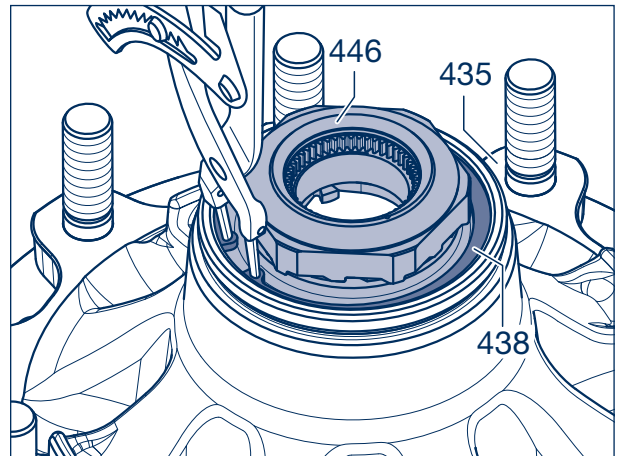

Figure 26

- [3] Remove the lug washer (445) and roller bearing (441).



Repair note!
Mark the hub and bearing so that they are not mixed up during assembly. It is essential for the bearing inner rings with rollers to be re-inserted in the same hubs.

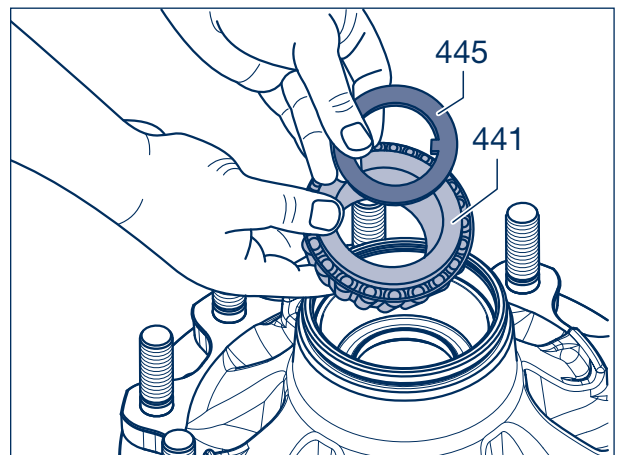

Figure 27

Exciter ring clamped

- [4] Gently pull on the clamps at the outer edge of the exciter ring (560) and remove the exciter ring from seat of the wheel hub.



Repair note!
Do not deform or damage the exciter ring (560) when removing it.

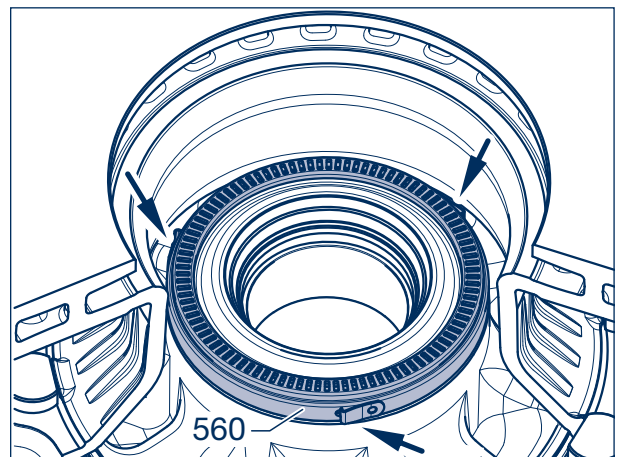

Figure 28

15 Dismantling and assembling the hub unit

Exciter ring screwed on

- [4] Unscrew the cylinder head screws M 6 (561, AF 5) with spring washers (563) from the brake disc (380) / exciter ring (560) and remove the exciter ring.

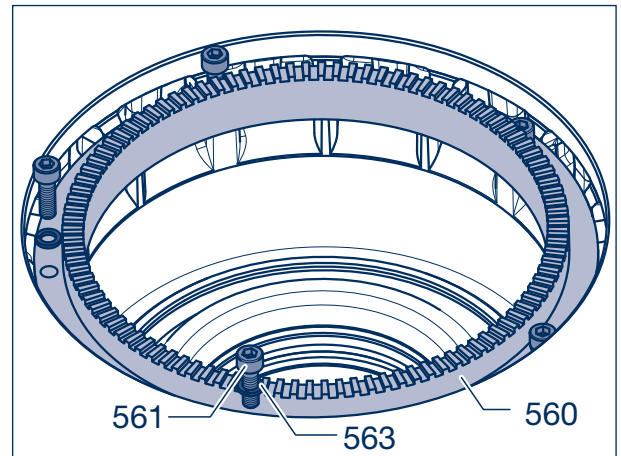

Figure 29

- [5] To remove the inner roller bearing (430), remove the locking ring (437) from the wheel hub (435).

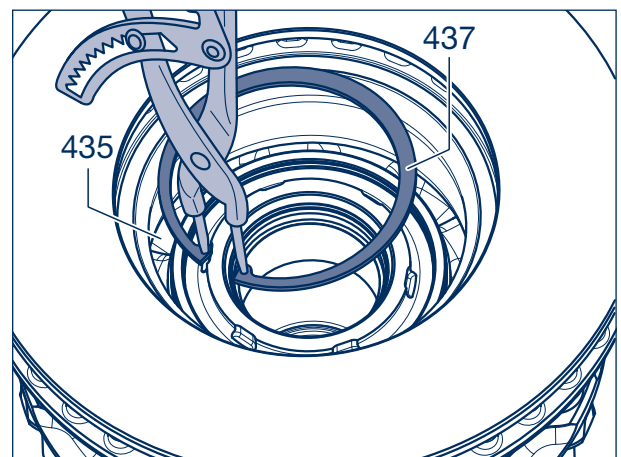

Figure 30

- [6] Remove the thrust washer (421) with oil seal (422) and O-ring (424).

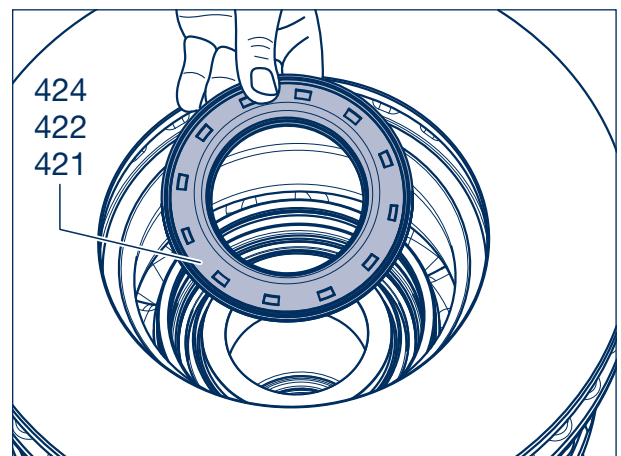

Figure 31

- [7] Remove the inner roller bearing (430) and then the seal (432/ bearing intermediate piece).
- [8] Clean both roller bearings thoroughly and check them for wear. Replace them if necessary.

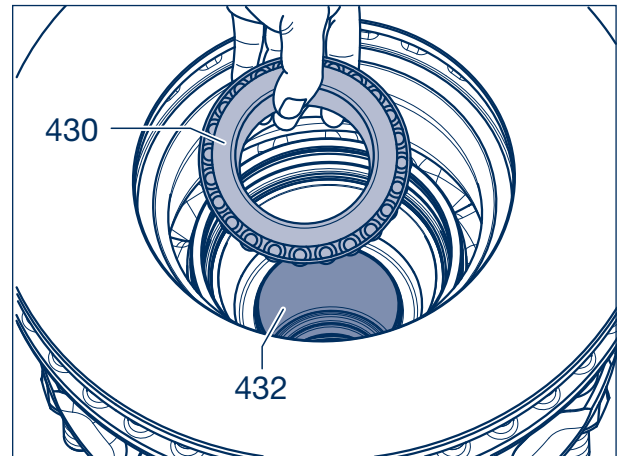

Figure 32



Note!
The brake disc should be removed if the bearing cups have to be replaced for the TS2 3709 with ET 0.

- [9] Drive out the wheel studs (472) from the dismantled hub brake disc unit (do not damage the thread of the wheel studs).

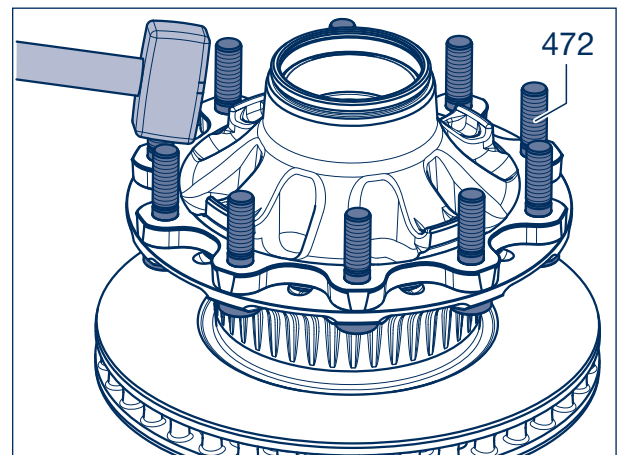

Figure 33

- [10] Drive out the bearing outer rings from the wheel hub (435).
- [11] Remove the dust cover (431) from the wheel hub.

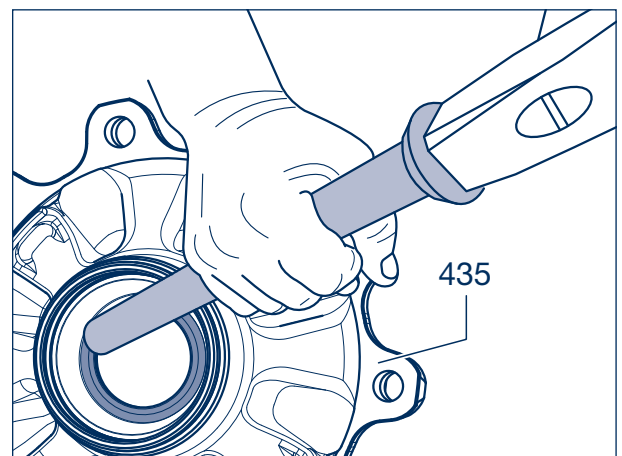

Figure 34

15 Dismantling and assembling the hub unit

- [12] Fit the thrust washer (440) with the curved side facing the hub (435).

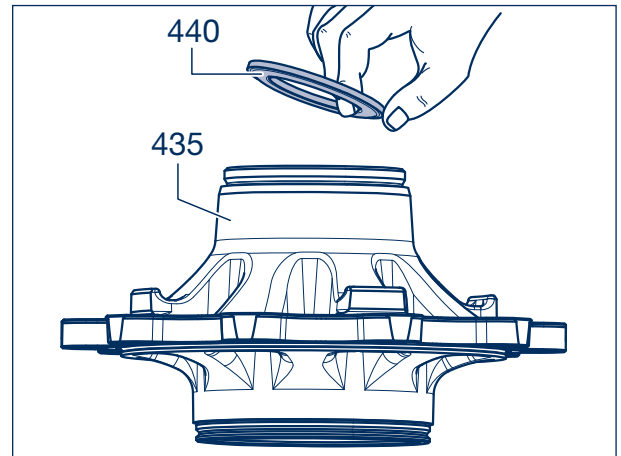

Figure 35

- [13] Insert a new dust cover (431).
- [14] Centre the bearing outer rings and insert them in the wheel hub (435). Install using a press (min. 6 t) and the BPW insertion tools 15.011.20052 and 15.013.20052.



Note!
Make sure the bearing cups are correctly seated in the wheel hub.

- [15] Insert the seal (432/bearing intermediate piece) between the installed bearing outer rings.

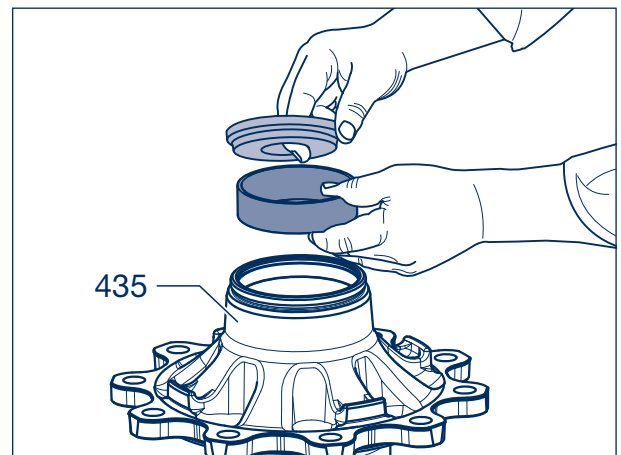

Figure 36

- [16] Grease both roller bearings with BPW special longlife grease ECO-Li^{Plus}. Note the total grease quantity (roller bearings 33318 - 170 g and 33213 - 120 g).



Note!
We recommend lubricating the bearings with BPW grease sprays 99.00.000.9.55.

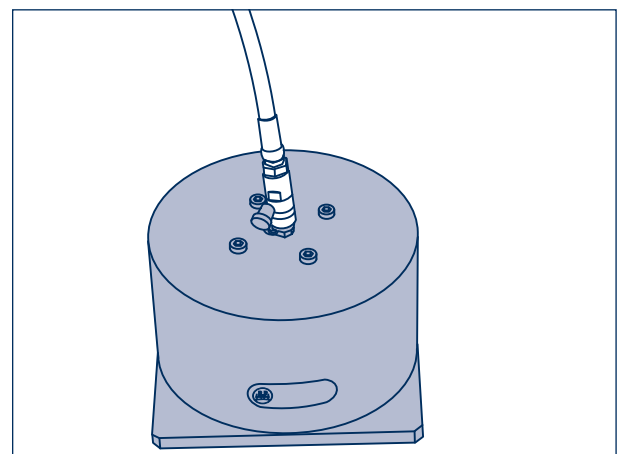

Figure 37

- [17] Insert the inner roller bearing (430) into the wheel hub (435).

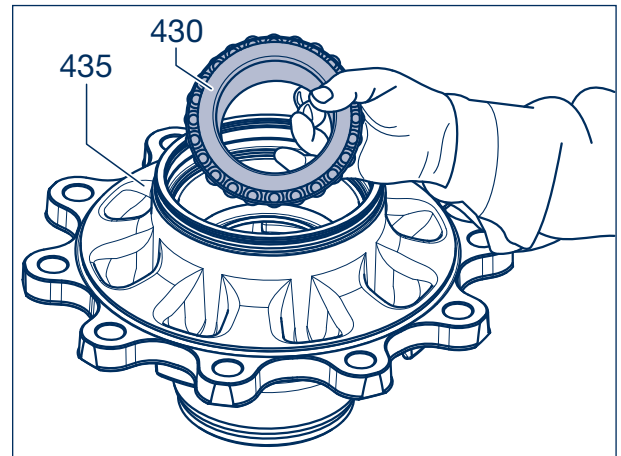

Figure 38

- [18] Press in the new oil seal (422) up to the stop against the thrust washer (421).

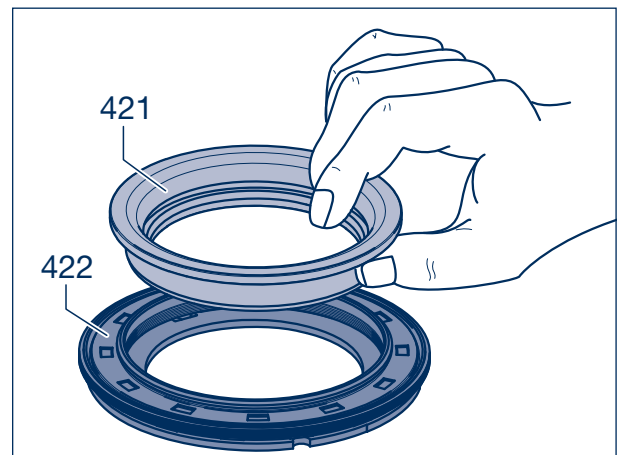

Figure 39

- [19] Insert the O-ring (424) into the groove of the thrust washer (421).

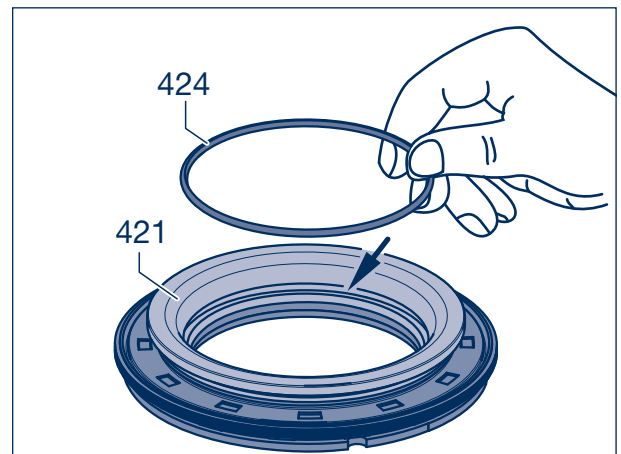

Figure 40

15 Dismantling and assembling the hub unit

- [20] Insert the thrust washer (421) with oil seal (422) and O-ring (424) into the wheel hub (435).

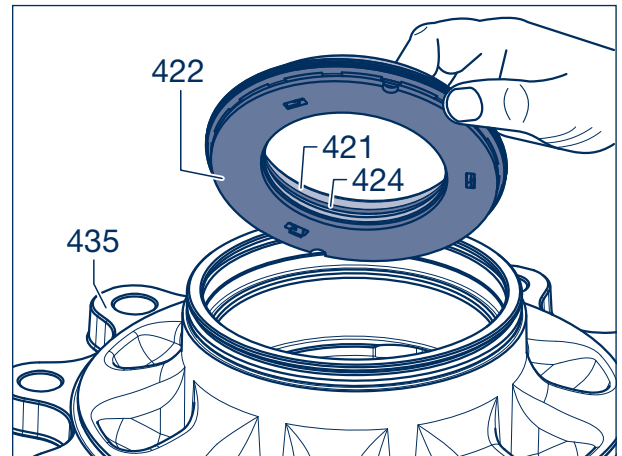

Figure 41

- [21] Place the hub cap onto the seal and tap it in with light hammer blows until the seal is in contact with the bearing.

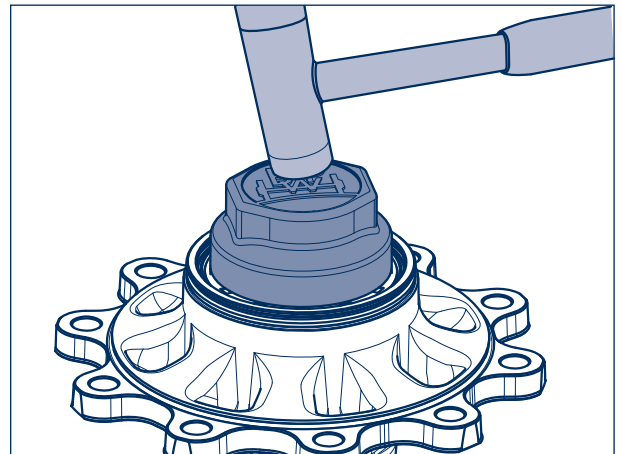

Figure 42

- [22] Insert the locking ring (437) into the groove of the wheel hub.

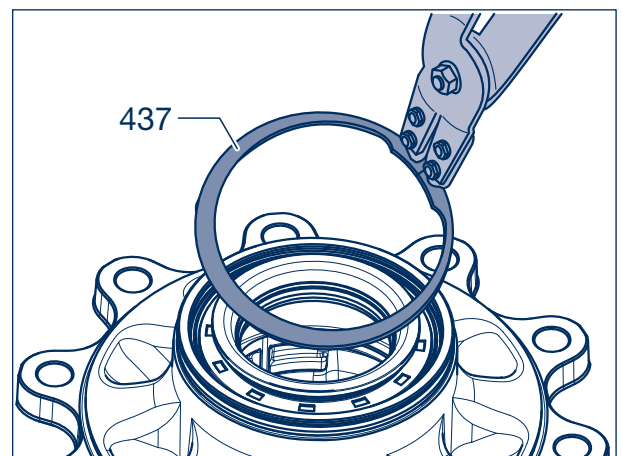

Figure 43

- [23] Lay a new brake disc on the wheel hub.
- [24] Align the bore holes for the wheel bolts of the ECO Unit and the brake disc.
- [25] Insert the wheel bolts into the brake disc / ECO Unit as far as possible. Make sure the wheel stud head is correctly seated on the brake disc (torsion protection).
- [26] Tighten the wheels studs crosswise using a ring (BPW no. 02.5683.92.00) and nut until they come into contact with the brake disc.



Repair note!

The flattened side of the wheel stud (472) must rest against the brake disc collar (380).



Repair note!

If there is insufficient preload to ensure a tight seat of the exciter ring, the exciter ring must be replaced.

- [27] Clean the groove and contact surfaces for the exciter ring (560) (free from dirt, paint, etc.).

Exciter ring clamped

- [28] Press the new exciter ring (560) onto the wheel hub (435), turning slightly anticlockwise.
- [29] The lateral clamps must clip into the groove on the neck of the wheel hub.

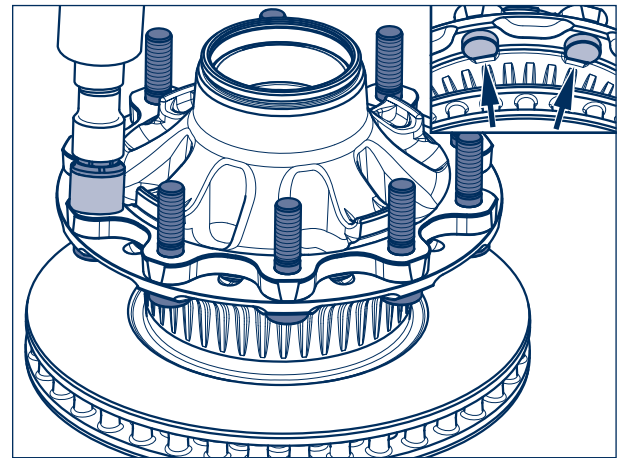

Figure 44

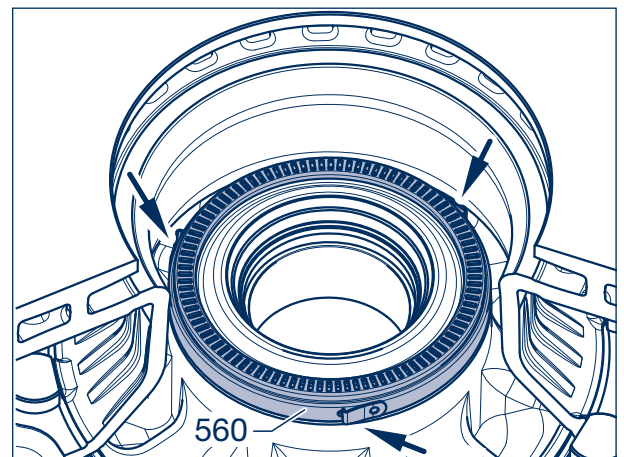

Figure 45

Exciter ring screwed on

- [28] Insert a new exciter ring (560) into the brake disc (380).
- [29] Screw the exciter ring with 5 cylinder head screws M 6 (561, AF 5) and spring washers (563) to the brake disc.

Tightening torque: 8 Nm

Wheel connection Wheel stud x Reference diameter Ø	Exciter ring Number of teeth
10 x 335	100
8 x 275	80

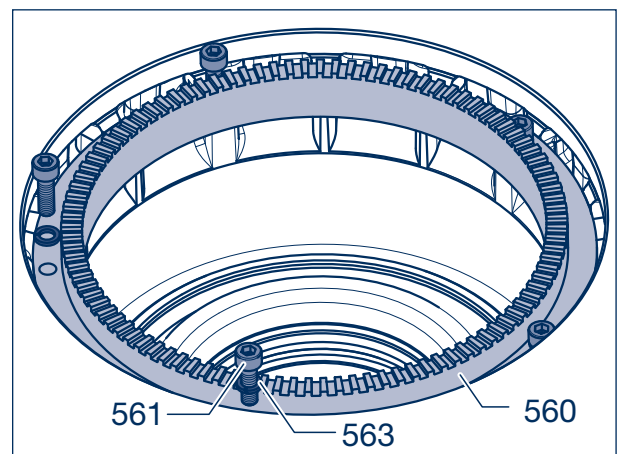

Figure 46

15 Dismantling and assembling the hub unit

- [30] Insert the outer roller bearing (441) into the wheel hub (435).

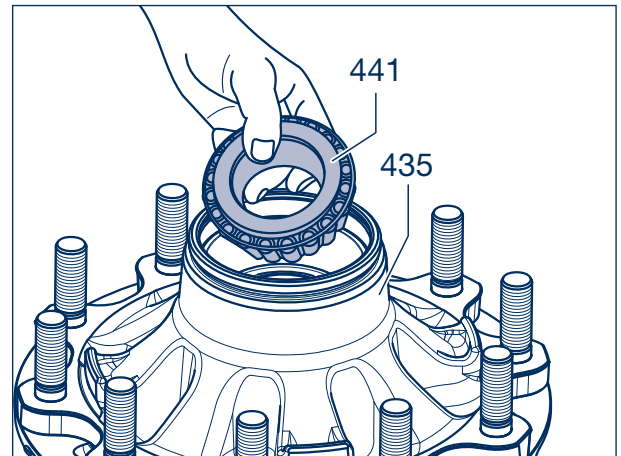

Figure 47

- [31] Place the lug washer (445) (with the embossed BPW and item number) next to the roller bearing (441).

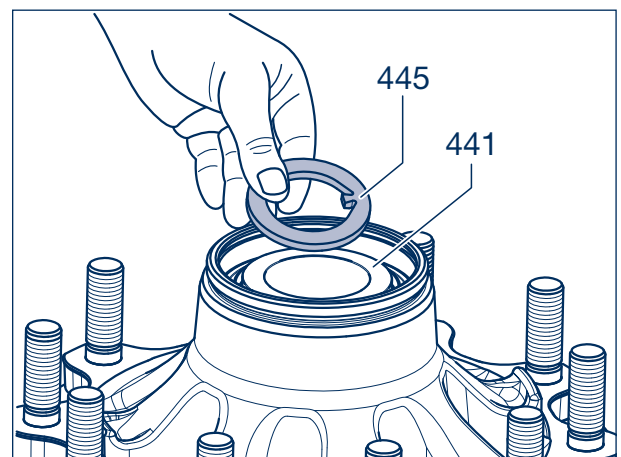

Figure 48

- [32] Insert the locking ring (438) with axle nut (446) into the groove of the wheel hub (435). Mounting the complete ECO Unit (434), see chapter 14.1 and 14.2.

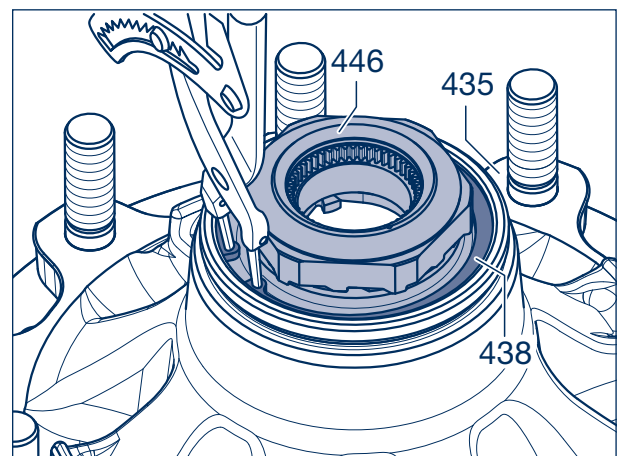
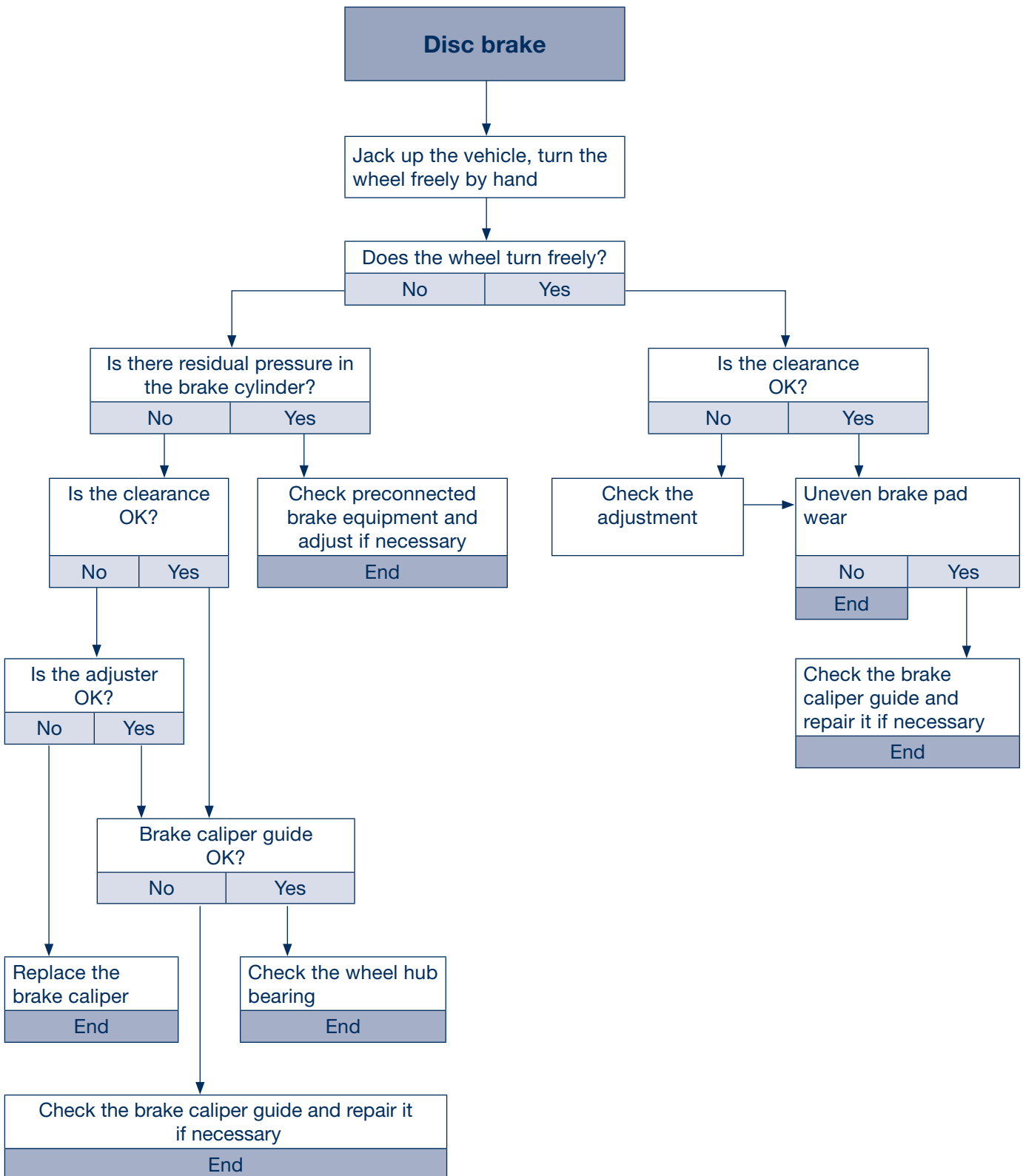

Figure 49

Troubleshooting 16



BPW is a globally leading manufacturer of intelligent running gear systems for trailers and semi-trailers. As an international mobility and system partner, we offer a wide range of solutions for the transport industry from a single source, from axle to suspension and brake to user-friendly telematics applications.

We thereby ensure outstanding transparency in loading and transport processes and facilitate efficient fleet management. Today, the well-established brand represents an international corporation with a wide product and service portfolio for the commercial vehicle industry. Offering running gear systems, telematics, lighting systems, composite solutions and trailer superstructures, BPW is the right system partner for automotive manufacturers.

BPW, the owner-operated company, consistently pursues one target: To always give you exactly the solution which will pay off. To this end, we focus our attention on uncompromising quality for high reliability and service life, weight and time-saving concepts for low operating and maintenance costs as well as personal customer service and a close-knit service network for quick and direct support. You can be sure that with your international mobility partner BPW, you always use the most efficient method.

Your partner on the economically viable path!



BPW Bergische Achsen Kommanditgesellschaft

Postbox 12 80 · 51656 Wiehl, Germany · Phone +49 (0) 2262 78-0
info@bpw.de · www.bpw.de