

Workshop Service – TS2 Disc Caliper

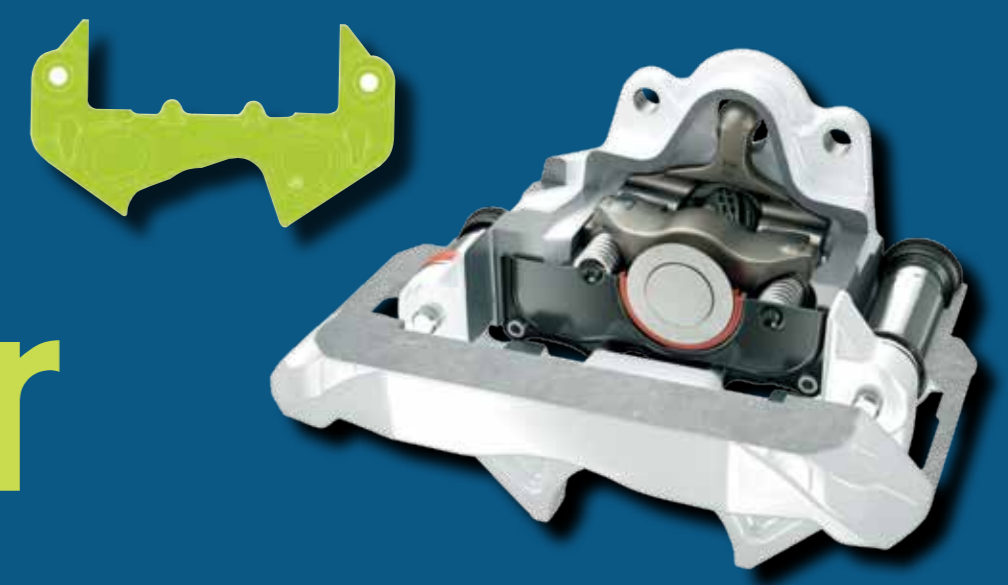

BRAKE ADJUSTMENT

1. Remove the plug.
2. Using a 13mm AF spanner turn the adjuster **CLOCKWISE** until a binding brake is achieved.
3. To set the running clearance, turn the adjuster using a 13mm AF spanner **ANTI-CLOCKWISE** by 90°.
4. Check brake is running freely.
5. Refit rubber plug ensuring the 'O' ring is seated correctly on the plug and the plug is seated correctly in the caliper. See Fig 1, 2 below.

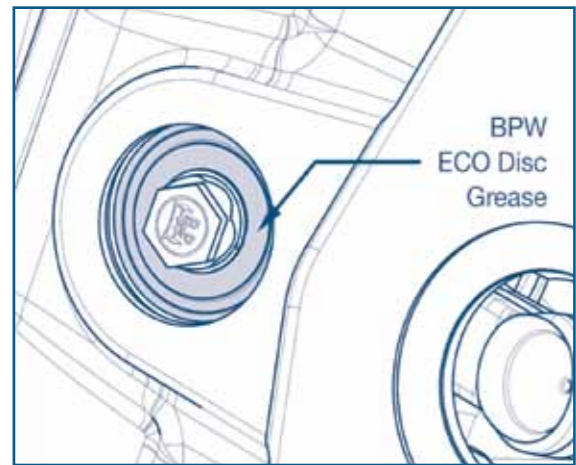

Fig 1

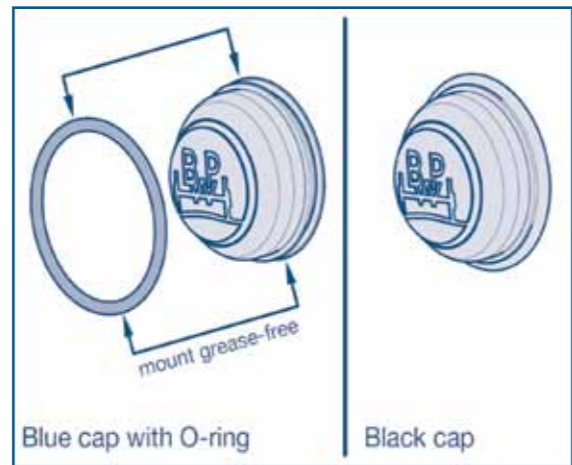
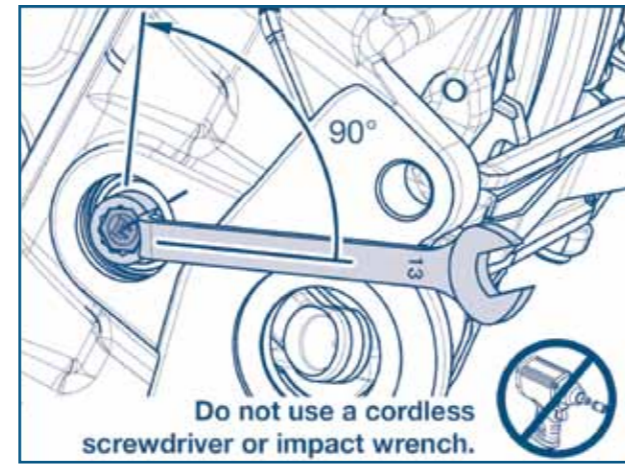

Fig 2



THREADED SCREW PLUG WITH O-RING

1. Ensure the O-ring is correctly seated on the collar of the sealing cap. See figure 3 below.
2. Screw the sealing cap (SW 21) with the O-ring into the brake calliper and tightening with a torque of 15Nm.

NOTE!

- The sealing cap with the O-ring is to be used without greasing, as there is a risk of overload due to excessive tightening torque.
- Ensure that the sealing caps are correctly seated to guarantee the sealing function.

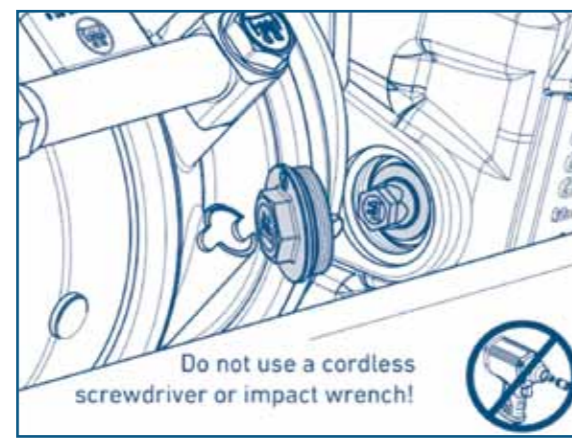
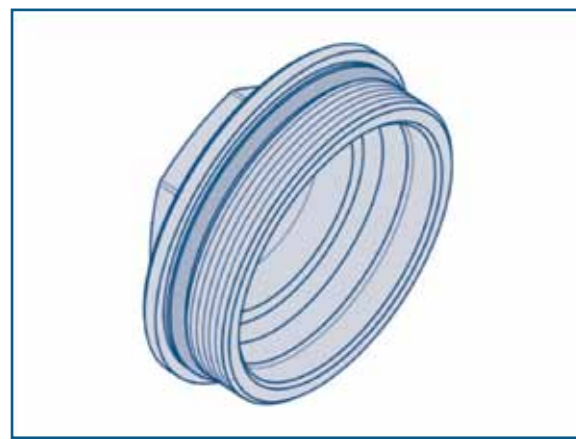

CHECK BRAKE CALIPER BEARING PLAY

INSPECTION – EVERY 6 MONTHS

The bearing play of the brake caliper guide pins can be checked using a dial gauge. Attach the dial gauge holder to the axle beam and position the gauge on the brake caliper housing on the brake cylinder holder (see figure 1).

Move the brake caliper from side to side radially from the centre of the axle (see the picture) and measure the total displacement. If the total amount measured on the gauge exceeds 1.0 mm, then the caliper guide pins and bushes must be replaced

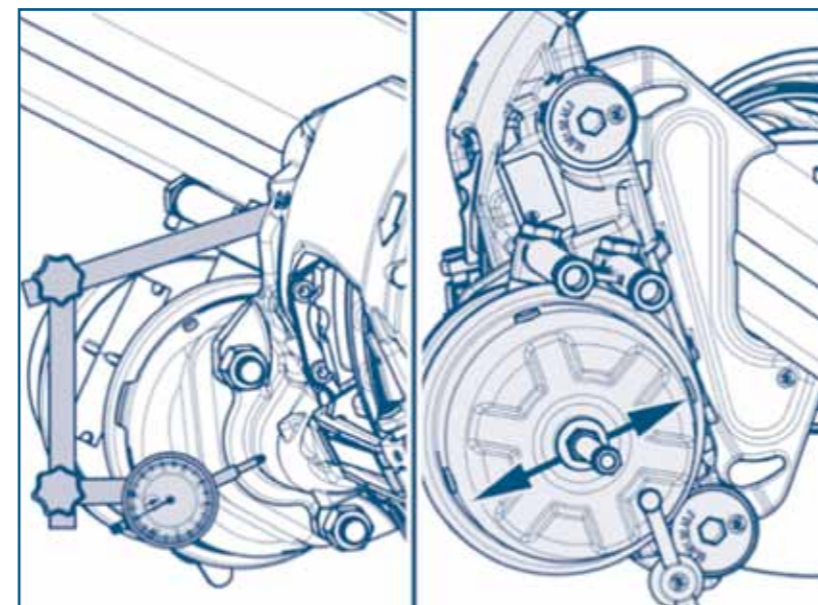

Fig 1

WEAR PLATES

When removing or replacing brake pads it is important to follow the instruction below.

Remove both wear plates (389) from the brake anchor plate, clean the housing, and insert new wear plates.

The wear plates must be greased on the rear side with BPW ECO-Li Plus grease.

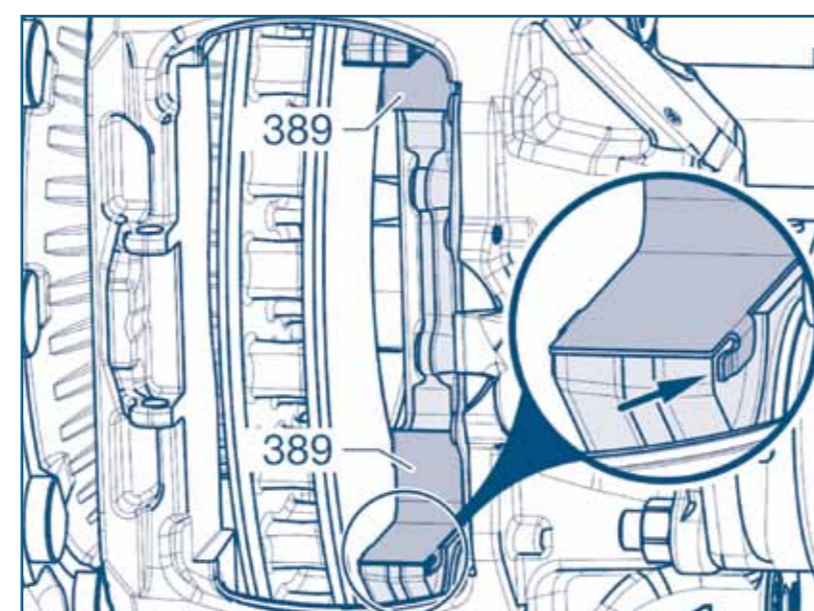

BRAKE PAD THICKNESS

The brake pad thickness must be checked every 3 months.

The thickness of the remaining pad must **NOT** be less than **2 mm**.

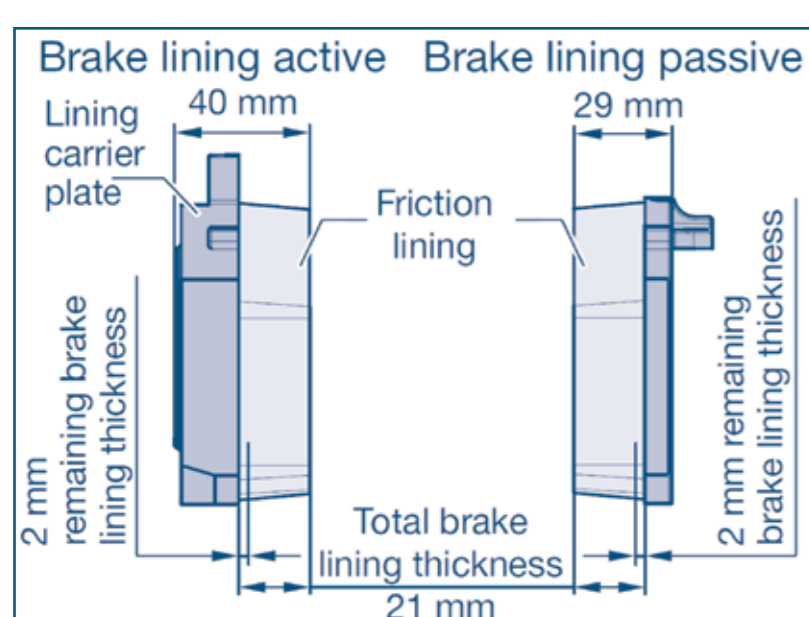

BRAKE DISC CONDITION

All new brake discs are 45 mm thick.

- Providing continuous cracks are not apparent, minimum brake disc thickness is 37 mm.
- Brake discs should be replaced in pairs. Brake pads should also be replaced when new brake discs are fitted.

If this instruction is not adhered to, there is a danger that braking performance could be seriously reduced.

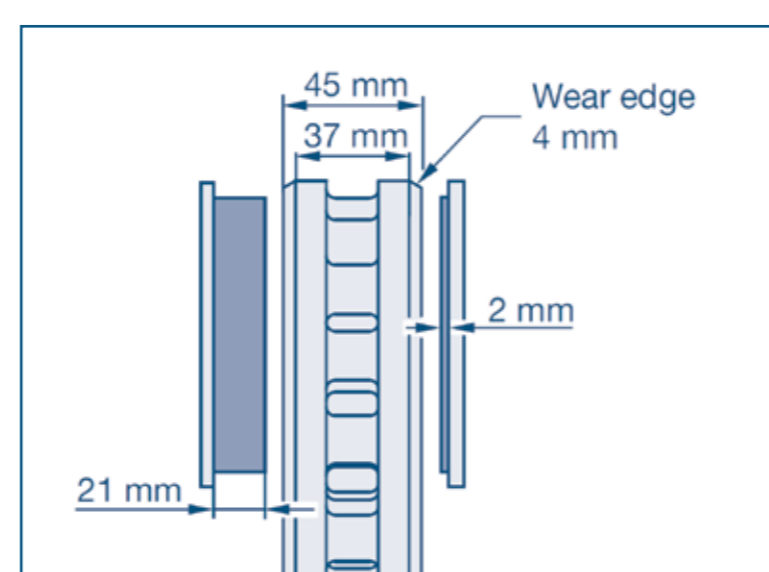

CHECK THE BELLOW WITH PRESSURE PLATES

INSPECTION – EVERY 6 MONTHS

- Prevent the vehicle from rolling away.
- Release the parking and service brakes.
- See workshop manual ECO Disc TS2 for information on how to remove the brake pads.
- The service brake and spring actuator must be released.
- Pull the pressure plate with heat protection cover and bellow out of the dust cover slightly.
- Check the complete unit for proper seating and damage; replace if it is necessary.
- Check the dust cover (see blue arrow) for deformation. If a deformation is detected, the brake caliper must be replaced.

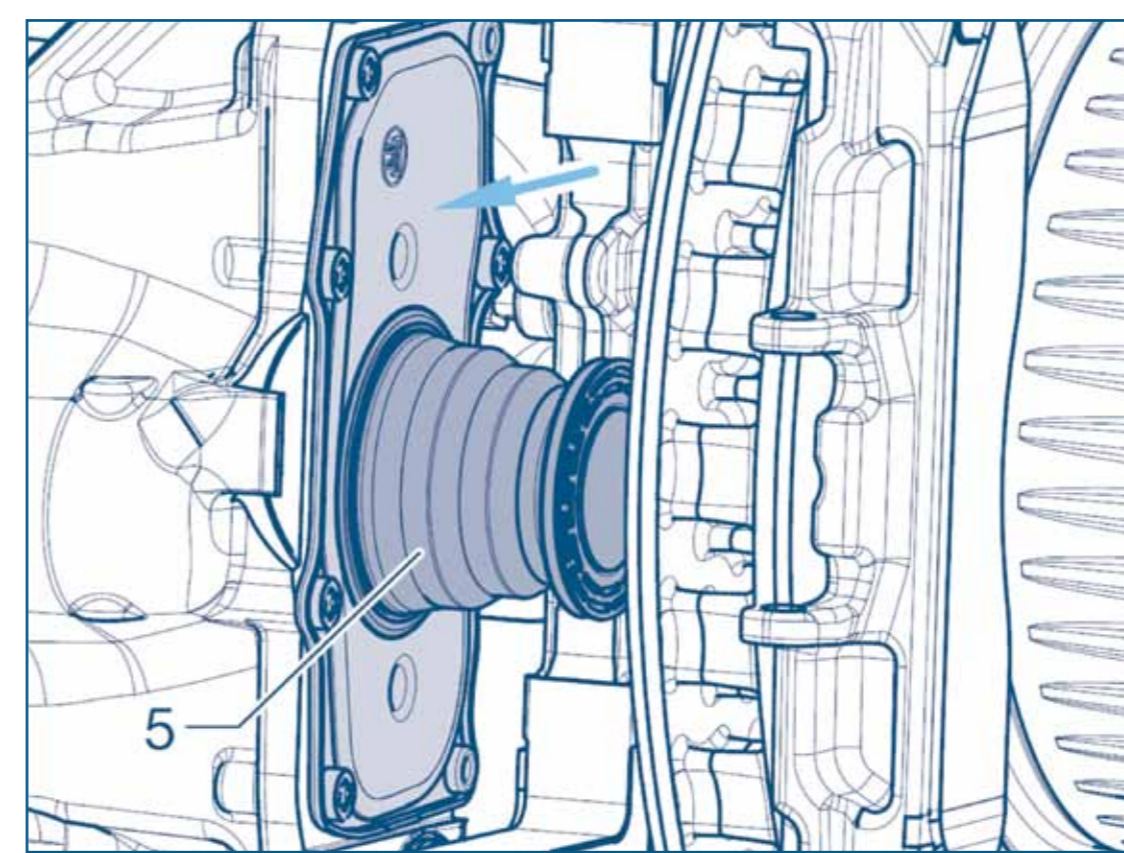

- If a thermal overloading of the brake has been detected, the bellow with pressure plate must be replaced.

Before the new bellow with pressure plate is installed, the adjusting unit must be checked for corrosion and ease of movement.

NOTE:

It is recommended that the pressure plate be replaced each time the brake disc is changed.

Refer to the workshop manual ECO Disc TS2 for details on changing the bellow with pressure pads.

NOTE:

The penetration of dirt and moisture causes corrosion and affects the operation of the clamping mechanism and adjustment.

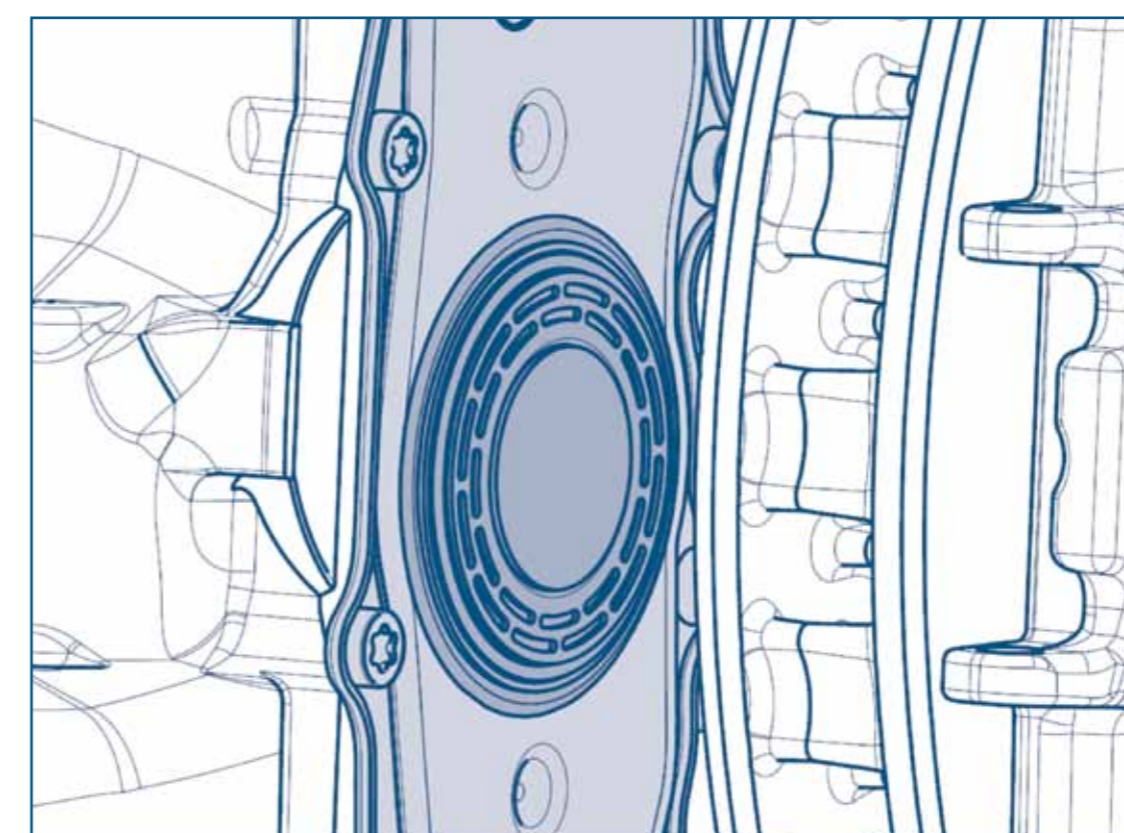

BRAKE PAD EDGE DEGRADATION

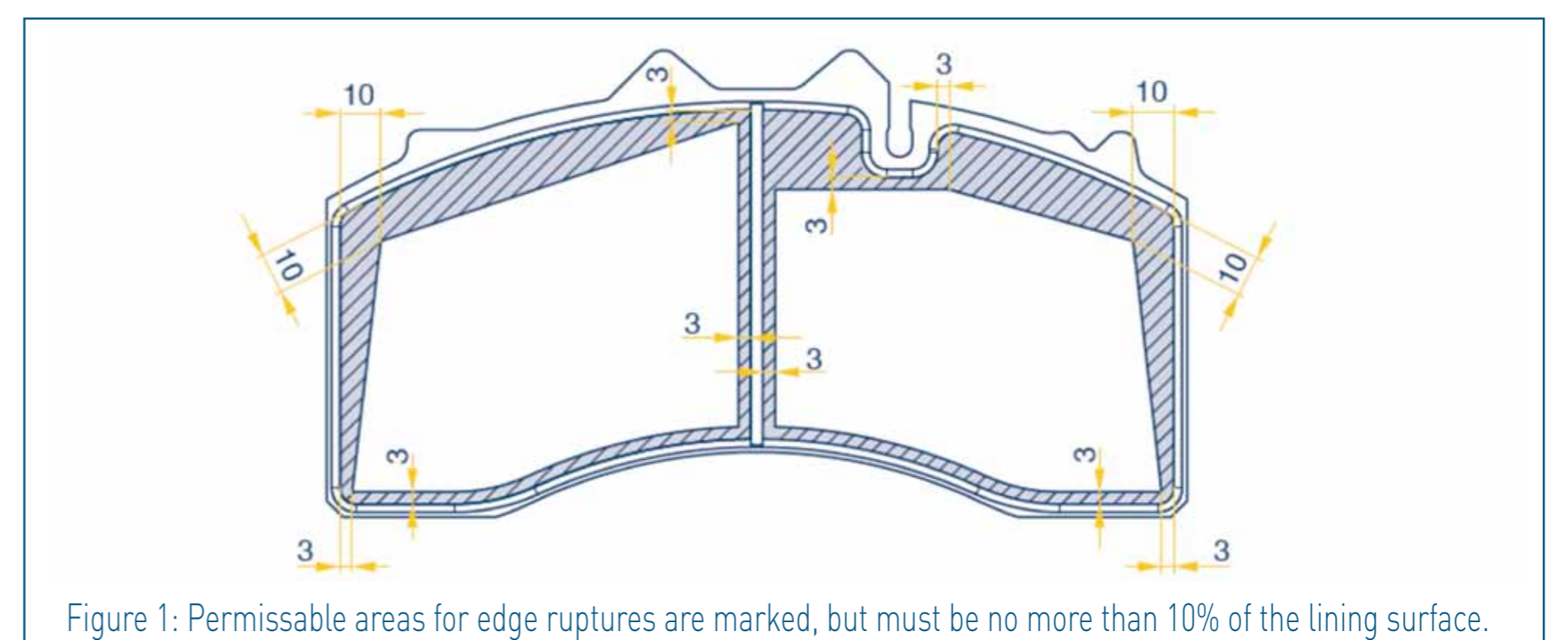

Figure 1: Permissible areas for edge ruptures are marked, but must be no more than 10% of the lining surface.

Some edge degradation on the brake pads is allowable, however the pads must be renewed if this exceeds the limits shown in the diagram (above) or accounts for more than 10% of the pad surface.

Edge degradation can be caused by the 'washing effect' that the front and lower edges of the brake pad are subject to during operation. Where this degradation is considered to be a problem, the effect can be minimised by the fitting of covers.



THE MINIMUM WEAR THICKNESS FOR THE BRAKE PAD IS 2 MM.

IMPORTANT: THE TS2 CALIPER IS NOT INTERCHANGEABLE WITH THE TSB CALIPER.

FOR MORE DETAILED INFORMATION PLEASE REFER TO THE BPW MAINTENANCE INSTRUCTION BOOK WHICH IS AVAILABLE TO DOWNLOAD: <https://www.bpw.co.za/support-service/support-downloads/workshop-manuals>